

Neo EP

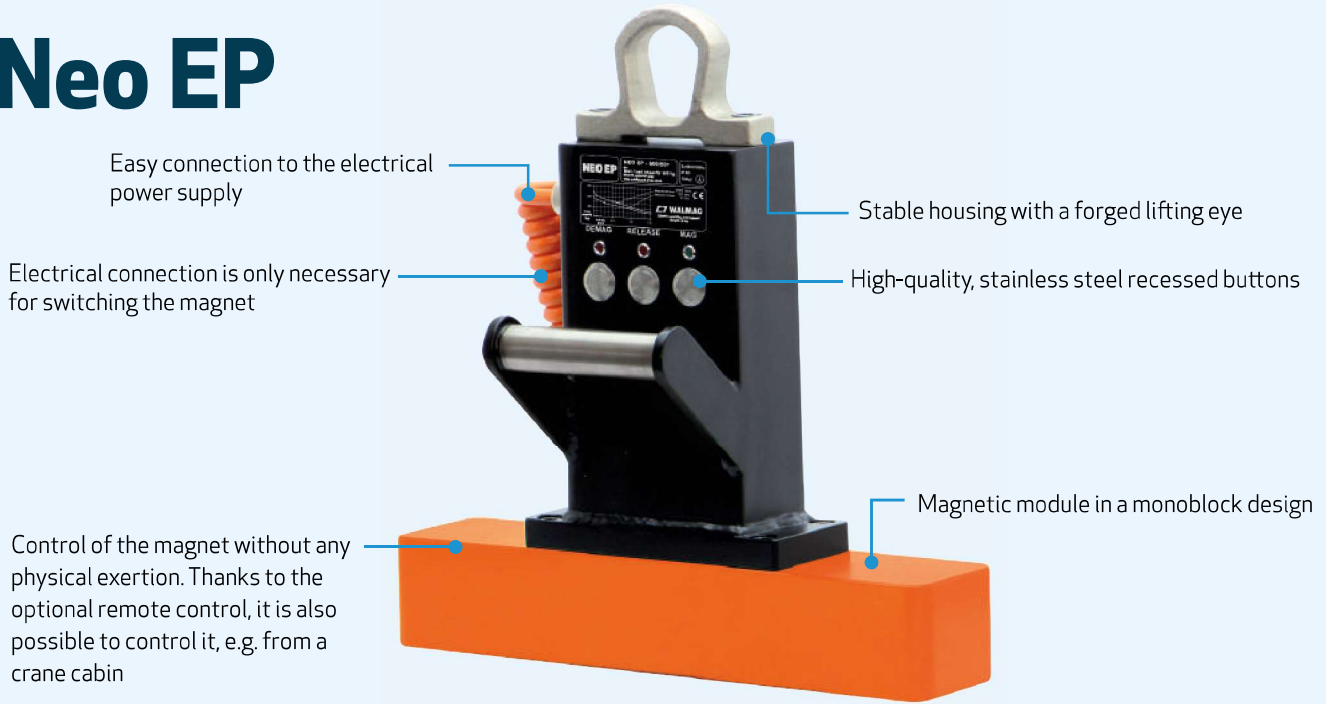

When to choose a Neo EP electropermanent lifting magnet:

Neo EP electropermanent lifting magnets are suitable for frequent and repeated workpiece handling and lifting – electrical control of the magnet requires no physical exertion, which is why it saves manpower and enhances work efficiency.

APPLICATION	TECHNOLOGY	LIFTING CAPACITY	ACTIVE MAGNETIC AREA	SAFETY FACTOR
 Lifting	 Electropermanent	 up to 4000 kg	 from 116 x 166 mm	 3:1

Important parameters:

Lifting capacity for flat material: up to 4000 kg
 Temperature: max. 80 °C
 Duty cyclus: 100 %

Use:

- NEOSQ300: handling smaller parts from mass production, blanks, forgings, castings
- NEOSQ600: handling longer parts and profiled sections
- NEOSQ1000: handling thicker sheets, burn parts, tools, and cuts
- NEOSQ4000: handling large parts during plasma cutting

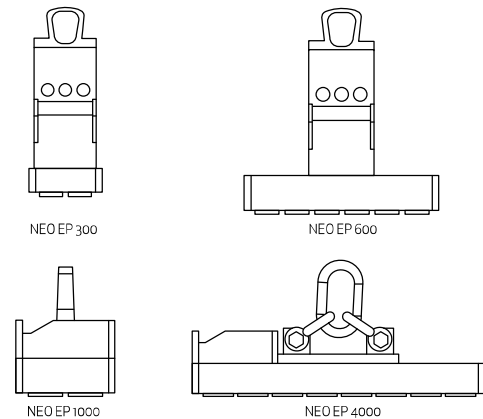

Model	W (mm)	L (mm)	H (mm)	Number of poles	Pole structure	Breakaway force (kN)	Clamping surface (mm)	Weight (kg)
NEOSQ300	164	164	420	4	50	14	116 x 166	23
NEOSQ600	95	420	450	6	50+	22	372 x 52	44
NEOSQ1000	228	228	295	4	80	36	172 x 172	77
NEOSQ4000	228	783	295	16	80	144	724 x 172	132