

BJP

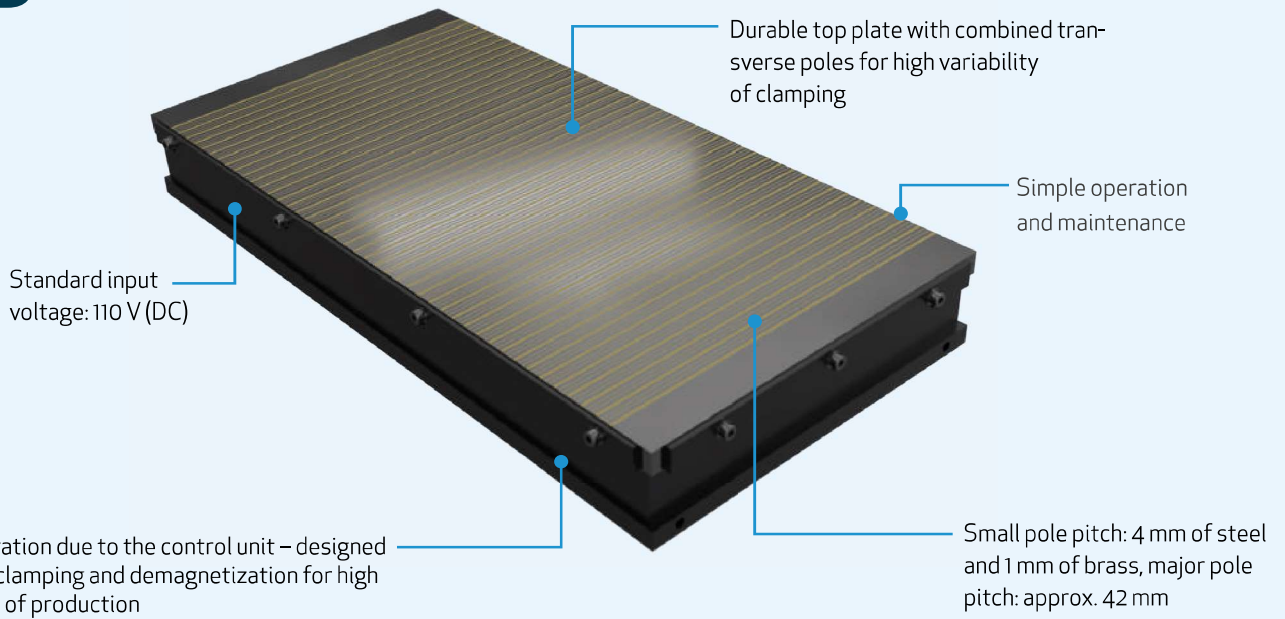

When to choose a BJP electromagnetic chuck:

The BJP electromagnetic chuck is suitable heavy duty grinding of a wide range of parts from a minimum size of 35 x 35 x 3 mm. Thanks to the combined pole pitch, it also clamps very large parts very well. The electromagnet is operated simply by pressing the button on the remote control of the control unit. This unit also provides variable adjustment of the force to create optimum conditions for clamping.

APPLICATION



Grinding

TECHNOLOGY



Electro

CHUCK DIMENSION



from 200 x 600 mm

HOLDING FORCE



130 N/cm²

POLES



Transverse

Important parameters:

Application:	Grinding
Technology:	Electro
Holding force:	130 N/cm ²
Min. workpiece size:	35 x 35 x 3 mm
Regriding limit:	7 mm
Pole pitch:	42 mm
	further refined 4+1 (steel/brass)

Use:

- + heavy duty grinding for a wide range of workpiece sizes

Model	W (mm)	L (mm)	H (mm)	Wattage (W)	Weight (kg)
BJP200600	200	600	98	160	77
BJP300600	300	600	98	215	118
BJP400800	400	800	100	350	212
BJP3001000	300	1000	103	350	201
BJP4001000	400	1000	103	435	269
BJP5001000	500	1000	108	530	352
BJP6001000	600	1000	113	620	420

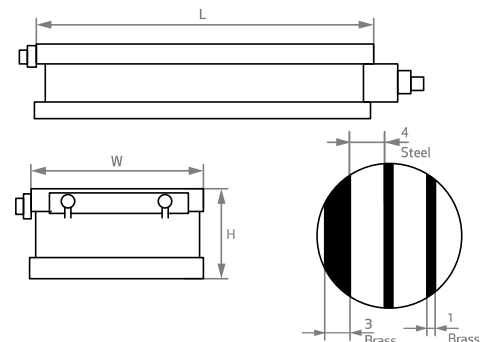

For more information, visit www.walmagmagnetics.com