

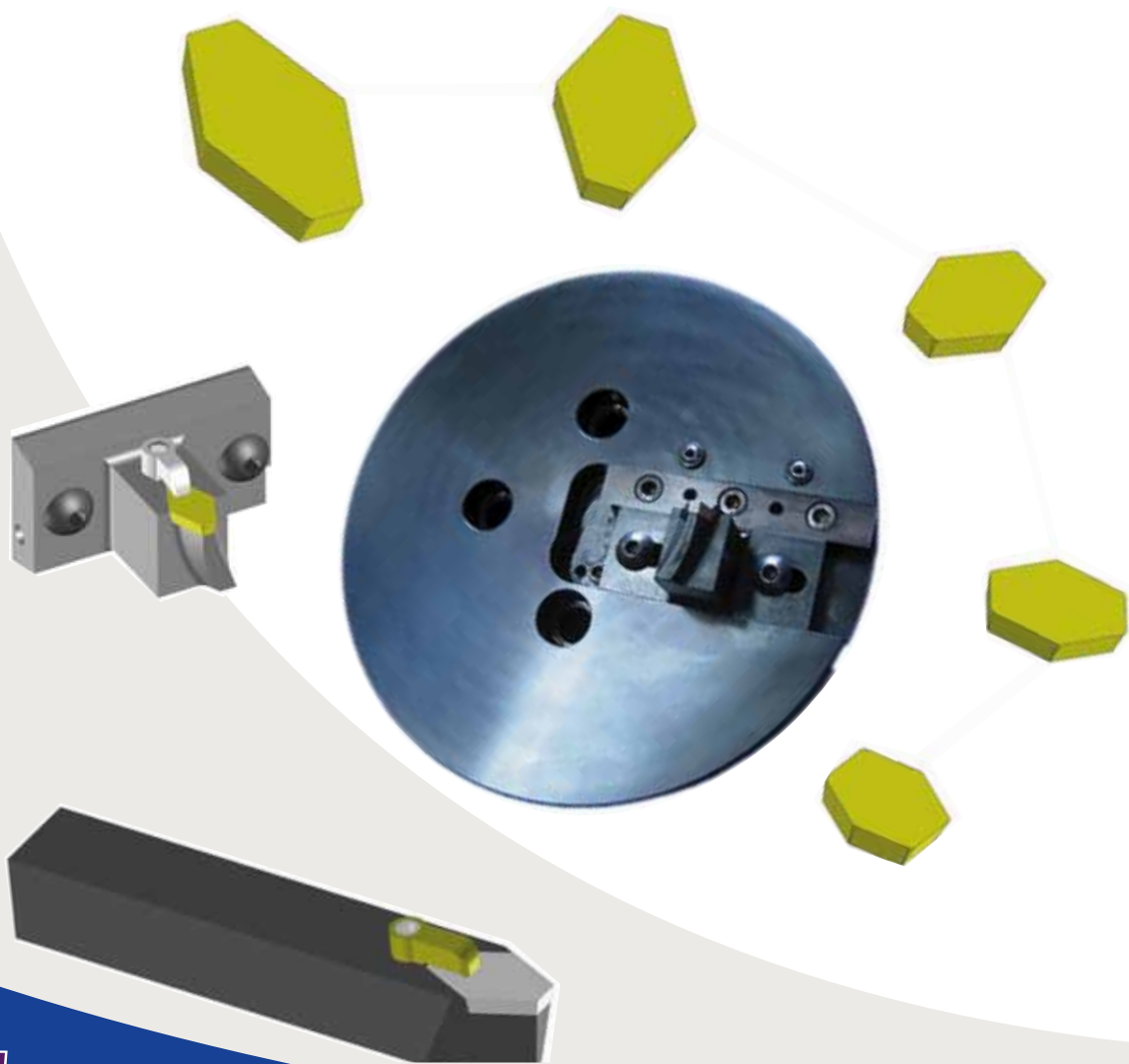

Solutions sur mesure pour votre usinage
Machining solutions especially for you

OUTILS POUR GORGE

JOINTS R ET BX



Sommaire

- **Plaquettes à Gorge pour Joints Type « R » & « BX »**
 - Correspondance des Plaquettes en fonction des numéros de joints **Page 04**

- **Porte-outils et Accessoires**
 - Références des Porte-outils avec plaquettes, accessoires et dimensions **Page 05**

- **Porte-outils et Accessoires**
 - Exemple et caractéristiques **Page 06**

- **Cassettes pour Plaquette à gorge**
 - Exemples, plan, photo **Page 07**

■ Outils à Gorge
Joints Type « R » & « BX »

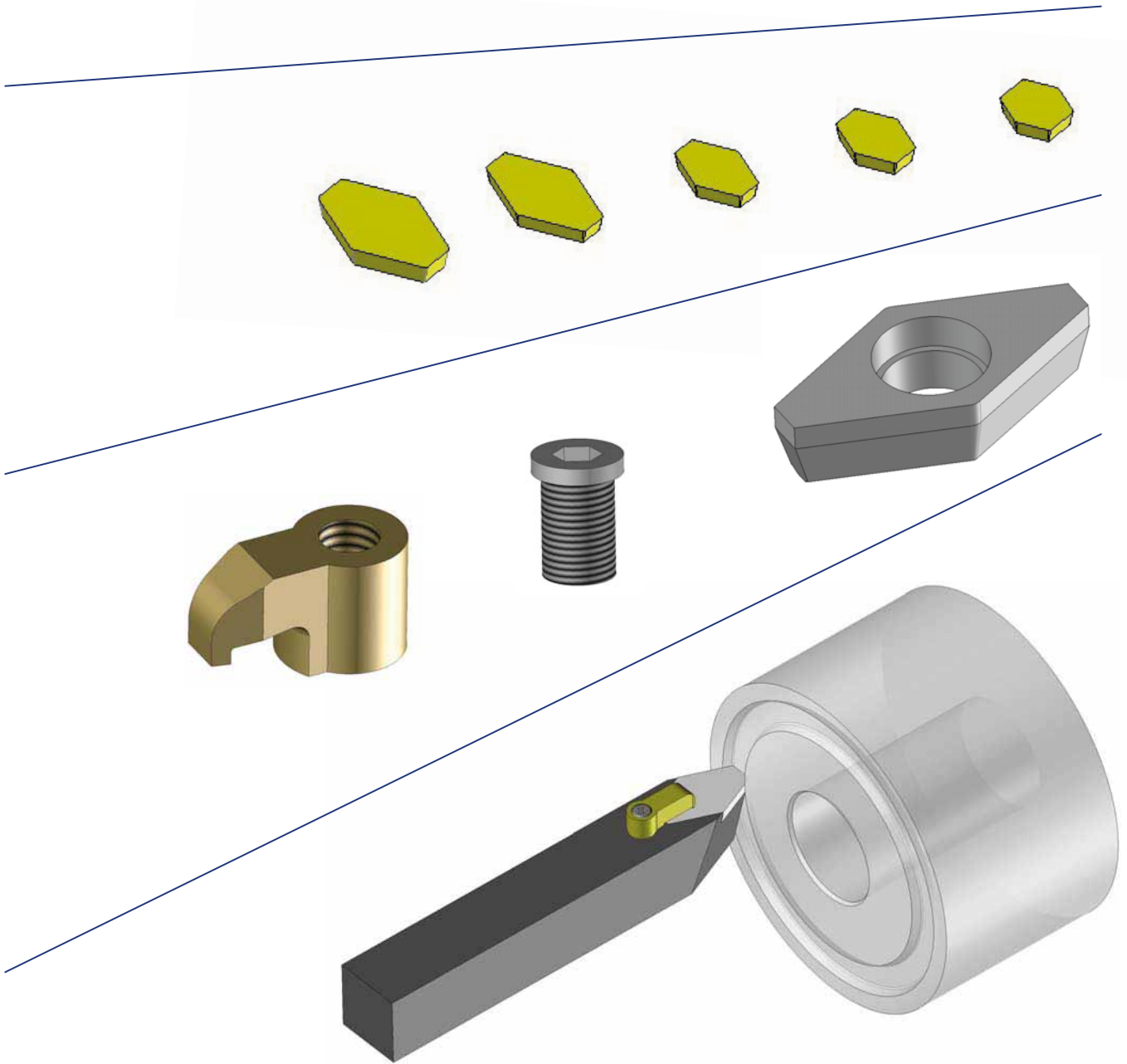

■ Correspondance des Plaquettes en fonction des numéros de joints

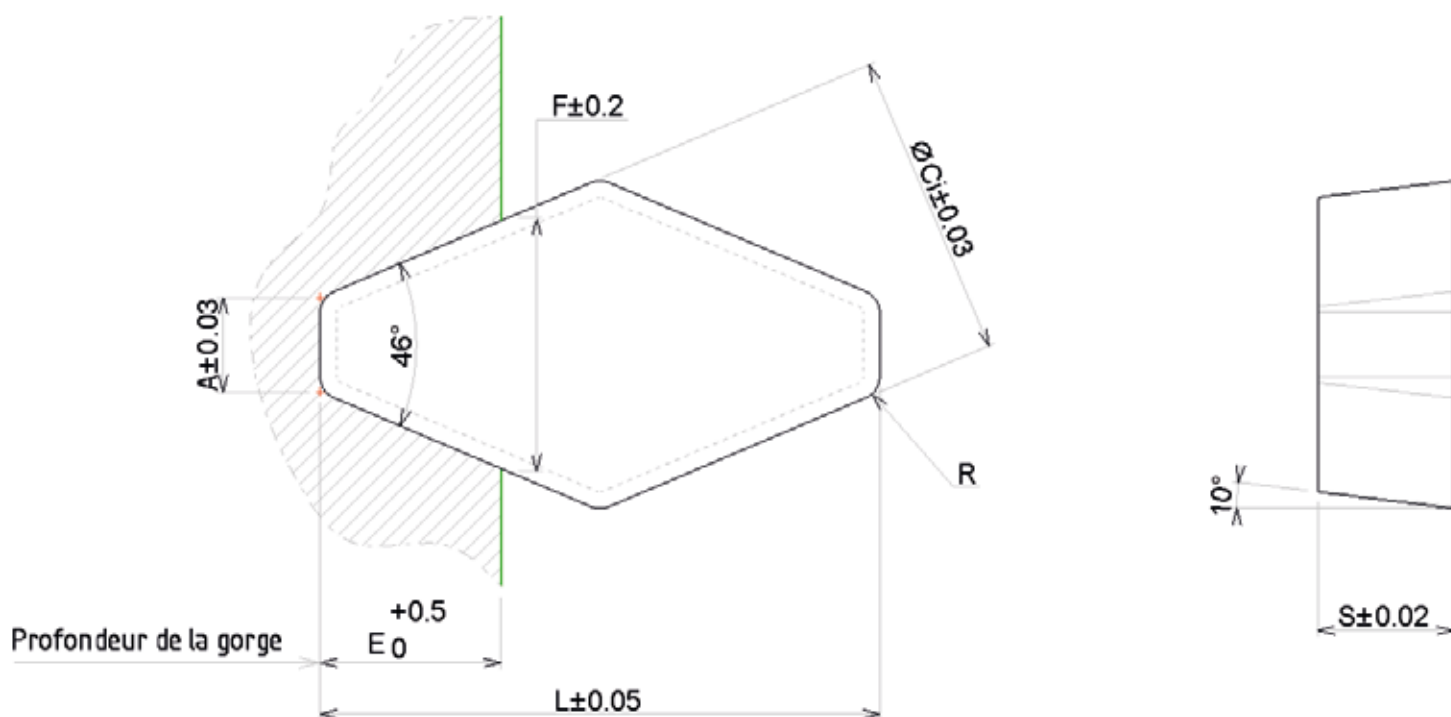

Référence Plaquette	N° de joints	E	F	A	R	Ci±0.03	S±0.2	L	Stock
12100020	13 ;15-20 ;22 ;25; 29 ;33 ;36 ;40 ;43 ;48 ;52	6.35	8.73	3.127	0.8	10.738	4.76	19.65	OUI
12100021	21 ; 23 ;24 ;26 ;27 ;31 ;34; 35 ; 37 ;39 ;41 ;44 ;45 ;49 ;53	7.87	11.91	5.017	0.8	14.74	4.76	25.9	OUI
12100022	28 ; 32 ; 46	9.65	13.49	5.085	1.5	14.74	4.76	25.74	OUI
12100023	38 ; 50	11.18	16.67	6.967	1.5				
12100024	42 ; 47	12.7	19.84	8.846	1.5				
12100025	51	14.22	23	10.716	1.5				
12100026	BX-150	5.56	11.48	6.523	0.8	14.55	4.76	21.81	
12100027	BX-151	5.56	11.89	6.933	0.8	14.55	4.76	20.73	
12100028	BX-152	5.95	12.70	7.412	0.8	14.55	4.76	19.61	
12100029	BX-153	6.75	14.12	8.152	0.8	14.55	4.76	17.97	
12100030	BX-154	7.54	15.44	8.802	0.8	14.55	4.76	16.365	
12100031	BX-155	8.33	17.78	10.471	0.8	26.62	6.35	43.46	
12100032	BX-156	11.11	23.44	13.771	0.8	26.62	6.35	35.69	

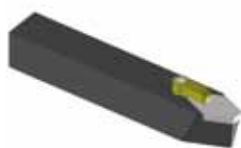
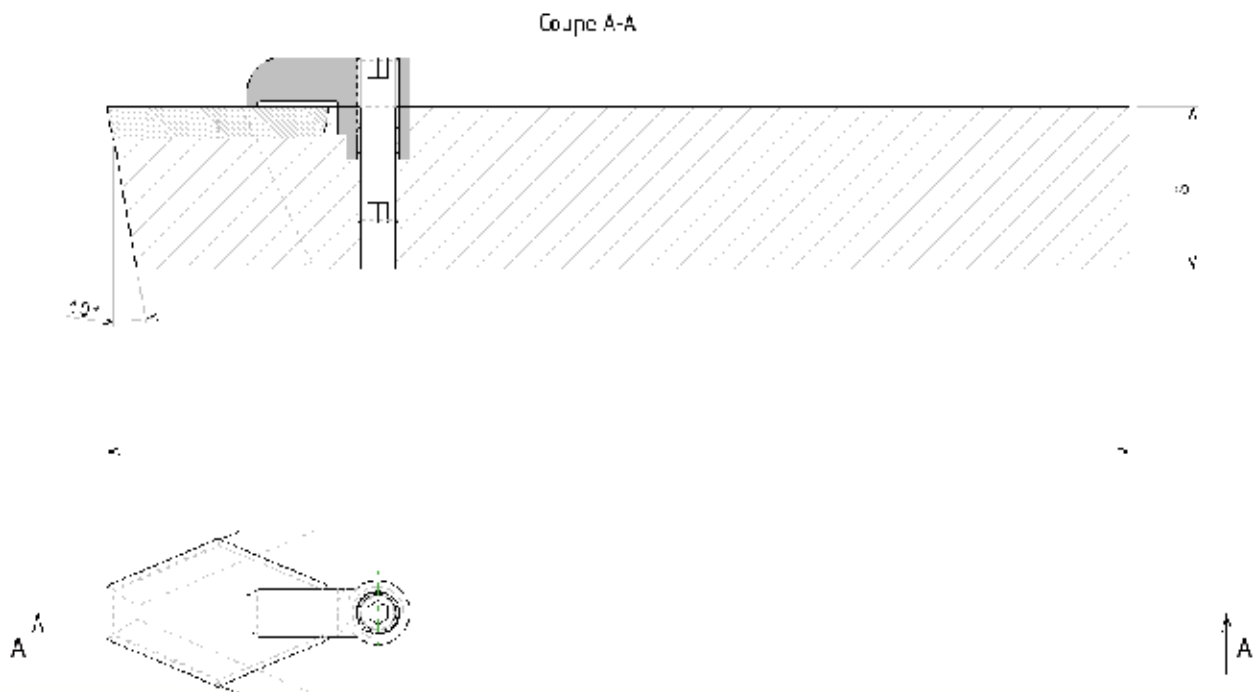

N° de joints	Référence Ensemble	L	B x H	Plaquette	Bride	Vis
13 ; 15-20 ; 22 ; 25 ; 29 ; 33 ; 36 ; 40 ; 43 ; 48 ; 52	12100001	150	25x25	12100020	12100010	12100011
21 ; 23 ; 24 ; 26 ; 27 ; 31 ; 34 ; 35 ; 37 ; 39 ; 41 ; 44 ; 45 ; 49 ; 53	12100002	150	25x25	12100021	12100010	12100011
	12100003	200	25x32			
28 ; 32 ; 46	12100004	170	25x32	12100022	12100010	12100011
	12100005	200	32x32			

■ Porte-Outil Rotatif et Réglable

Exemple d'une réalisation spéciale sur commande.

- Plateau pour cassette à gorge Type R et BX
- Attachement Nez de broche SA 50
- Capacité
 - Gorge R : R13 (Ø42.88) à R48 (Ø247.65)
 - Gorge BX : BX150 (Ø62.05) à BX156 (Ø218.44)

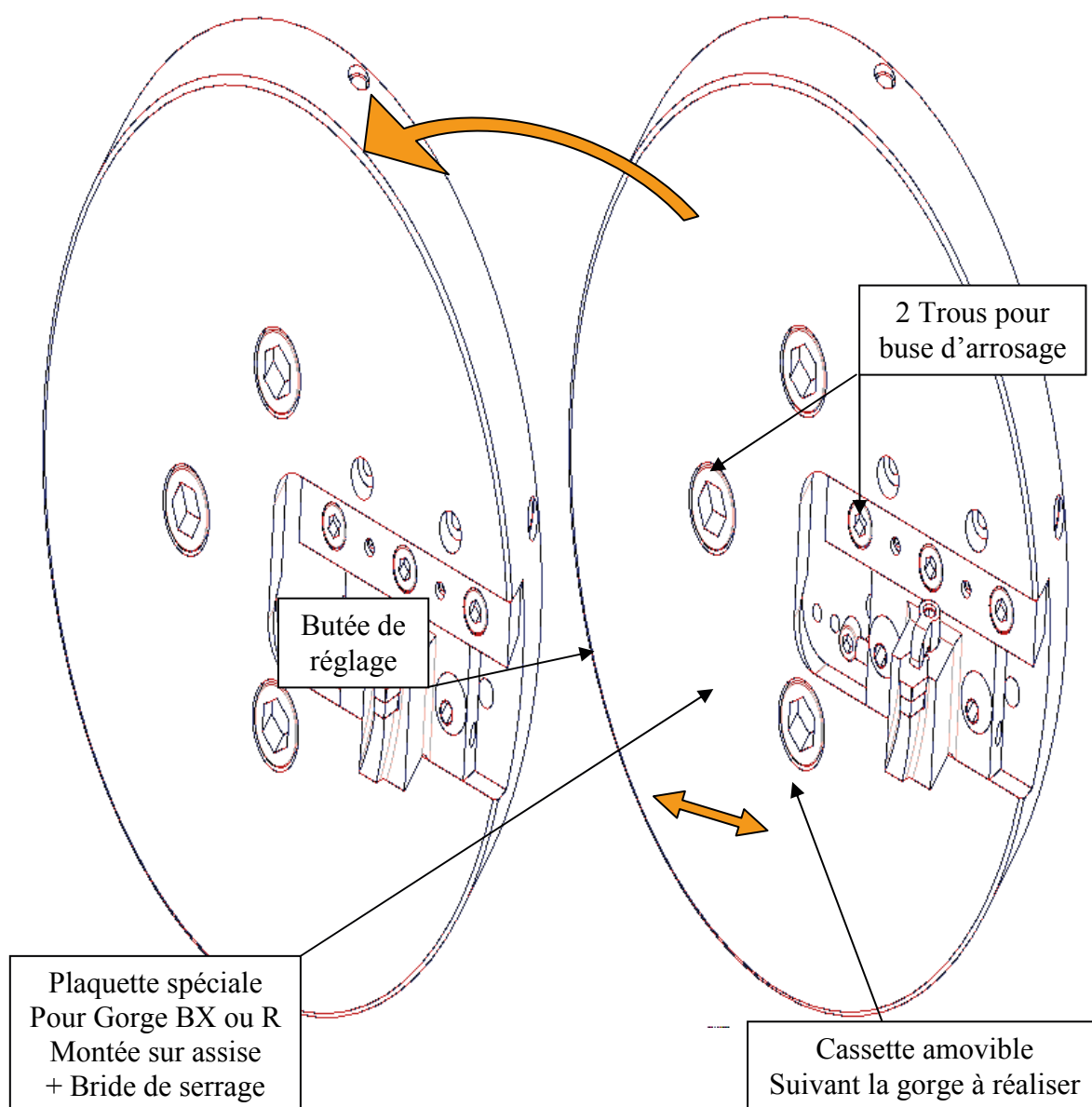

Cassette pour Gorge type R sur plateau 32100240

M10

38.7

68.65

Trous utilisés pour cette cassette

95

36.92

15.08

84

60

46°

(5.017)

Vis de réglage

Bride + vis

Cassette à gorge avec plaq. 12100021 pour gorge R41 - R44 - R45

Matériau	Nbre	Client :	Indice	Format
	1		0	A4
Date :		N°		

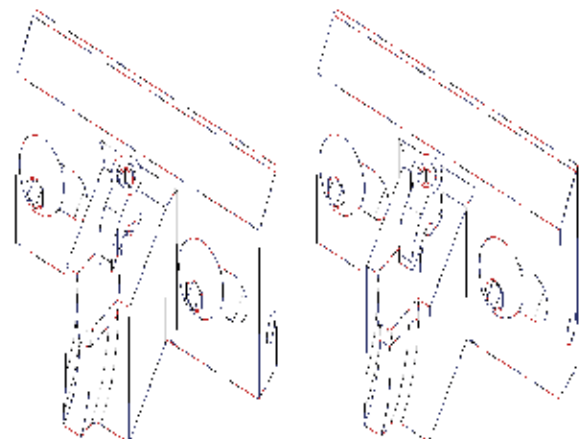

evatec tools®

Solutions sur mesure pour votre usinage
Machining solutions especially for you

CARBURE



PCBN / PCD



AÉRONAUTIQUE



TOURNAGE



USINAGE DE TROUS

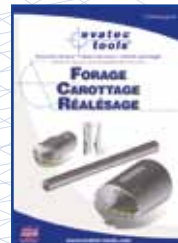

ATTACHEMENTS

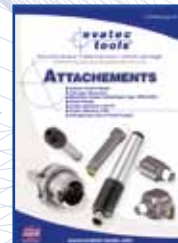

FRAISAGE

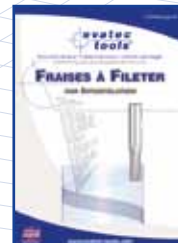

MÉTIERS / SPÉCIFIQUES



Téléchargez nos catalogues sur www.evatec-tools.com

Download our CATALOGS on www.evatec-tools.com

**evatools® evamet® carbex® gmo®
coriatec® create outillage®**

12, rue des Terres Rouges - Z.I. Metzange - 57100 Thionville

Tél. : 03 82 88 61 61 - Fax. : 03 82 88 33 19

E-mail : info@evatec-tools.fr

www.evatec-tools.com

