

# Sound-proof Central Granulator

SG-5080



Refer carefully to this manual before operation.

## ■ Coding Principle

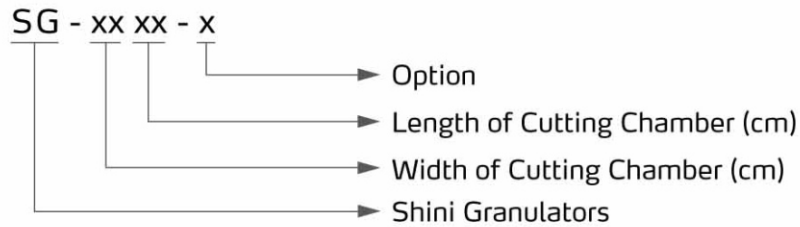

## ■ Features

### ● Fine finishing cutting chamber and convenient cutters installation

Components in the cutting chamber have been finely finished by CNC lathe, enjoying high accuracy. Besides, the machine is equipped with presetting knife jig, in which adjustment of cutters can be made. Therefore, the installation and adjustment of cutters becomes much easier, and the maintenance time of the machine can be saved.



Cutting Chamber

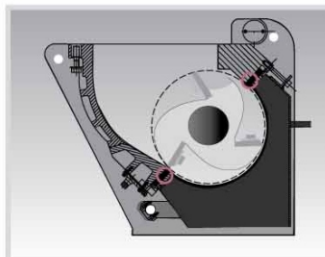

Two Fixed plus Three Rotating Blades (Low Cutting Point)

### ● High-efficiency cutting motor

The machine adopts Siemens high-efficiency motor, which has stable performance as well as safe operation and helps energy consumption,



### ● Multiple safety protection of control

Control circuit meets CE standard, and it has multiple protections including protection of motor overload, short circuit, phase default and phase order detection, ensuring safe operation of the machine.



# SG-50 Series

- **Sound-proofing machine**

The machine adopts enclosed soundproof box, and in the positions that may make noises, there are sound-absorbing cotton, which can efficiently reduce the noises made in the cutting process.



- **Automatic conveying device**

The machine is equipped with automatic conveying device of regrind materials, which is able to increase the conveying efficiency; materials are conveyed by blowers, which promote airflow and achieve air cooling of the cutting chamber to some extent. Thus, the room temperature of the cutting chamber can be reduced.



- **Cooling device of cutting chamber**

Cooling water device on the rear plate of cutting chamber can reduce the room temperature of cutting chamber and avoid the melt of regrind materials.



## ■ Application

SG-50 series granulators are applicable to granulate various kinds of plastic materials from injection molding, blow molding or extrusion molding, gradually inclined cutting and integrated power design offers a better cutting effect and a lower noise level.

## ■ Options

### Three Fixed plus Five Rotating Blades (High Cutting Point)

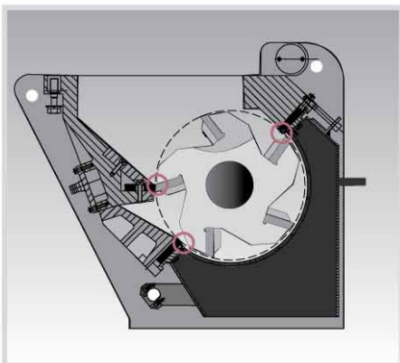

High cutting point fixed blades model has small inlet space and initially high cutting point. Thus its cutting force is not so strong, which enhances the reliability of cutting solid material. This design is suitable for granulating big solid material with thick wall and sheet. Based on the high cutting point of standard layout, a row of fixed blade is added and makes it a 3 rows of fixed blades so that cutting performance is higher than that of 2 rows of fixed blades. But 3 rows have the same design parameter, features and applications as the 2 rows.

### Special Screens

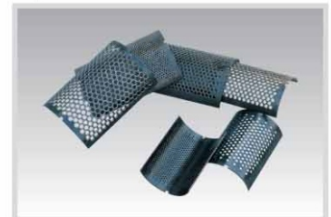

Special screen mesh sizes:  $\Phi 8$ ,  $\Phi 10$ ,  $\Phi 14$ ,  $\Phi 17$ ,  $\Phi 25$ (mm).

Add "SS + screen diameter" at the end of model code, e.g.:  $\Phi 8$ mm , add "SS08".

## Cyclone dust separator conveying device

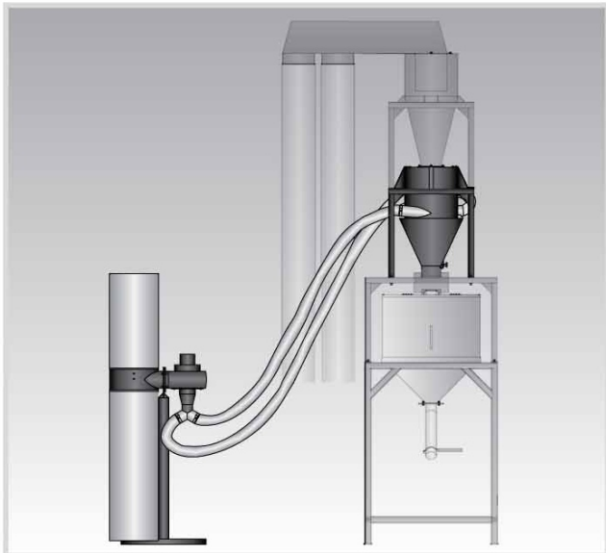

Dust Separator can separate the dust in the regrind for immediate recycle use. The dust will be kept in filter bag, thus working environment will remain clean. This device ensures full use of regrind to avoid material wasting and enhance the economy returns.

Add "DS" at the end of the model code.

## Feeding Hopper for Conveyor

Material feeding for traditional large granulators is quite a difficult matter. They are generally installed at a lower place or a platform must be built for material feeding. Shini has particularly designed the belt conveyor to easily convey the material into the cutting chamber of SG-50 series.

Add "BCF" at the end of the model code.



## Material Side Feed Pipe

The design of feeding hopper of traditional granulators is not suitable for longer pipes and section bars. We have designed material side feed pipe for convenient feeding of long materials.

Add "SF" at the end of the model code.



# SG-50 Series

## Outline Drawings

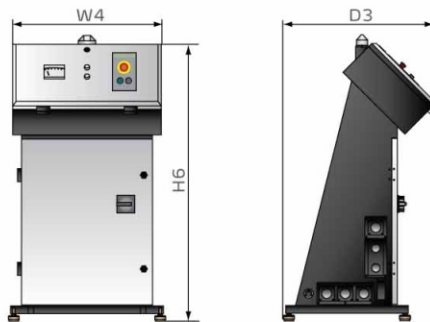
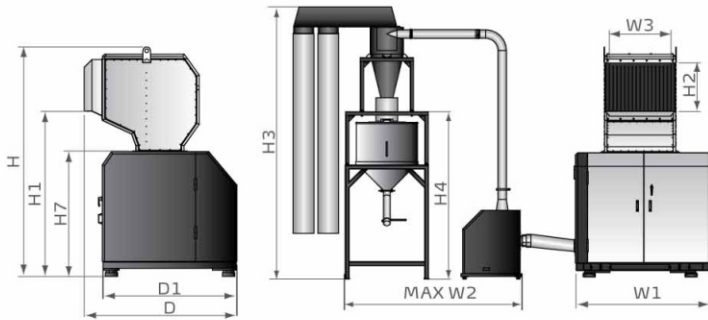

Control box

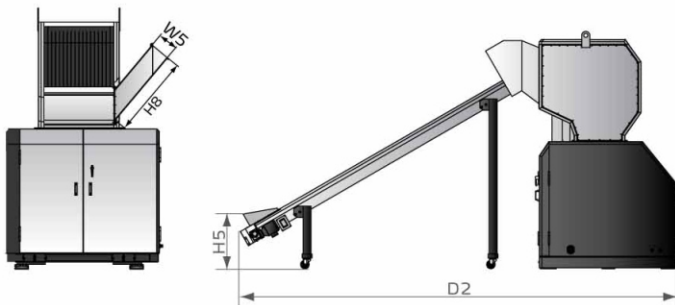

Side Feed Pipe is optional

Conveyor belt is optional

## Specifications

Model	SG-5080	SG-50110		
Motor Power (kW, 50/60Hz)	37	45		
Rotating Speed (rpm, 50/60Hz)	525	525		
Conveying Blower (kW, 50/60Hz)	7.5	7.5		
Handspike Motor Power (kW,50/60Hz)	0.25	0.25		
Material of Blades	SKD11	SKD11		
Quantity Fixed Blades(optional)	2×2 (2×3)	2×2 (2×3)		
Quantity of Rotating Blades	3×2 (5×2)	3×2 (5×2)		
Cutting Chamber	500 x 800	500 x 1100		
Max. Output	1100	1500		
Noise Level dB(A)	105-110	105-110		
Screen	Φ12mm/0.47"	Φ12mm/0.47"		
Dimension	mm	2980	2980	
	inch	117.3	117.3	
	H1 (mm)	mm	2150	2150
		inch	84.6	84.6
	H2 (mm)	mm	620	620
		inch	24.4	24.4
	H3 (mm)	mm	4085-4925	4085-4925
		inch	160.8-193.9	106.7-124.2
	H4 (mm)	mm	2510	2510
		inch	98.8	98.8
	H5 (mm)	mm	690	690
		inch	27.2	27.2
	H6 (mm)	mm	1260	1260
		inch	49.6	49.6
	H7 (mm)	mm	1610	1610
		inch	63.4	63.4
	H8 (mm)	mm	394	394
		inch	15.5	15.5
	D (mm)	mm	2000	2000
		inch	78.7	78.7
D1 (mm)	mm	1740	1740	
	inch	68.5	68.5	
D2 (mm)	mm	5470	5470	
	inch	215.4	215.4	
D3 (mm)	mm	690	690	
	inch	27.2	27.2	
W1 (mm)	mm	1740	2040	
	inch	68.5	80.3	
W2 (mm)	mm	2660	2660	
	inch	104.7	104.7	
W3 (mm)	mm	800	1100	
	inch	31.5	43.3	
W4 (mm)	mm	700	700	
	inch	27.6	27.6	
W5 (mm)	mm	215x215	215x215	
	inch	8.5x8.5	8.5x8.5	
Weight	kg	3280	3820	
	ib	7,231	8422	

Notes: 1) SKD11 is steel grade of Japanese JIS standard.

2) Maximum throughput of granulator is subject to the diameter and material of screen mesh. For granulating frame and shell materials, maximum throughput will be reduced about half.

3) Noise level varies with different materials and motor types.

4) Noise level is tested under conditions of 1m around the machine and 1.6m from the ground.

5) To avoid plastic form sticking to the blades, all materials should be crushed at normal temperature.

6) Power supply : 3Φ, 230/400/460/575VAC, 50/60Hz.

## 信易集團

地址: 台灣省新北市樹林區民和街23號

電話: +886 2 2680 9119

傳真: +886 2 2680 9229

Email: [shini@shini.com](mailto:shini@shini.com)

### 製造工廠

- 台灣
- 東莞
- 平湖
- 寧波
- 重慶
- 浦那

2018-03-15-04 Copyrights Reserved.

[www.shini.com](http://www.shini.com)