

**RESSORT**

**SPRING**

**FEDER**

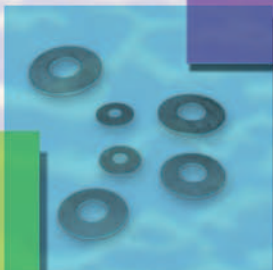
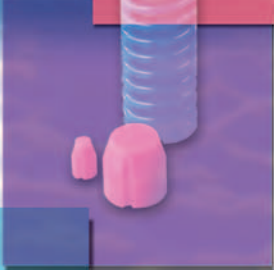
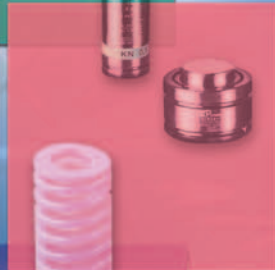

*Les  
formes  
de demain*

[www.rabourdin.fr](http://www.rabourdin.fr)



CE PLAN EST DISPONIBLE SUR LE SITE <http://www.rabourdin.fr>

# RABOURDIN

## INDUSTRIE

Accueil - standard - Bussy St Georges  
Tél : +33 (0)1 64 76 41 01  
Fax : +33 (0)1 64 76 41 02  
E-mail : [industrie@rabourdin.fr](mailto:industrie@rabourdin.fr)

Service canaux chauds  
Tél : +33 (0)1 64 76 41 36  
Fax : +33 (0)1 64 76 41 02  
E-mail : [canauxchauds@rabourdin.fr](mailto:canauxchauds@rabourdin.fr)

Service plaques usinées et corps de moule  
Tél : +33 (0)3 44 27 03 40  
Fax : +33 (0)3 44 27 03 42  
E-mail : [plaqueoxa@rabourdin.fr](mailto:plaqueoxa@rabourdin.fr)

Service télévente : produits standards  
Tél : +33 (0)1 64 76 41 00  
Fax : +33 (0)1 64 76 41 06  
E-mail : [televente@rabourdin.fr](mailto:televente@rabourdin.fr)

Service découpe - service technique  
Tél : +33 (0)1 64 76 41 50  
Fax : +33 (0)1 64 76 41 02  
E-mail : [decoupe@rabourdin.fr](mailto:decoupe@rabourdin.fr)

Service devis hors standard - vis spéciales  
Tél : +33 (0)1 64 76 41 21  
Fax : +33 (0)1 64 76 41 02  
E-mail : [devishstd@rabourdin.fr](mailto:devishstd@rabourdin.fr)



- **Depuis Paris Porte de Bercy :**  
Emprunter l'A4 en direction de Metz-Nancy. Après 25 km, emprunter la sortie 12 Marne-la-Vallée/Bussy-Saint-Georges, au rond point, prendre à gauche (puis voir plan)
- **Depuis Metz/Nancy par l'A4 :**  
Rejoindre l'A4 en direction de Paris. Emprunter la sortie 12 Marne-la-Vallée/Bussy-Saint-Georges, au rond-point prendre à droite (puis voir plan)
- **Depuis Lille / Roissy CH de Gaulle par l'A1 :**  
Rejoindre l'A1 en direction de Paris. Bifurquer vers l'A104 Soissons. Après 8 km, suivre Marne-la-Vallée A104. Après 18 km, suivre Metz/Nancy A4. Après 2 km emprunter la sortie 12 Bussy-Saint-Georges (puis voir plan)

**Distance depuis Paris : 26 km**



# RESSORT / SPRING / FEDER



REF. 270 ..... 2-4

RESSORT A GAZ CSR  
GAS SPRING CSR  
GASDRUCKFEDER CSR



REF. 272 ..... 14-20

RESSORT A GAZ SR  
GAS SPRING SR  
GASDRUCKFEDER SR



REF. 274 ..... 24-32

RESSORT A GAZ AR  
GAS SPRING AR  
GASDRUCKFEDER AR



REF. 276 ..... 39-43

RESSORT A GAZ AR/C  
GAS SPRING AR/C  
GASDRUCKFEDER AR/C

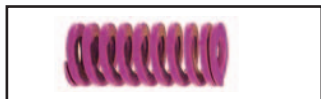

REF. 324 ..... 52-53

RESSORT CHARGE EXTRA LEGERE COULEUR VIOLET  
RECTANGULAR WIRE DIE SPRING PURPLE COLOUR LIGHT EXTRALOAD  
SYSTEM-DRUCKFEDER, PURPURROT

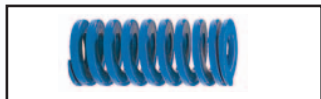

REF. 356 ..... 56-57

RESSORT CHARGE MOYENNE COULEUR BLEU  
RECTANGULAR WIRE DIE SPRING BLUE COLOUR MEDIUM LOAD  
SYSTEM-DRUCKFEDER, BLAU

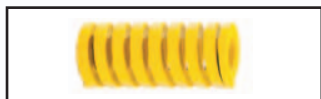

REF. 358 ..... 60-61

RESSORT CHARGE EXTRA FORTE COULEUR JAUNE  
RECTANGULAR WIRE DIE SPRING YELLOW COLOUR EXTRA LOAD  
SYSTEM-DRUCKFEDER, GELB

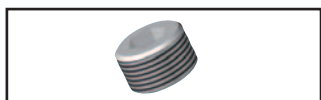

REF. 325 ..... 63

BOUCHON FILETE DE PRECONTRAINTE  
SET SCREWS FOR COMPRESSION SPRING ADJUSTMENT  
VERSCHLUSSSCHRAUBEN ALS VERSTELLBARER FEDERBODEN



REF. 387 ..... 65

AXE DE GUIDAGE  
GUIDE BOLT  
FÜHRUNGSBOLZEN



REF. 394 ..... 72

DEVETISSEUR DE POINÇON  
URETHANE STRIPPER  
ABSTREIFER

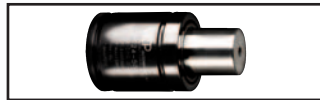

REF. 271 ..... 6-13

RESSORT A GAZ KC  
GAS SPRING KC  
GASDRUCKFEDER KC



REF. 273 ..... 21-23

RESSORT A GAZ KCR  
GAS SPRING KCR  
GASDRUCKFEDER KCR



REF. 275 ..... 33-38

RESSORT A GAZ AR/P  
GAS SPRING AR/P  
GASDRUCKFEDER AR/P



REF. 280-281 ..... 3-5  
REF. 282-289-283 ..... 44-45  
REF. 284-285-286 ..... 46-47-48  
REF. 287-288 ..... 49-50

FIXATION POUR RESSORTS A GAZ  
MOUNT FOR GAS SPRING  
BEFESTIGUNG FÜR GASDRUCKFEDER

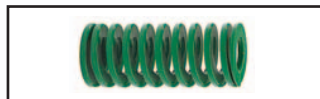

REF. 355 ..... 54-55

RESSORT CHARGE LEGERE COULEUR VERT  
RECTANGULAR WIRE DIE SPRING GREEN COLOUR LIGHT LOAD  
SYSTEM-DRUCKFEDER, GRÜN

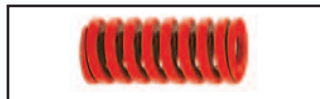

REF. 357 ..... 58-59

RESSORT CHARGE FORTE COULEUR ROUGE  
RECTANGULAR WIRE DIE SPRING RED COLOUR HEAVY LOAD  
SYSTEM-DRUCKFEDER, ROT



REF. 359 ..... 62

RESSORT CHARGE HYPER FORTE COULEUR BRONZE  
RECTANGULAR WIRE DIE SPRING BRONZE COLOUR HYPER LOAD  
SYSTEM-DRUCKFEDER, BRONZE

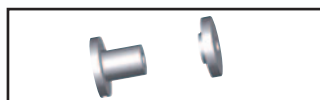

REF. 326 ..... 64

DISPOSITIF DE PRECONTRAINTE POUR RESSORT DE COMPRESSION  
SPRING UNITS  
FEDEREINHEITEN

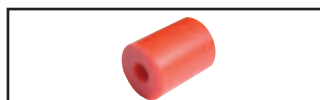

REF. 390 ..... 68-69  
REF. 391 ..... 70-71

RESSORT ELASTOMERE  
URETHANE SPRING  
ELASTOMERFEDER



REF. 395 ..... 72

DECOLLEUR ( polyuréthane )  
EJECTOR / CUSHION  
AUSHEBER / PUFFER

## RESSORT / SPRING / FEDER



REF. 396 ..... 73

JET CREUX ( polyuréthane )  
HOLLOW ROD ( PUR )  
FEDERSTAB /-STANGE



REF. 397 ..... 73

JET PLEIN ( polyuréthane )  
SOLID ROD ( PUR )  
FEDERSTAB /-STANGE



REF. 389 ..... 74

RONDELLE ENTRETOISE (laiton)  
SPACER (brass)  
DISTANZSCHEIBE (messing)



REF. 385 ..... 75-77

RONDELLE RESSORT  
DISC SPRING  
TELLERFEDER

## CENTRAGE / LOCATING / ZENTRIERUNG



REF. 501-3112 ..... 78-79  
REF. 502-503 ..... 80

GOUPILLE CYLINDRIQUE  
DOWEL PIN  
ZYLINDERSTIFT



REF. 523 ..... 81

GOUPILLE CYLINDRIQUE EN ACIER INOXYDABLE RINOX GR®  
EXTRACTABLE DOWEL PIN STAINLESS STEEL RINOX GR®  
ZYLINDERSTIFT MIT INNENGEWINDE RINOX GR®



REF. 521-3122 ..... 82-83

GOUPILLE CYLINDRIQUE A TROU TARAUDE  
EXTRACTABLE DOWEL PIN  
ZYLINDERSTIFT MIT INNENGEWINDE

## VISSERIE / SCREW / SCHRAUBE



REF. 1021 ..... 84

VIS EPAULEE A 6 PANS CREUX  
SHOULDER BOLT  
PASSCHRAUBE MIT INNENSECHSKANT



REF. 1031 ..... 85

VIS EPAULEE A 6 PANS CREUX INOX 17% Cr  
SHOULDER BOLT STAINLESS STEEL Cr 17%  
PASSCHRAUBE MIT INNENSECHSKANT INOX 17% Cr

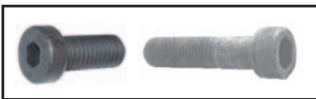

REF. 526-527 ..... 86-87

VIS TETE CYLINDRIQUE A 6 PANS CREUX  
HEXAGON SOCKET HEAD CAP SCREW  
ZYLINDERSCHRAUBE MIT INNENSECHSKANT



REF. 528 ..... 88

VIS TETE CYLINDRIQUE A 6 PANS CREUX NON FILETEE  
HEXAGON SOCKET HEAD CAP SCREW BLANK  
ZYLINDERSCHRAUBE MIT INNENSECHSKANT, ROHLING



REF. 530 ..... 89

VIS TETE FRAISEE A 6 PANS CREUX  
HEXAGON SOCKET COUNTERSUNK HEAD CAP SCREW  
SENKSCHRAUBE MIT INNENSECHSKANT



REF. 532-533 ..... 90

VIS A BILLE A RESSORT  
SPRING PLUNGER, SLOTTED  
FEDERNDEN DRUCKSTÜCK MIT SCHLITZ



REF. 531-535 ..... 91-92

VIS SANS TETE A 6 PANS CREUX BOUT PLAT  
HEXAGON SOCKET SET SCREW WITH FLAT POINT  
GEWINDESTIFT MIT INNENSECHSKANT



REF . . . . . Page	REF . . . . . Page	REF . . . . . Page	REF . . . . . Page
270 . . . . . 2-4	286 . . . . . 48	387 . . . . . 65	526 . . . . . 86
271 . . . . . 6-13	287 . . . . . 49	389 . . . . . 74	527 . . . . . 86-87
272 . . . . . 14-20	288 . . . . . 50	390 . . . . . 68-69	528 . . . . . 88
273 . . . . . 21-23	289 . . . . . 44	391 . . . . . 70-71	530 . . . . . 89
274 . . . . . 24-32	324 . . . . . 52-53	394 . . . . . 72	531 . . . . . 91
275 . . . . . 33-38	325 . . . . . 63	395 . . . . . 72	532 . . . . . 90
276 . . . . . 39-43	326 . . . . . 64	396 . . . . . 73	533 . . . . . 90
280 . . . . . 3	355 . . . . . 54-55	397 . . . . . 73	535 . . . . . 92
281 . . . . . 5	356 . . . . . 56-57	501 . . . . . 78	1021 . . . . . 84
282 . . . . . 44	357 . . . . . 58-59	502 . . . . . 80	1031 . . . . . 85
283 . . . . . 45	358 . . . . . 60-61	503 . . . . . 80	3112 . . . . . 79
284 . . . . . 46	359 . . . . . 62	521 . . . . . 82	3122 . . . . . 83
285 . . . . . 47	385 . . . . . 75-77	523 . . . . . 81	



- F** Tous les vérins conçus et fabriqués par VEP Automation suivent une démarche correcte qui fait partie de la directive communautaire PED (directive sur les récipients à pression), notamment l'article de la directive 97/93/CE qui récite: le volume est  $> 1 \text{ dm}^3$  et  $\text{PS} \cdot \text{V}$  est  $> 50 \text{ Bars} \cdot \text{dm}^3$  ou quand  $\text{PS} > 1000 \text{ Bars}$ .
- GB** All the cylinders designed and manufactured by VEP Automation follow a correct procedure according to the European Community PED directive (pressure equipment directive). In particular section 3 of directive 97/93/CE which states that: the volume is  $> 1 \text{ dm}^3$  and  $\text{PS} \cdot \text{V}$  is  $> 50 \text{ Bar} \cdot \text{dm}^3$  or when  $\text{PS} > 1000 \text{ Bar}$ .
- D** Alle von VEP Automation entwickelten und hergestellten Zylinder werden einem korrekten Prüfablauf unterzogen, welcher der PED Richtlinie der Europäischen Union (für Druckbehälter) entspricht, und zwar dem Art. 3 der EG Richtlinie: 97/93/CE, welche folgendes vorsieht: Das Volumen ist  $> 1 \text{ dm}^3$  und  $\text{PS} \cdot \text{V}$  ist  $> 50 \text{ Bar} \cdot \text{dm}^3$  oder wenn  $\text{PS} > 1000 \text{ Bar}$ .

# CARACTERISTIQUES ET TYPES / FEATURES AND TYPES / MERKMALE UND TYPOLOGIEN

## CSR - AR - AR/P - AR/C - KC - KCR

(img. 1)

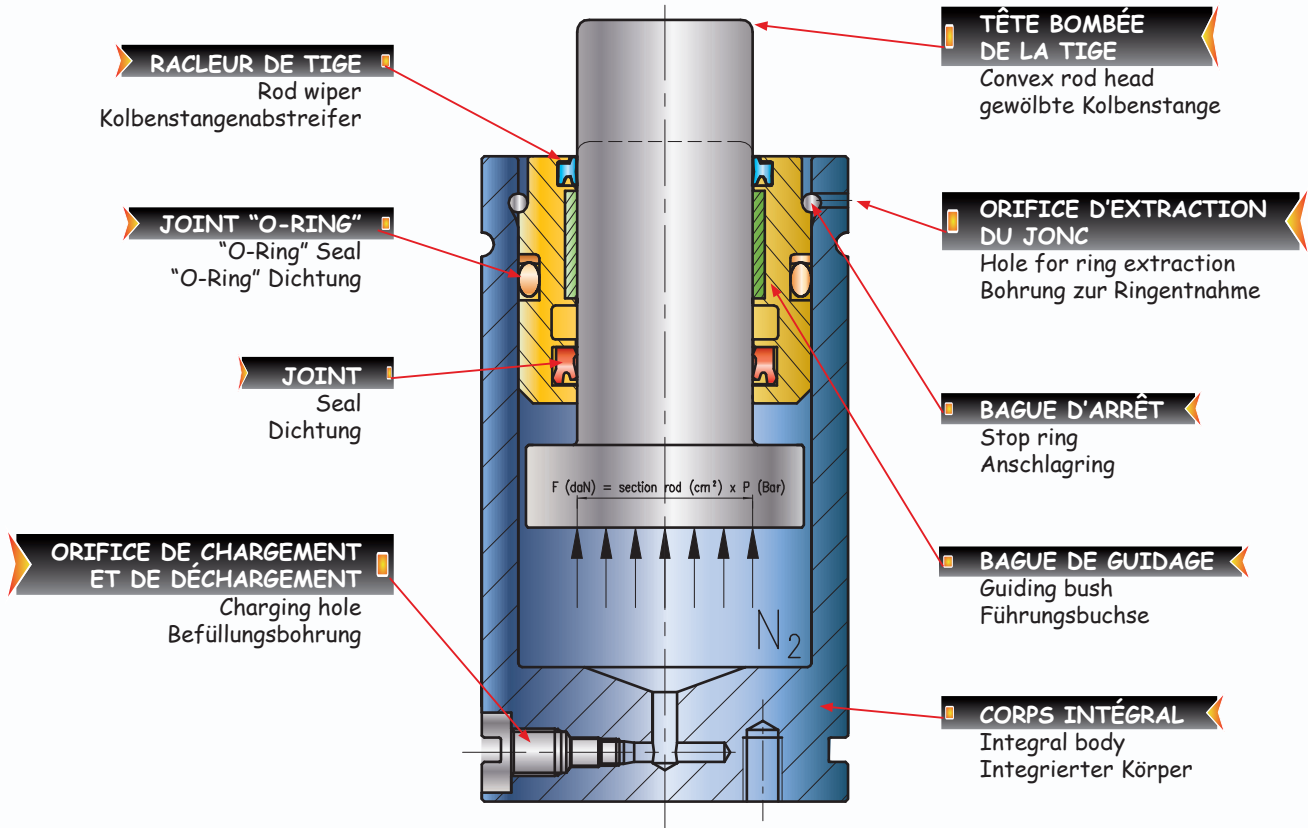

## SR

(img. 2)

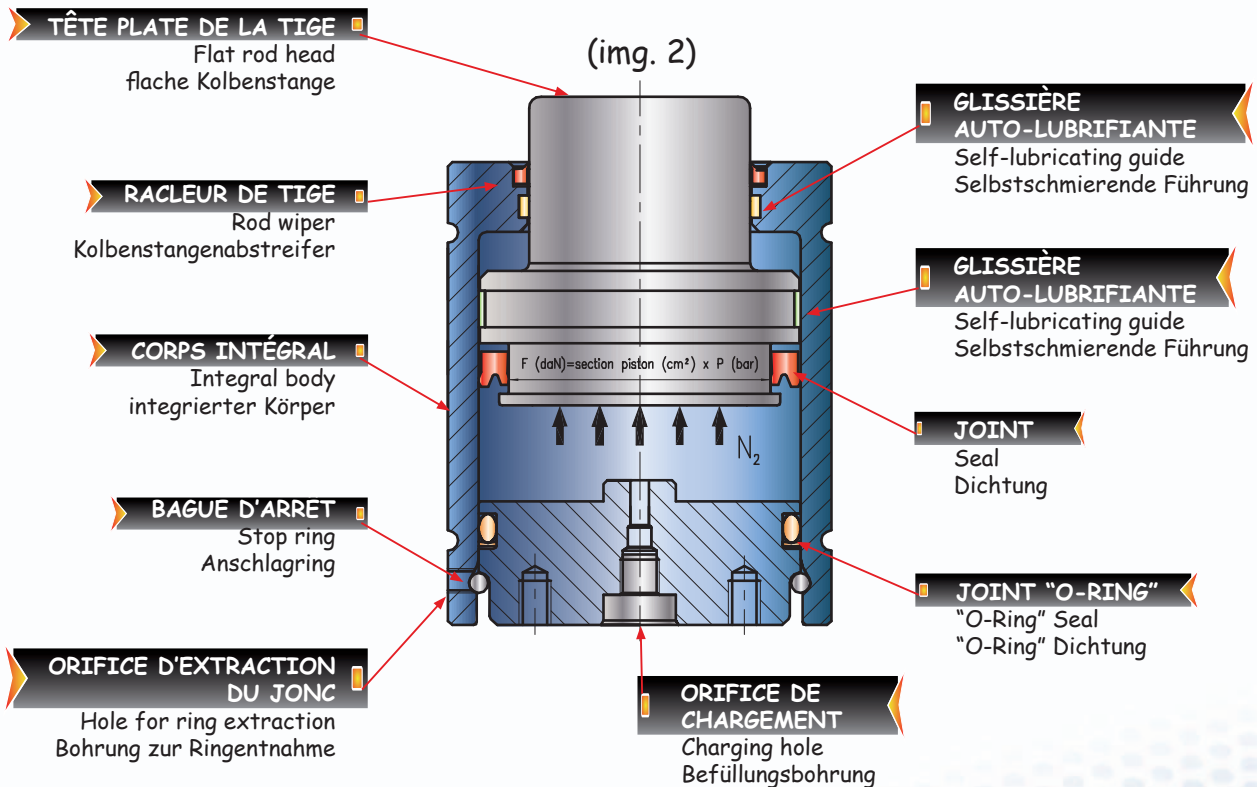

## CARACTÉRISTIQUES ET TYPES DE VÉRINS

Les **principaux composants** des vérins VEP comme le corps, la tige et l'embout sont réalisés en acier à haute résistance mécanique et soumis à des traitements thermiques et à des finitions de la surface qui garantissent des performances élevées et une longue durée. Les **joints** d'étanchéité et les bagues de guidage sont d'excellente qualité et sont sélectionnés après une évaluation approfondie de leurs caractéristiques. Le **système de lubrification** interne de chaque vérin garantit une plus longue durée des parties coulissantes et réduit remarquablement les interventions de maintenance en augmentant la productivité. Les **essais sévères** effectués sur le produit fini ont permis de tester le fonctionnement de chaque type de vérin dans des conditions particulièrement lourdes ainsi que la fiabilité au fil du temps, afin de garantir à l'utilisateur un standard de qualité supérieure à la moyenne. Les vérins à gaz comprennent plusieurs familles selon la taille et les forces initiales: **CSR; AR; AR/P; AR/C; KC; KCR** et **SR**.

## FONCTIONNEMENT ET CONDITIONS D'UTILISATION

L'azote est un gaz inerte qui est introduit dans le vérin jusqu'à atteindre une pression maximum de 15 MPa. Dans un état de repos, la pression agit sur la section de la tige-piston (**img. 1-pag. V**), en poussant vers l'extérieur avec une force résultante égale à la force initiale du vérin.

$$F \text{ (N)} = \text{section de la tige (mm}^2\text{)} \times \text{pression (MPa)}$$

$$\text{Exemple: } F = 314 \text{ mm}^2 \times 15 \text{ MPa} = 4710 \text{ N} = 471 \text{ daN}$$

Pendant le cycle de fonctionnement, la tige rentre dans le corps, comprime et diminue le volume du gaz contenu dans la chambre et augmente la force. Le vérin a un comportement semblable à celui d'un ressort mécanique traditionnel, mais, contrairement à ce dernier, ne nécessite d'aucune pré-contrainte initiale. Les vérins peuvent fonctionner en toutes positions sans être lubrifiés. En effet, ils sont hermétiquement fermés et conservent donc, pendant leur fonctionnement, le lubrifiant spécial introduit lors du montage. Après une période d'inactivité de l'installation, il convient de faire accomplir aux vérins quelques cycles complets afin d'optimiser l'étanchéité des joints. Il est préférable d'éviter des conditions de surchauffe qui provoqueraient des augmentations de pression à l'intérieur des vérins. Il est conseillé de ne pas dépasser une vitesse linéaire de la tige de 12 m/minute; cette valeur correspond à environ 1/5 de la valeur admise pour les joints utilisés. Le rythme de travail est calculé selon la formule suivante:

$$n = \frac{W}{C \times 2}$$

**W** est la vitesse de la tige (mm/minute)  
**C** est la course (mm)

Exemple: Si un vérin effectue une course de 150 mm, à la vitesse de 8000 mm/minute, le résultat sera:

$$n = \frac{8000}{150 \times 2} = 27 \text{ cycles par minute}$$

La pression maximum de chargement est 15MPa; cette valeur permet d'atteindre une pression finale en compression de ~ 25MPa. Aucun bouchon de protection n'est monté sur les vérins car la réalisation très robuste de ces derniers suffit à garantir une grande marge de fiabilité et de sécurité.

## DURÉE DE VIE DES VÉRINS À GAZ

S'ils sont installés correctement et s'ils fonctionnent sous des conditions normales d'utilisation, les vérins à gaz sont garantis pour un développement minimum de course de 75000 mètres linéaires au total. Cette mesure est le résultat de la somme des courses d'avance et de retour de la tige. Sous des conditions de travail critiques ou pour des causes externes qui entraînent un mauvais fonctionnement du produit, une intervention de maintenance peut s'avérer nécessaire en vue de remplacer les joints d'étanchéité ou les parties endommagées. L'utilisateur peut effectuer la maintenance au moyen des procédures et des outils indiqués dans ce catalogue.

## TEMPÉRATURE DE FONCTIONNEMENT

La température maximum de fonctionnement est 80°C. La variation de la température dans le vérin détermine la variation de la pression de chargement: l'augmentation d'1° C correspond à une augmentation de 0,33 % de la pression.

## AVERTISSEMENTS

Afin que les vérins à gaz puissent fonctionner longtemps et dans les conditions les meilleures, il est opportun que, lors de l'utilisation, l'utilisateur respecte les précautions suivantes:

- Éviter toutes interventions ou tous endommagement de corps et tiges.
- Ne pas enlever avant l'utilisation les protections des tiges car des chocs accidentels peuvent endommager les surfaces de ces dernières.
- Les vérins doivent être chargés uniquement avec gaz azote N<sub>2</sub>.
- Le chargement doit être effectué lorsque la tige est entièrement tirée.
- Ne pas charger à des pressions supérieures à 15MPa.

## IDENTIFICATION

Tous les vérins à gaz sont identifiés avec clarté au moyen d'un marquage sur le corps, comme il est prévu par la réglementation ISO; les vérins rentrent dans la directive communautaire PED (97/23/CE).

## GARANTIE

La garantie est valable 1 année à partir de la mise en marche du vérin. VEP Automation est le responsable au cas où le produit ne correspond pas aux conditions de fabrication requises et aux standards de qualité garantis. Le fabricant ne répond pas des dommages présumés provoqués par une utilisation impropre ou non conforme aux indications fournies par le présent catalogue et décline toute responsabilité pour toutes manipulations éventuelles des vérins, erreurs de fixation, utilisation de pièces de rechange non originales, fautes de calcul concernant l'installation et de choix des dimensions, chocs et égratignures ou tous signes présents sur les tiges qui peuvent avoir compromis le fonctionnement ou le maintien de la pression.

## CHOIX DES VÉRINS

Pour le choix du type de vérin, il faut considérer que l'augmentation de pression lors de la compression de la tige peut varier de 50 % à 60 % selon le type de vérin choisi. Par exemple, un vérin AR 15, ayant une course utile de 155 mm, chargé à la pression de 15MPa, atteint en position fermée une pression d'environ 23,5MPa. La force produite varie de 1500 daN à 2400 daN (données indiquées dans les diagrammes).

**Le choix des vérins peut être effectué selon les modes suivants:**

- Évaluer le nombre de vérins qui peuvent être placés dans la zone disponible ;
- Établir la charge en daN nécessaire pour chaque vérin, augmentée d'au moins 10%, aussi bien dans des conditions d'ouverture que de fermeture des vérins et établir la course nécessaire ;
- Choisir le vérin sur la base de la charge et de la course demandée, en se basant sur les forces initiales développées selon les différentes pressions de chargement (données indiquées dans les diagrammes).

**Les vérins peuvent fonctionner de façon autonome ou être reliés à un système.**

- Ils peuvent être chargés individuellement et donc positionnés dans les logements prévus à cet effet, ou bien fixés à l'aide de brides.
- Ils peuvent être reliés entre eux afin de limiter la force si besoin.
- Ils peuvent être reliés à un compensateur, au cas où pendant le travail une augmentation plus faible de la force s'avère nécessaire.

## CYLINDER FEATURES AND TYPOLOGY

The **main components** of VEP cylinders, such as the body, rod and the ferrule are made of highly resistant steel subjected to heat treatments and surface finishing to ensure high performance and long life.

The **piston rod seals** and guide rings are very high quality, selected after careful evaluation of their features.

The **internal lubrication** system of each cylinder guarantees longer life of sliding parts, heavily reducing maintenance operations and increasing productivity.

The **stringent tests** carried out on the finished product for every type of cylinder under particularly tough operating conditions ensure reliability over the course of time to guarantee the user a quality standard that is above average.

The nitrogen gas cylinders comprise different families according to their initial forces and dimensions: **CSR; AR; AR/P; AR/C; KC; KCR** and **SR**.

## OPERATION AND WORKING CONDITIONS

Nitrogen is an inert gas and it is sent inside the cylinder until the maximum pressure of 15 MPa is reached. In resting conditions the pressure acts on the piston-rod section (**img. 1-pag. V**), and pushes it outwards with the same force as the cylinder initial force.

$$F \text{ (N)} = \text{rod section (mm}^2\text{)} \times \text{pressure (MPa)}$$

$$\text{Example: } F = 314 \text{ mm}^2 \times 15 \text{ MPa} = 4710 \text{ N} = 471 \text{ daN}$$

During the operating cycle the rod reverses inside the body, compressing and decreasing the volume of the gas contained inside the chamber, causing the force to increase.

The cylinder has a behaviour similar to that of traditional mechanical springs, but unlike these it does not need any initial preloading. The cylinders can work in any position without being lubricated. Being hermetically sealed, while working they keep inside the special lubricant inserted during assembly. After a period of inactivity of the system, it is advisable to carry out a few complete cycles of the cylinders to optimise the sealing. It is preferable to avoid overheating, which would cause a rise in the pressure inside the cylinders. We advise not to exceed 12 mt/minute as linear speed of the rod, which corresponds to about 1/5 of the permissible speed for the seals used. The working rate can be calculated with the following formula:

$$n = \frac{W}{C \times 2}$$

*W* is the rod speed (mm/minute)  
*C* is the stroke (mm)

Example: If a cylinder performs a stroke of 150 mm, at a speed of 8000 mm/minute, the result will be:

$$n = \frac{8000}{150 \times 2} = 27 \text{ cycles per minute}$$

The maximum charging pressure is 15MPa; with this value the final pressure reached in compression is ~25MPa.

Safety caps are not fitted on the cylinders, since the particularly sturdy structure is enough to ensure a broad margin of reliability and safety.

## NITROGEN CYLINDER LIFE

If correctly installed and in normal conditions of use the nitrogen cylinders are guaranteed for a minimum total stroke extension of 75000 linear metres.

This measurement is given by the sum of the rod forward and return strokes. In critical working conditions or if external causes determine faulty operation of the product, a maintenance operation may be necessary to replace the seals or damaged parts. The user can carry out maintenance with the tools and procedures described in this catalogue.

## OPERATING TEMPERATURE

The maximum permissible operating temperature is 80°C.

The temperature change inside the cylinder causes a change in the charging pressure: an increase of 1° C corresponds to an increase in pressure of 0.33%.

## WARNINGS

In order to obtain longer and better life of the cylinders, the user should take the following precautions during use:

- Avoid operations or damage on the bodies or rods.
- Do not remove the rod protections before use, accidental shocks can damage the surface.
- The cylinders must be charged only with N<sub>2</sub> nitrogen gas.
- Charging must be performed with the rod pulled out completely.
- Never charge with pressures above 15MPa.

## IDENTIFICATION

All nitrogen cylinders are clearly identified by a marking on the body, as specified by ISO standards and they comply with the PED community directive (97/23/CE).

## GUARANTEE

The guarantee lasts 1 year starting from when the cylinder is put into operation. VEP Automation is responsible if the product fails to meet the guaranteed manufacturing and quality requirements. The manufacturer is not liable for presumed damages caused by improper use or the failure to follow the instructions given in this catalogue. The manufacturer is not considered liable for any tampering with the cylinders, errors in fastening, use of no original spare parts, incorrect system calculations and the choice of wrong sizes, knocks and scratches or marks on the rods that may have compromised operation or pressure tightness.

## CHOICE OF CYLINDERS

For the choice of the type of cylinder, it is necessary to consider that the pressure increase during rod compression can vary from 50% to 60% depending on the type of cylinder chosen. For example a cylinder of the AR 15 series, with a useful stroke of 155 mm, charged at a pressure of 15MPa, reaches a pressure of approximately 23.5MPa in the closed position.

The force produced varies between 1500 daN and 2400 daN (data given in the diagrams).

**The cylinders can be chosen in the following ways:**

- Calculate how many cylinders can be placed in the area available;
- Establish the charge in daN needed for each cylinder, increased by at least 10%, both in cylinder opening and closing conditions and establish the stroke required;
- Choose the cylinder according to the charge and stroke required on the basis of the nominal forces developed according to the various charging pressures (data given in the diagrams).

**The cylinders can work individually or connected in a system.**

- They can be charged individually and then positioned in their housings or fastened with special flanges.
- They can be connected to one another on the die through a control panel and a network of tubes and fittings.
- The cylinders can be connected to a compensation chamber, if a lower increase of the force is needed during work.

## ZYLINDERMERKMALE UND TYPEN

Die **Hauptbestandteile** der VEP Zylinder, wie der Körper, Kolbenstange und Nutnutter, bestehen aus Stahl mit hoher mechanischer Widerstandsfähigkeit und werden einer Wärmebehandlung und derartigen Oberflächenbehandlungen unterzogen, die ihre Leistungen auf Langzeit garantiert.

Die **Dichtungen** und die Führungsringe sind aus bester Qualität und wurden nach sorgfältiger Bewertung ihrer Eigenschaften ausgewählt.

Das **Schmiersystem** im Inneren der Zylinder garantiert eine längere Lebensdauer der Gleit teile, verringert drastisch die Wartung sein schritte und verbessert so die Produktivität.

Durch **die strengen Endkontrollen** auf das Fertigprodukt wird für jeden Zylindertyp nicht nur der Betrieb unter ganz besonders schwierigen Bedingungen getestet, sondern auch die Zuverlässigkeit, um dem Benutzer einen Gütestandard zu garantieren, der weit über dem Durchschnitt liegt. Die Stickstoffzylinder umfassen je nach Anfangskraft und Abmessung folgende Serien: **CSR; AR; AR/P; AR/C; KC; KCR** und **SR**.

## BETRIEB UND ARBEITSBEDINGUNGEN

Stickstoff ist ein träges Gas und wird bis zur Erreichung eines maximalen Drucks von 15 MPa in den Zylinder eingefüllt. Im Ruhestand wirkt der Druck auf den Kolbenstange-Kolben-Querschnitt ein (**img. 1-pag. V**), und stößt mit einer Kraft gleich der Anfangskraft des Zylinders nach aussen.

$$F \text{ (N)} = \text{Kolbenstangendurchschnitt (mm}^2\text{)} \times \text{Druck (MPa)}$$

$$\text{Beispiel: } F = 314 \text{ mm}^2 \times 15 \text{ MPa} = 4710 \text{ N} = 471 \text{ daN}$$

Während dem Arbeitszyklus fährt die Kolbenstange in den Körper, komprimiert und verringert das in der Kammer enthaltene Gasvolumen und bewirkt eine Kraftzunahme. Der Zylinder verhält sich in gleicher Weise wie eine normale mechanische Feder, benötigt aber, im Gegensatz zu dieser, keinerlei anfängliche Vorladung. Die Zylinder können in jeglicher Position ohne Schmierung arbeiten. Da sie hermetisch verschlossen sind, bleibt das bei Montage eingeführte Schmiermittel im Inneren unverändert erhalten. Nach längerem Stillstand der Anlage empfiehlt es sich, dass die Zylinder einige komplette Zyklen zur Optimierung der Dichtheit der Dichtungen ausführen. Überhitzungen, die eine Druckzunahme im Zylinderinneren verursachen, sind zu vermeiden.

Die lineare Geschwindigkeit der Kolbenstange von 12 m/Minute sollte nicht überschritten werden, dieser Wert entspricht ca. 1/5 des für die verwandten Dichtungen zulässigen Wertes.

Die Berechnung des Arbeitstaktes wird durch folgende Gleichung gegeben:

$$n = \frac{W}{C \times 2}$$

**W** ist die Kolbenstangengeschwindigkeit (mm/Minute)  
**C** ist der Hub (mm)

Beispiel: Bei einem Zylinderhub von 150 mm erhält man bei einer Geschwindigkeit von 8000 mm/Minute:

$$n = \frac{8000}{150 \times 2} = 27 \text{ Zyklen pro Minute}$$

Der maximale Ladedruck beträgt 15MPa; bei diesem Wert beträgt der bei Komprimierung erreichte Enddruck ~ 25MPa. Auf die Zylinder werden keine Sicherheitsstopfen montiert, da die äußerst robuste Herstellungsart einen weiten Spielraum an Zuverlässigkeit und Sicherheit garantiert.

## LEBENSDAUER DER STICKSTOFFZYLINDER

Bei korrektem Einbau und unter normalen Arbeitsbedingungen werden die Stickstoffzylinder für einen minimalen Hub garantiert, der insgesamt 75000 m entspricht. Dieser Wert ergibt sich aus der Summe des Vor- und Zurückschnellens der Kolbenstange. Bei kritischen Arbeitsbedingungen oder bei Betriebsstörungen durch externe Ursachen können Wartung sein schritte für Austausch der Dichtungen oder Ersatz von beschädigten Teilen notwendig werden. Der Benutzer kann diese Einschritte mit den in diesem Katalog beschriebenen Werkzeugen und Vorgängen selbst durchführen.

## ARBEITSTEMPERATUR

Die maximal zulässige Betriebstemperatur beträgt 80°C.

Die Temperaturänderung im Zylinderinneren bestimmt die Veränderung des Ladedrucks: eine Zunahme von 1°C entspricht einer Druckzunahme von 0,33%.

## HINWEISE

Damit die Stickstoffzylinder auf Langzeit in bester Weise arbeiten können, sollte der Benutzer folgende Vorsichtsmaßnahmen beim Einsatz beachten:

- Einschritte oder Beschädigungen des Körpers oder Kolbenstange sind zu vermeiden.
- Der Kolbenstangenschutz darf nur kurz vor Benutzung entfernt werden, um Beschädigung der Oberfläche zu vermeiden.
- Die Zylinder können nur mit Stickstoff N<sub>2</sub> gefüllt werden.
- Bei Auffüllung muss die Kolbenstange vollständig ausgezogen sein.
- Nicht mit Druck über 15MPa aufladen.

## KENNZEICHNUNG

Alle Stickstoffzylinder haben eine Markierung auf dem Körper, wie in der ISO Norm vorgesehen ist, und fallen unter die PED Richtlinie der Europäischen Union (97/23/CE).

## GARANTIE

Die Garantie dauert 1 Jahr ab Inbetriebnahme des Zylinders. VEP Automation ist für den Fall verantwortlich, dass das Produkt nicht den garantierten Herstellung- und Güteigenschaften entspricht. Der Hersteller haftet weder bei Schäden, die durch unsachgemäßen Gebrauch oder Nichtbeachtung der Anweisungen des Katalogs verursacht wurden, noch bei eventueller Veränderung der Zylinder, falscher Befestigung, Verwendung von Nicht-Originalersatzteilen, falscher Berechnung der Anlage oder Auswahl der Abmessungen, Stößen, Rissen oder Zeichen auf der Kolbenstange, welche den Betrieb oder die Druckdichtheit beeinträchtigen könnten.

## AUSWAHL DER ZYLINDER

Für die Auswahl des Zylindertyps muss berücksichtigt werden, dass die Druckzunahme in der Verdichtungsphase der Kolbenstange je nach gewählter Zylinderart um 50 bis 60% variieren kann. Zum Beispiel erreicht ein Zylinder AR 15, mit einem Nutzhub von 155 mm, bei Aufladung mit einem Druck von 15MPa, in geschlossener Stellung einen Druck von ca. 23,5MPa. Die abgegebene Kraft variiert von 1500 daN bis 2400 daN (Daten des Diagramms).

**Die Zylinderauswahl kann in folgender Weise erfolgen:**

- Überprüfen, wieviel Zylinder im verfügbaren Bereich angeordnet werden können;
- Die für jeden Zylinder notwendige Ladung, mit einem Zuschlag von 10%, sowohl bei Öffnung als Verschluss des Zylinders selbst, in daN und dann den notwendigen Hub bestimmen;
- Den Zylinder nach den verschiedenen Ladedrücken (Daten im Diagramm) auf Grund der gewünschten Ladung und Hub sowie der entwickelten Nominalkraft auswählen.

**Die Zylinder können autonom oder als System arbeiten.**

- Sie können einzeln geladen und dann in den vorgesehenen Aufnahmen positioniert oder mit den betreffenden Flanschen befestigt werden.
- Sie können durch eine Kontrolltafel und ein Rohrnetz mit Anschlüssen miteinander in der Form verbunden werden.
- Sie können mit einem Ausgleichsbehälter verbunden werden, falls während der Arbeit eine weniger starke Kraftzunahme notwendig ist.



## SYMBOLES / SYMBOLS / SYMBOLE

**S Max (mm)**

COURSE DU VÉRIN  
Cylinder stroke  
Zylinderhub



AUGMENTATION DE PRESSION  
AVEC L'AUGMENTATION DE LA  
TEMPÉRATURE  
Pressure increase with temperature  
increase  
Druckzunahme bei Temperaturanstieg

**La (mm)**

LONGUEUR DU VÉRIN OUVERT  
Open cylinder length  
Länge des offenen Zylinders

**Vmax  
(m/min)**

VITESSE MAX DE  
FONCTIONNEMENT VÉRIN  
Maximum working speed in m/minutes  
Höchstgeschwindigkeit des Zylinders bei  
der Arbeit

**Lb (mm)**

LONGUEUR DU VÉRIN FERMÉ  
Closed cylinder length  
Länge des geschlossenen Zylinders

**Vo (litre)**

VOLUME INITIAL  
Initial volume  
Anfangsvolumen Volumen inicial

**Fo (daN)**

FORCE INITIALE  
Initial force  
Anfangskraft

**A (cm<sup>2</sup>)**

SECTION DE LA TIGE DU VÉRIN  
Cylinder rod section  
Querschnitt der Kolbenstange

**P (MPa)**

FORCE FINALE  
Final force  
Endkraft

**Kg**

POIDS DU VÉRIN  
Cylinder weight  
Gewicht des Zylinders

**P max (MPa)**

PRESSION  
Pressure  
Druck

**ISO**

SELON NORME ISO 11901/  
CNOMO E.24.54.815.N./VDI 3003  
According to ISO Std. 11901/  
CNOMO E.24.54.815.N./VDI 3003  
gemäß Norm ISO 11901/  
CNOMO E.24.54.815.N./VDI 3003

**P max (MPa)**

PRESSION MAXIMUM DE  
CHARGEMENT  
Maximum charging pressure  
Maximaler Ladedruck

**Pmin (MPa)**

PRESSION MINIMUM DE  
CHARGEMENT  
Minimum charging pressure  
minimaler Ladedruck



**max (c°)**

TEMPÉRATURE MAX DE  
FONCTIONNEMENT  
Maximum operating temperature  
Maximale Betriebstemperatur

## SPÉCIFICATIONS DE MONTAGE CSR

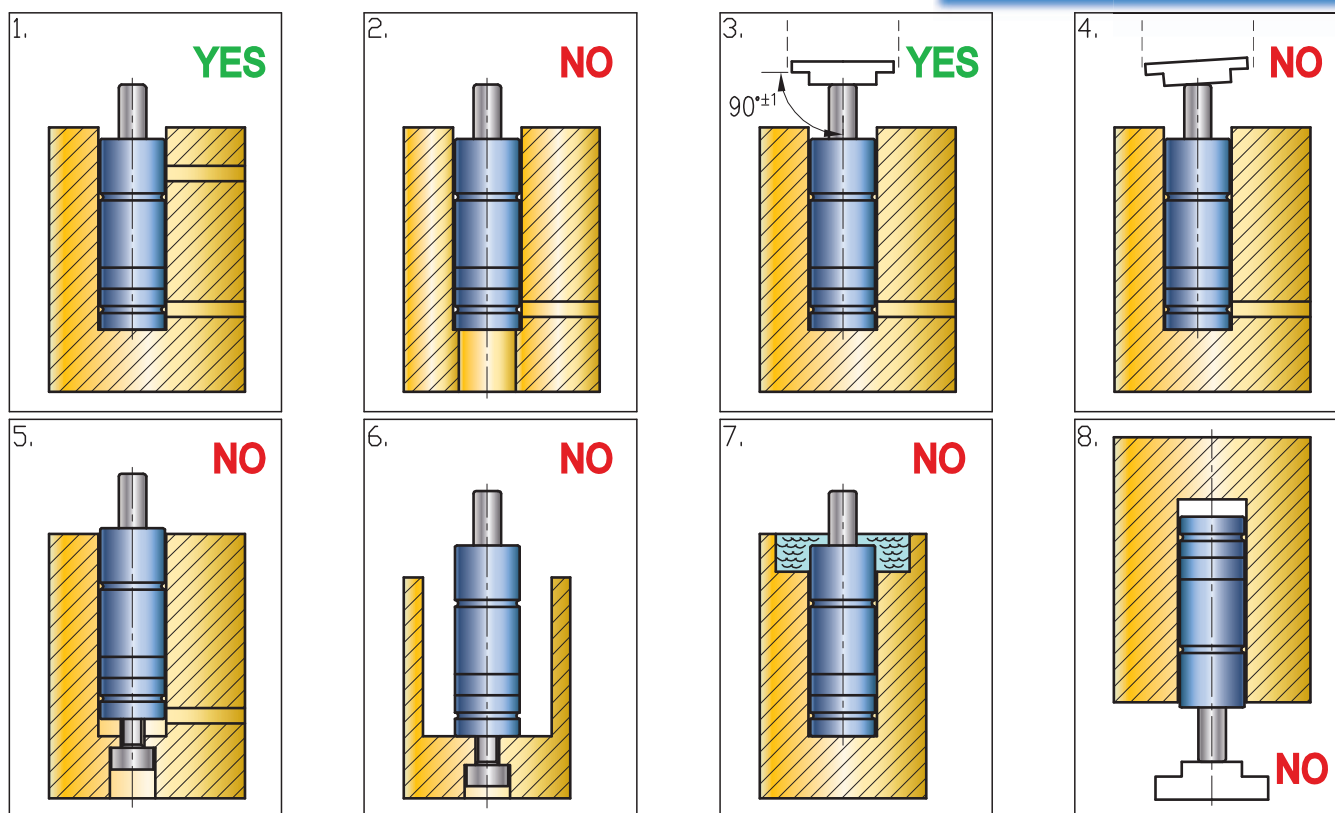
ASSEMBLY SPECIFICATIONS CSR  
MONTAGEVORSCHRIFTEN CSRVEP  
AUTOMATION

- F** 1. Créer des orifices d'évent ; 2. Dans les orifices à double diamètre ne pas appuyer le corps sur les coins ; 3&4. Travailler toujours avec le plan de travail perpendiculaire au vérin; 5. Vérifier que le vérin ne travaille pas sur les vis ; 6. Créer des logements appropriés au diamètre du vérin; 7. Ne pas laisser stagner les liquides émulsif dans la partie supérieure du vérin ; 8. Fixer le vérin dans toutes conditions de travail.
- GB** 1. Create holes to let out the emulsions ; 2. In the holes with double diameter do not rest the body on the edges ; 3&4. Always work with the working surface at right angle to the cylinder ; 5. Make sure that the cylinder does not work on the screws ; 6. Create appropriate housings for the cylinder diameter ; 7. Do not let the emulsion fluids stagnate in the top part of the cylinder ; 8. Restrain the cylinder in any work condition.
- D** 1. Bohrungen für Emulsionsabfluss vorsehen ; 2. In Bohrungen mit doppeltem Durchmesser den Körper nicht auf die Kanten stellen ; 3&4. Stets mit rechtwinklig zum Zylinder stehender Arbeitsfläche arbeiten ; 5. Kontrollieren dass der Zylinder nicht auf den Schrauben arbeitet ; 6. Dem Zylinderdurchmesser angepasste Sitze herstellen ; 7. Emulsionsflüssigkeiten dürfen nicht im oberen Zylinder teil stagnieren; 8. Den Zylinder bei jeglicher Arbeitsbedingung befestigen.

## INFORMATIONS GÉNÉRALES

GENERAL INFORMATION  
ALLGEMEINE INFORMATIONEN

- F** Ne pas utiliser la course au-delà de 90% de la course max. Précharger le vérin au moins 1mm, si cela est possible. Éviter toutes interventions ou tous endommagement des corps et des tiges. Avant l'utilisation ne pas enlever le filet de protection des tiges. Les vérins sont chargés avec gaz azote (N<sub>2</sub>), ne pas utiliser absolument aucun autre type de gaz. Le chargement du gaz doit s'effectuer lorsque la tige est entièrement tirée. Quand le vérin est usé, il doit être remplacé car il n'est pas possible de le réparer.
- GB** Do not use the stroke beyond 90% of the max. stroke. Precharge the cylinders at least 1mm, when possible. Avoid operations or damage on the bodies and rods. Do not remove the protective net from the rods before use. The cylinders are charged with nitrogen gas (N<sub>2</sub>), absolutely never use other types of gas. Gas charging must be carried out with the rod completely pulled out. When the cylinder is worn it must be replaced completely, repair is not possible.
- D** Nicht mehr als 90% des max. Hubs verwenden. Den Zylinder wenigstens 1 mm vorladen, soweit möglich sind Einschritte oder Beschädigung für Körper und Kolbenstange zu vermeiden: Das Schutznetz der Kolbenstange erst kurz vor Verwendung entfernen. Die Zylinder sind mit Stickstoff (N<sub>2</sub>) geladen, Es darf absolut kein anderer Gastyp verwendet werden. Die Auffüllung mit Gas kann nur bei vollständig ausgezogener Kolbenstange erfolgen. Bei Abnutzung muss der Zylinder vollständig ersetzt werden, eine Reparatur ist nicht möglich.

# RESSORT A GAZ CSR 19

GAS SPRING CSR 19  
GASDRUCKFEDERN CSR 19

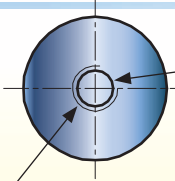

Orifice de chargement/déchargement et de fixation  
Charging and fastening hole  
Befüllungs und Befestigungsbohrung

Taraudage M6 Profondeur 5 mm  
Hole M6 by 5 mm deep  
Bohrung M6 5 mm tief

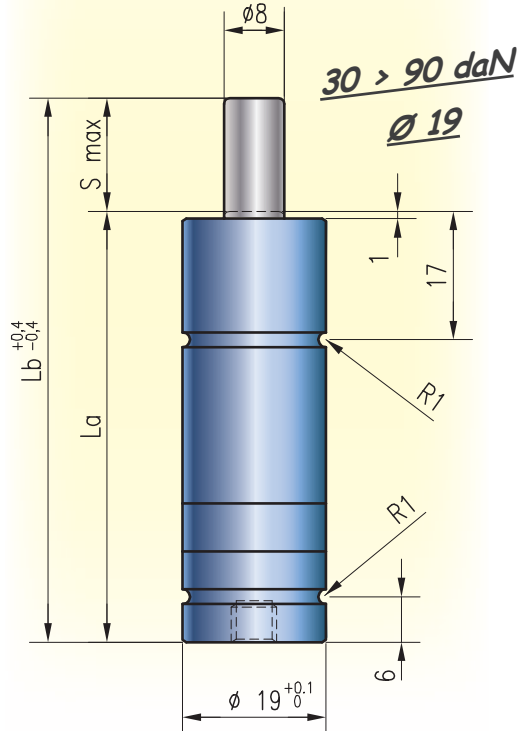

P max	P min	🌡️ max
18 MPa/2610 psi	4,5 MPa/653 psi	80 C°/176 °F

🌡️	A (cm²)	V max
0,0367/1°C	0,502 (cm2)	35m/min - 23 in/sec

Code	Pression (initiale) Mpa / psi	Force (initiale) daN / lb.	Force (finale) daN / lb.
VERT / Green	6 Mpa / 870 psi	30 daN / 66 lb.	40 daN / 88 lb.
BLEU / Blue	10 Mpa / 1450 psi	50 daN / 110 lb.	67 daN / 148 lb.
ROUGE / Red	14 Mpa / 2030 psi	70 daN / 154 lb.	94 daN / 207 lb.
JAUNE / Yellow	18 Mpa / 2610 psi	90 daN / 198 lb.	120 daN / 264 lb.
NOIR / Black ***	-	-	-

\*\*\* Sur demande : Version adaptable pouvant être chargée à une pression variable entre 4,5 et 18 MPa.  
 \*\*\* On request : Adaptable version that can be charged at a variable pressure between 4.5 and 18 MPa.  
 \*\*\* Auf anfrage : Anpassbare Version, die mit einem verschiedenen Druck von 4,5 bis 18 MPa befüllt werden kann.  
 \*\*\* REF. 270 CSR=19 S=10 mm F=x daN 270-19-10-0

\*\* Exécution selon la norme VDI  
 \*\* Manufacturing to VDI std  
 \*\* Ausführung nach Norm VDI

REF. 270 CSR=19 S=50 mm F=30 daN  
 REF. 270 CSR=19 S=63 mm F=70 daN VDI=V

270-19-50-30  
 270-19-63-70-V

\* sur demande / on request / auf Anfrage

Code	S max	La	Lb	VDI	CSR	S max mm	F (Force initiale / Initial force / Anfangskraft)				
							30 daN	50 daN	70 daN	90 daN	*** daN
CSR 19 - 7	mm 7 in. 0,27	49	56	-	19	7	*	*	*	*	*
CSR 19 - 10	mm 10 in. 0,39	52	62	-		10	*	*	*	*	*
CSR 19 - 15	mm 15 in. 0,59	57	72	-		15	*	*	*	*	*
CSR 19 - 25	mm 25 in. 0,98	67	92	-		25	*	*	*	*	*
CSR 19 - 38	mm 38 in. 1,5	80	118	-		38	*	*	*	*	*
CSR 19 - 50	mm 50 in. 1,97	92	142	-		50	*	*	*	*	*
CSR 19 - 63	mm 63 in. 2,48	106	169	-		63	*	*	*	*	*
CSR 19 - 63.1**	mm 63 in. 2,48	109	172	V **		63	*	*	*	*	*
CSR 19 - 80	mm 80 in. 3,15	122	202	-		80	*	*	*	*	*
CSR 19 - 80.1**	mm 80 in. 3,15	125	205	V **		80	*	*	*	*	*

280



### FIXATION POUR RESSORT A GAZ CSR 19

MOUNT FOR GAS SPRING CSR 19  
BEFESTIGUNGEN FÜR GASDRUCKFEDERN CSR 19

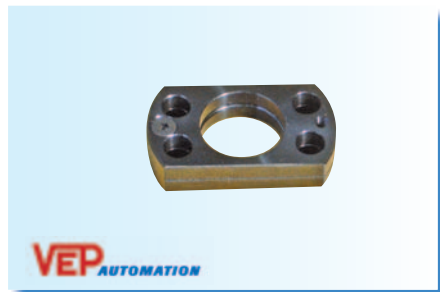

CSR 19

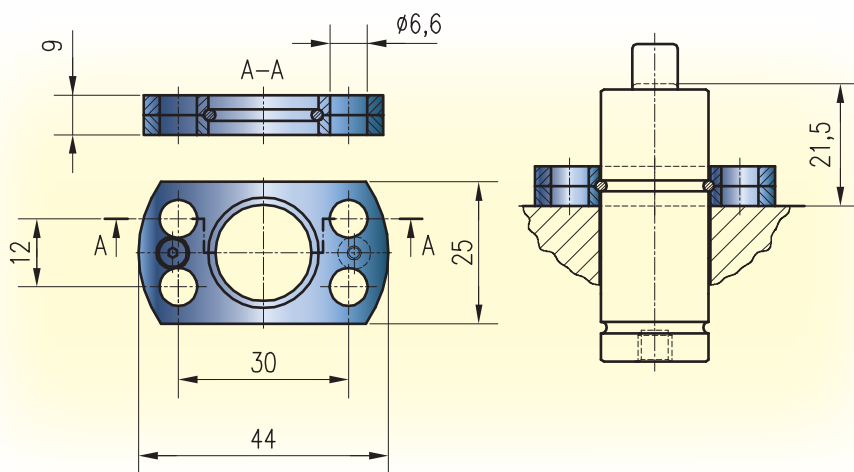

REF. 280 CSR=19



280-19

\* sur demande / on request / auf Anfrage

CSR	REF. 280
19	*

281



### FIXATION POUR RESSORT A GAZ CSR 19

MOUNT FOR GAS SPRING CSR 19  
BEFESTIGUNGEN FÜR GASDRUCKFEDERN CSR 19

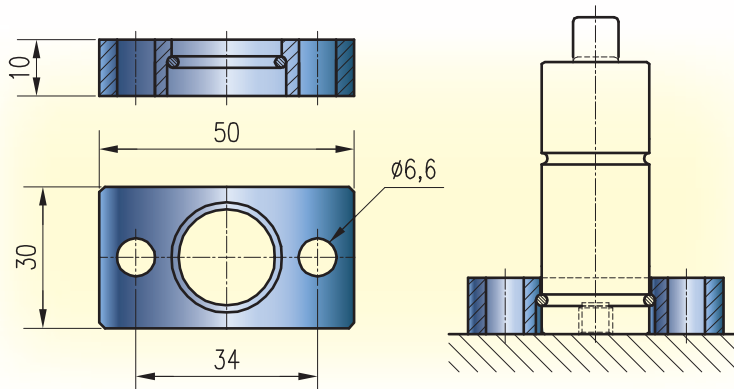
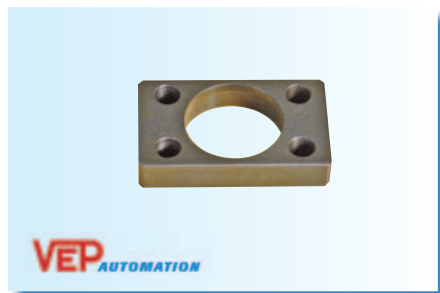

REF. 281 CSR=19



281-19

\* sur demande / on request / auf Anfrage

CSR	REF. 281
19	*

# RESSORT A GAZ CSR 25

GAS SPRING CSR 25  
GASDRUCKFEDERN CSR 25

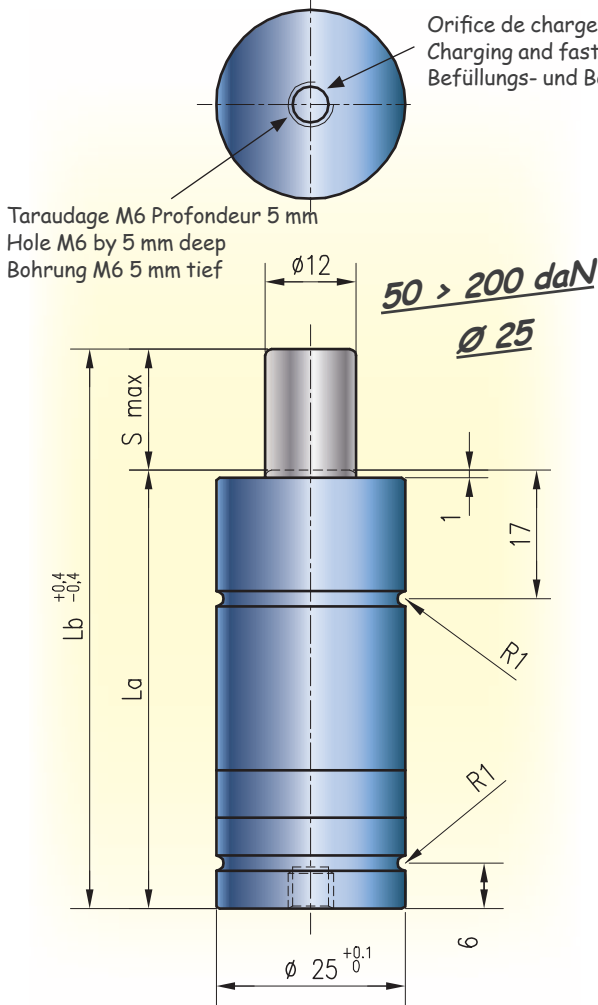

P max	P min	max
18 MPa/2610 psi	4,5 MPa/653 psi	80 C°/176 °F

	A (cm²)	V max
0,0367/1°C	1,13 (cm2)	35m/min - 23 in/sec

Code	Pression (initiale) Mpa / psi	Force (initiale) daN / lb.	Force (finale) daN / lb.
VERT / Green	4,5 Mpa / 653 psi	50 daN / 110 lb.	80 daN / 176 lb.
BLEU / Blue	9 Mpa / 1305 psi	100 daN / 220 lb.	165 daN / 364 lb.
ROUGE / Red	13,5 Mpa / 1958	150 daN / 330 lb.	245 daN / 540 lb.
JAUNE / Yellow	18 Mpa / 2610 psi	200 daN / 441 lb.	325 daN / 716 lb.
NOIR / Black **	-	-	-

\*\* Sur demande : Version adaptable pouvant être chargée à une pression variable entre 4,5 et 18 MPa.  
 \*\* On request : Adaptable version that can be charged at a variable pressure between 4,5 and 18 MPa.  
 \*\* Auf anfrage : Anpassbare Version, die mit einem verschiedenen Druck von 4,5 bis 18 MPa befüllt werden kann.  
 \*\* REF. 270 CSR=25 S=100 mm F=x daN 270-25-100-0

REF. 270 CSR=25 S=16 mm F=150 daN

270-25-16-150

\* sur demande / on request / auf Anfrage

Code	S max	La	Lb	CSR	S max mm	F (Force initiale / Initial force / Anfangskraft)				
						50 daN	100 daN	150 daN	200 daN	** daN
CSR 25 - 10	mm 10 in. 0,39	52 2,04	62 2,44	25	10	*	*	*	*	*
CSR 25 - 13	mm 13 in. 0,51	55 2,16	68 2,67		13	*	*	*	*	*
CSR 25 - 16	mm 16 in. 0,63	58 2,28	74 3		16	*	*	*	*	*
CSR 25 - 25	mm 25 in. 0,98	67 2,64	92 3,62		25	*	*	*	*	*
CSR 25 - 38	mm 38 in. 1,5	80 3,15	118 4,64		38	*	*	*	*	*
CSR 25 - 50	mm 50 in. 1,97	92 3,62	142 5,6		50	*	*	*	*	*
CSR 25 - 63	mm 63 in. 2,48	108 4,13	171 6,65		63	*	*	*	*	*
CSR 25 - 80	mm 80 in. 3,15	125 4,92	205 8,07		80	*	*	*	*	*
CSR 25 - 100	mm 100 in. 3,94	145 5,71	245 9,64		100	*	*	*	*	*
CSR 25 - 125	mm 125 in. 4,92	170 6,69	295 11,61		125	*	*	*	*	*

280



**FIXATION POUR RESSORT A GAZ CSR 25**

MOUNT FOR GAS SPRING CSR 25  
BEFESTIGUNGEN FÜR GASDRUCKFEDERN CSR 25



CSR 25

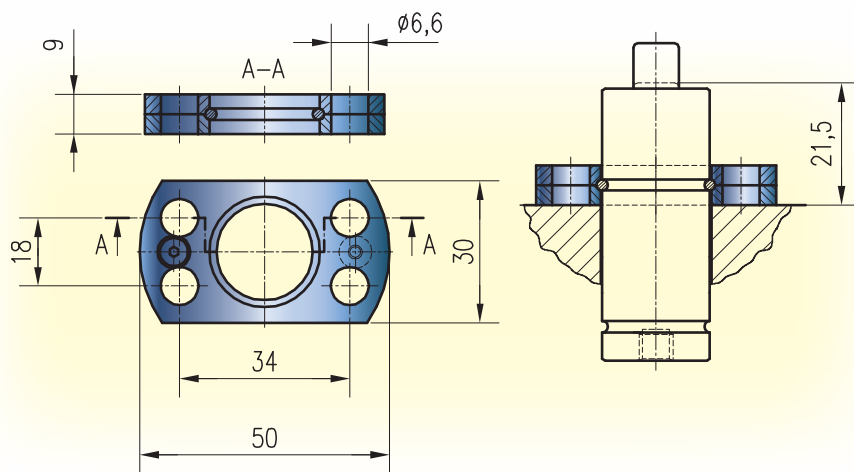

REF. 280 CSR=25



280-25

\* sur demande / on request / auf Anfrage

CSR	REF. 280
25	*

281



**FIXATION POUR RESSORT A GAZ CSR 25**

MOUNT FOR GAS SPRING CSR 25  
BEFESTIGUNGEN FÜR GASDRUCKFEDERN CSR 25

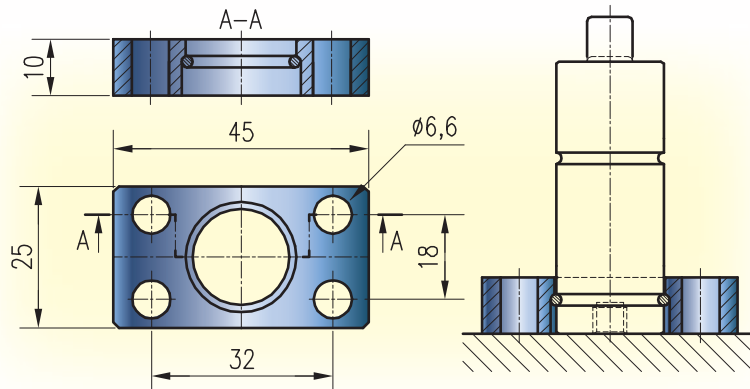
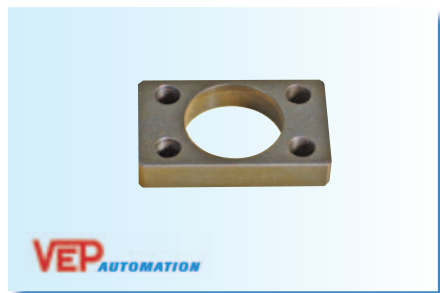

REF. 281 CSR=25



281-25

\* sur demande / on request / auf Anfrage

CSR	REF. 281
25	*



RESSORT A GAZ KC 3

GAS SPRING KC 3  
GASDRUCKFEDERN KC 3



KC 3

300 daN  
Ø 32

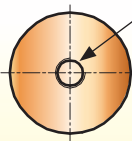

Taroudage M8 Profondeur 4 mm  
Hole M8 by 4 mm deep  
Bohrung M8 4 mm tief

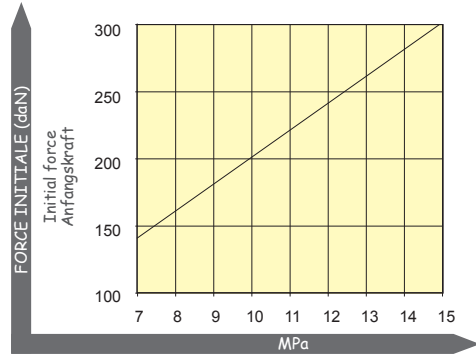

Orifice de chargement/déchargement M6  
Charging hole M6  
Befüllungsbohrung M6

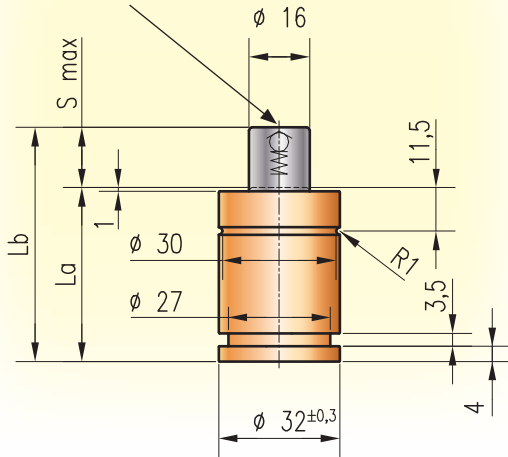

Force disponible lorsque la course de la tige varie.  
Pression de chargement: 15 MPa.  
Force available at different lengths of stroke.  
Charging pressure: 15 MPa.  
Bei Veränderung des Kolbenstangenhubs verfügbare Kraft.  
Ladedruck: 15 MPa.

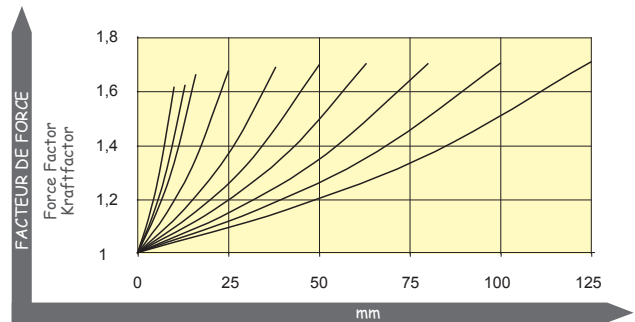

P max	P min	max	max	V max
15 Mpa	2 MPa	80 C°	0,0367/1°C	12 m/min

REF. 271 KC-3 S=50

271-3-50

\* sur demande / on request / auf Anfrage

Code	La mm	Lb mm	Fo daN	F daN	P MPa	V l	A cm <sup>2</sup>	Poids Kg	KC	S (max) mm	REF. 271
KC 3-10	40	50	300 (±5%)	486	15	0,005	2,009	0,11	3	10	*
KC 3-13	43	56		488		0,006		0,12		13	*
KC 3-16	46	62		500		0,008		0,13		16	*
KC 3-25	55	80		503		0,012		0,14		25	*
KC 3-38	68	106		508		0,018		0,16		38	*
KC 3-50	80	130		511		0,024		0,18		50	*
KC 3-63	93	156		512		0,03		0,21		63	*
KC 3-80	110	190		512		0,039		0,24		80	*
KC 3-100	130	230		513		0,048		0,28		100	*
KC 3-125	155	280		514		0,061		0,33		125	*

# RESSORT A GAZ KC 5

GAS SPRING KC 5  
GASDRUCKFEDERN KC 5



**500 daN**  
**Ø 38**

Taraudage M8 Profondeur 4 mm  
Hole M8 by 4 mm deep  
Bohrung M8 4 mm tief

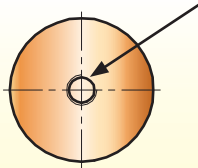

Orifice de chargement/déchargement M6  
Charging hole M6  
Befüllungsbohrung M6

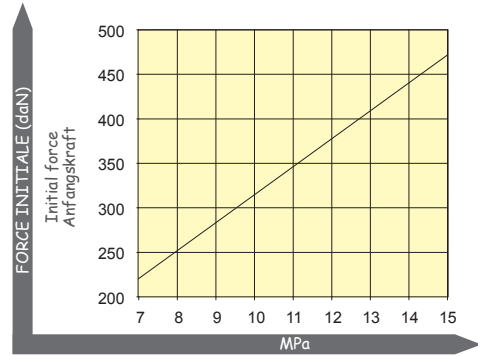
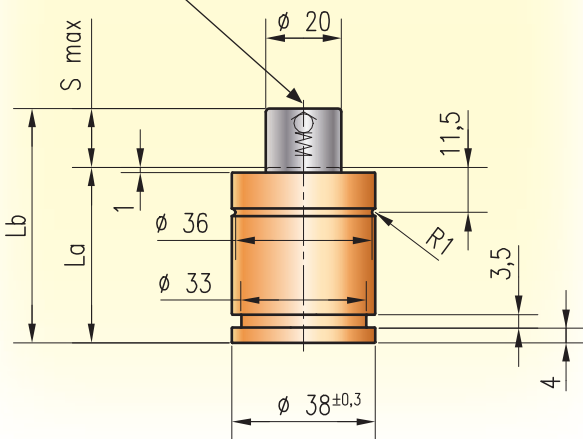

Force disponible lorsque la course de la tige varie.  
Pression de chargement: 15 MPa.  
Force available at different lengths of stroke.  
Charging pressure: 15 MPa.  
Bei Veränderung des Kolbenstangenhubs verfügbare Kraft.  
Ladedruck: 15 MPa.

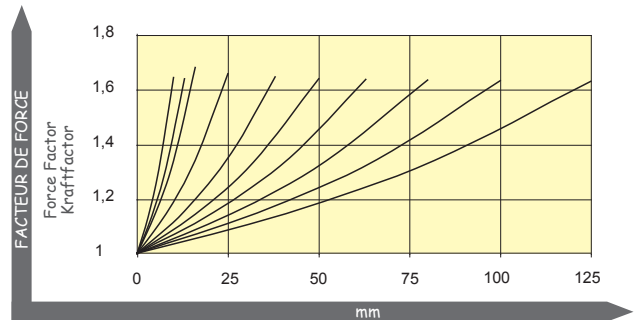

P max	P min	max		V max
15 Mpa	2 MPa	80 C°	0,0367/1°C	12 m/min

REF. 271 KC-5 S=63

271-5-63

\* sur demande / on request / auf Anfrage

Code	La mm	Lb mm	Fo daN	F daN	P MPa	V l	A cm <sup>2</sup>	Poids Kg	KC	S (max) mm	REF. 271
KC 5-10	40	50	500 (±5%)	773	15	0,008	3,14	0,25	5	10	*
KC 5-13	43	56		771		0,01		0,26			
KC 5-16	46	62		790		0,012		0,27			
KC 5-25	55	80		780		0,019		0,31			
KC 5-38	68	106		774		0,03		0,6			
KC 5-50	80	130		771		0,04		0,4			
KC 5-63	93	156		769		0,05		0,45			
KC 5-80	110	190		768		0,064		0,52			
KC 5-100	130	230		767		0,081		0,6			
KC 5-125	155	280		766		0,101		0,7		125	*

# RESSORT A GAZ KC 7

GAS SPRING KC 7  
GASDRUCKFEDERN KC 7



**700 daN**  
**Ø 45**

2 Taraudages M8 Prof. 4 mm  
2 Holes M8 by 4 mm deep  
2 Bohrungen M8 4mm tief

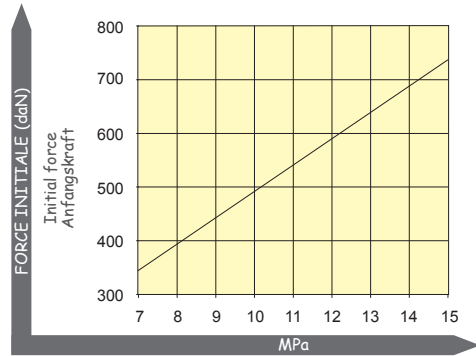
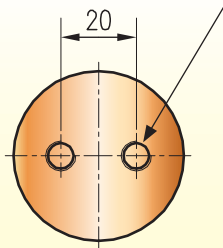

Orifice de chargement/déchargement M6  
Charging hole M6  
Befüllungsbohrung M6

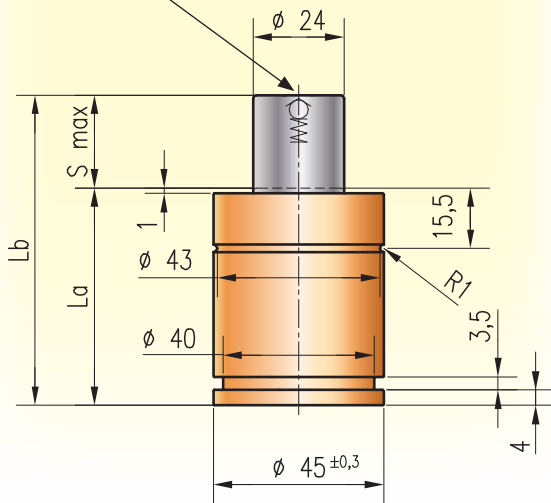

Force disponible lorsque la course de la tige varie.  
Pression de chargement: 15 MPa.  
Force available at different lengths of stroke.  
Charging pressure: 15 MPa.  
Bei Veränderung des Kolbenstangenhubs verfügbare Kraft.  
Ladedruck: 15 MPa.

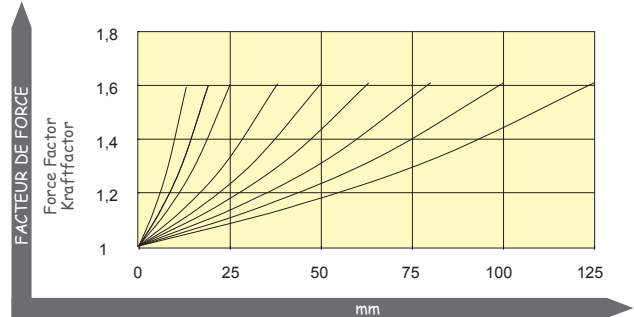

P max	P min	max		V max
15 Mpa	2 MPa	80 C°	0,0367/1°C	12 m/min

REF. 271 KC=7 S=63

271-7-63

\* sur demande / on request / auf Anfrage

Code	La mm	Lb mm	Fo daN	F daN	P MPa	V l	A cm <sup>2</sup>	Poids Kg	KC	S (max) mm	REF. 271
KC 7-13	45	58	700 (±5%)	1078	15	0,015	4,521	0,39	7	13	*
KC 7-19	51	70		1082		0,022		0,41			
KC 7-25	57	82		1084		0,03		0,45			
KC 7-38	70	108		1087		0,045		0,53			
KC 7-50	82	132		1088		0,06		0,61			
KC 7-63	95	158		1088		0,075		0,69			
KC 7-80	112	192		1089		0,095		0,8			
KC 7-100	132	232		1089		0,119		0,93			
KC 7-125	157	282		1090		0,149		1,09			

# RESSORT A GAZ KC 10

GAS SPRING KC 10  
GASDRUCKFEDERN KC 10



Orifice de chargement/déchargement M6  
Charging hole M6  
Befüllungsbohrung M6

2 Taraudages M8 Prof. 6 mm  
2 Holes M8 by 6 mm deep  
2 Bohrungen M8 6 mm tief

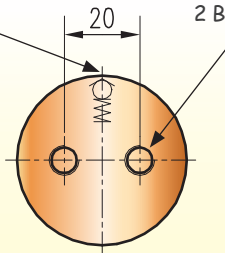

**1000 daN**  
**Ø 50**

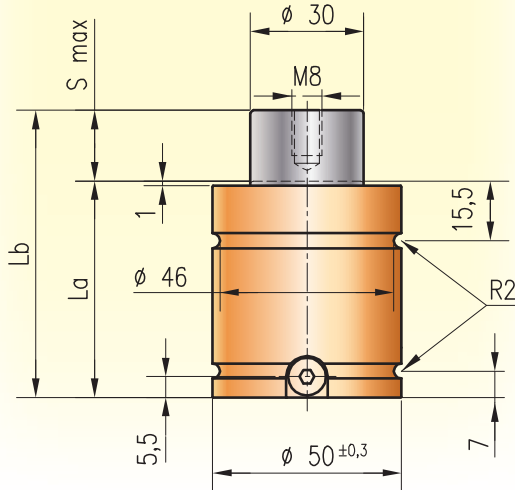
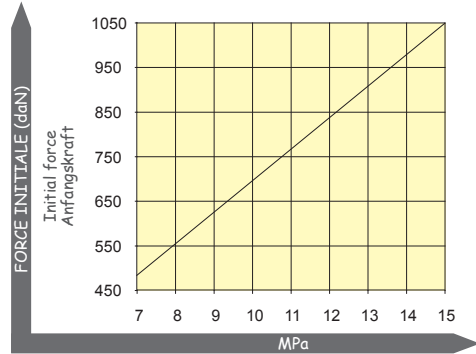

Force disponible lorsque la course de la tige varie.  
Pression de chargement: 15 MPa.

Force available at different lengths of stroke.

Charging pressure: 15 MPa.

Bei Veränderung des Kolbenstangenhubs verfügbare Kraft.  
Ladedruck: 15 MPa.

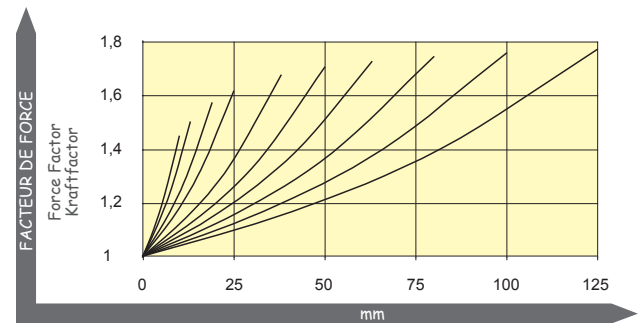

P max	P min	max		V max
15 Mpa	2 MPa	80 C°	0,0367/1°C	12 m/min

REF. 271 KC=10 S=25

271-10-25

\* sur demande / on request / auf Anfrage

Code	La mm	Lb mm	Fo daN	F daN	P MPa	V l	A cm <sup>2</sup>	Poids Kg	KC	S (max) mm	REF. 271
KC 10-10	48	58	1000 (±5%)	1531	15	0,022	7,065	0,49	10	10	*
KC 10-13	51	64		1587		0,027		0,52			
KC 10-19	57	76		1661		0,037		0,56			
KC 10-25	63	88		1709		0,046		0,61			
KC 10-38	76	114		1770		0,066		0,71			
KC 10-50	88	138		1802		0,085		0,81			
KC 10-63	101	164		1825		0,106		0,91			
KC 10-80	118	196		1844		0,132		1,05			
KC 10-100	138	238		1859		0,164		1,2			
KC 10-125	163	288		1872		0,203		1,4			

# RESSORT A GAZ KC 15

GAS SPRING KC 15  
GASDRUCKFEDERN KC 15



KC 15

Orifice de chargement/déchargement M6  
Charging hole M6  
Befüllungsbohrung M6

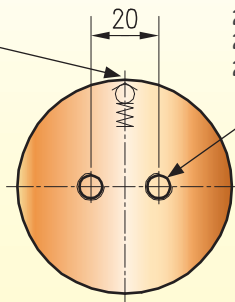

2 Taraudages M8 Prof. 5 mm  
2 Holes M8 by 5 mm deep  
2 Bohrungen M8 5mm tief

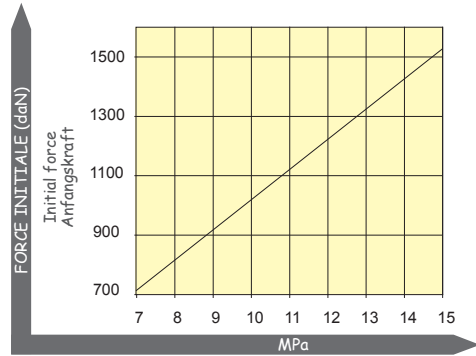

**1500 daN**  
**Ø 63**

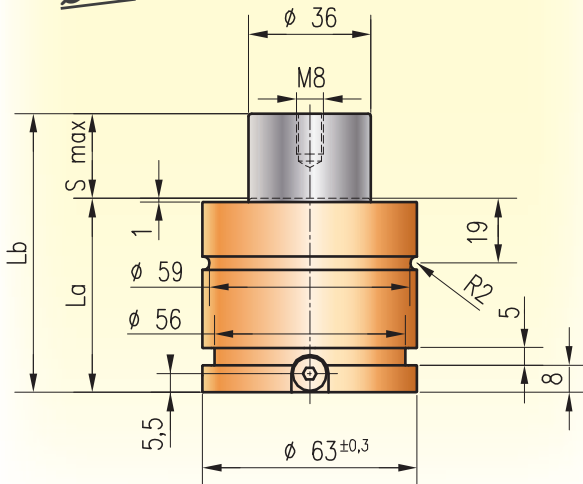

Force disponible lorsque la course de la tige varie.  
Pression de chargement: 15 MPa.  
Force available at different lengths of stroke.  
Charging pressure: 15 MPa.  
Bei Veränderung des Kolbenstangenhubs verfügbare Kraft.  
Ladedruck: 15 MPa.

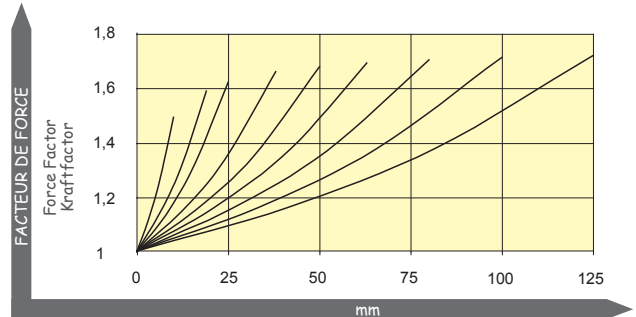

P max	P min	max		V max
15 Mpa	2 MPa	80 C°	0,0367/1°C	12 m/min

REF. 271 KC=15 S=25

271-15-25

\* sur demande / on request / auf Anfrage

Code	La mm	Lb mm	Fo daN	F daN	P MPa	V l	A cm <sup>2</sup>	Poids Kg	KC	S (max) mm	REF. 271
KC 15-10	54	64	1500 (±5%)	2273	15	0,03	10,17	0,9	15	10	*
KC 15-19	63	82		0,052		1		19		*	
KC 15-25	69	94		0,066		1,1		25		*	
KC 15-38	82	120		0,097		1,2		38		*	
KC 15-50	94	144		0,126		1,3		50		*	
KC 15-63	107	170		0,156		1,4		63		*	
KC 15-80	124	204		0,197		1,4		80		*	
KC 15-100	144	244		0,244		1,9		100		*	
KC 15-125	169	294		0,304		2,2		125		*	

# RESSORT A GAZ KC 24

GAS SPRING KC 24  
GASDRUCKFEDERN KC 24



Orifice de chargement/déchargement M6  
Charging hole M6  
Befüllungsbohrung M6

4 Taraudages M8 Prof. 5 mm  
4 Holes M8 by 5 mm deep  
4 Bohrungen M8 5mm tief

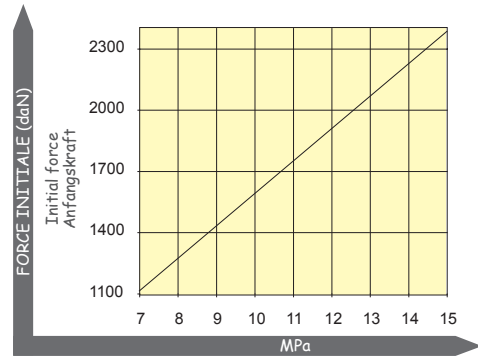
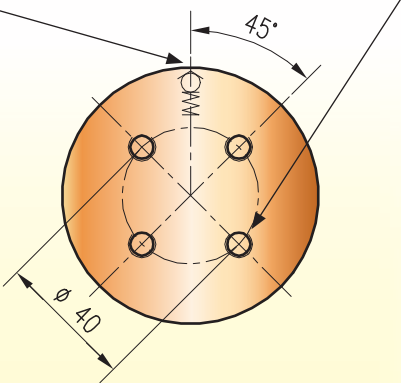

**2400 daN**  
**Ø 75**

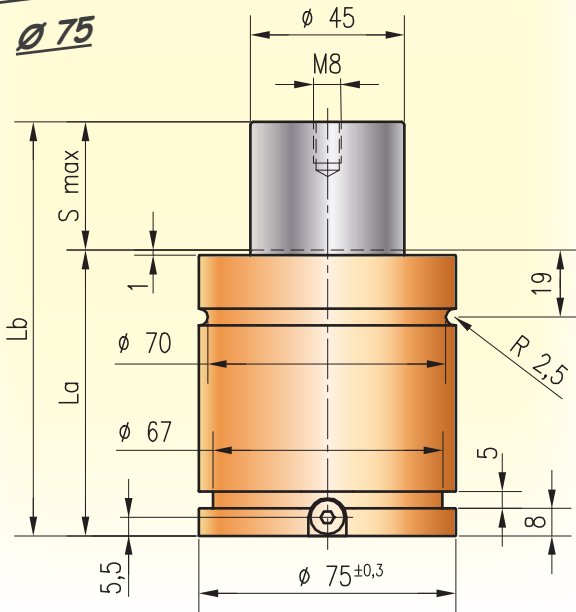

Force disponible lorsque la course de la tige varie.  
Pression de chargement: 15 MPa.  
Force available at different lengths of stroke.  
Charging pressure: 15 MPa.  
Bei Veränderung des Kolbenstangenhubs verfügbare Kraft.  
Ladedruck: 15 MPa.

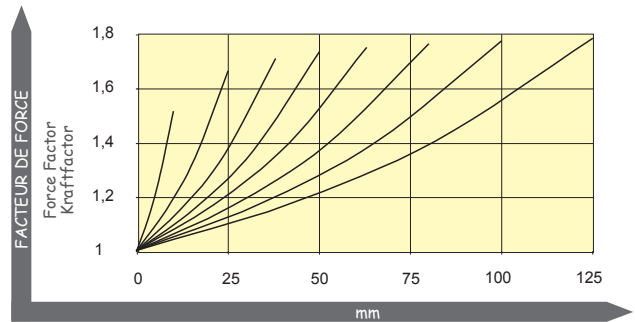

P max	P min	max	max	V max
15 Mpa	2 MPa	80 C°	0,0367/1°C	12 m/min

REF. 271 KC=24 S=100

271-24-100

\* sur demande / on request / auf Anfrage

Code	La mm	Lb mm	Fo daN	F daN	P MPa	V l	A cm <sup>2</sup>	Poids Kg	KC	S (max) mm	REF. 271
KC 24-10	55	65	2400 (±5%)	3603	15	0,004	15,89	1,1	24	10	*
KC 24-25	70	95		3957		0,1		1,54		*	
KC 24-38	83	121		4069		0,14		1,71		*	
KC 24-50	95	145		4126		0,18		1,89		*	
KC 24-63	108	171		4165		0,23		2,09		*	
KC 24-80	125	205		4199		0,29		2,35		*	
KC 24-100	145	245		4224		0,36		2,66		*	
KC 24-125	170	295		4245		0,45		3,04		*	

# RESSORT A GAZ KC 42

GAS SPRING KC 42  
GASDRUCKFEDERN KC 42



KC 42

Orifice de chargement/déchargement M6  
Charging hole M6  
Befüllungsbohrung M6

4 Taraudages M8 Prof. 8 mm  
4 Holes M8 by 8 mm deep  
4 Bohrungen M8 8 mm tief

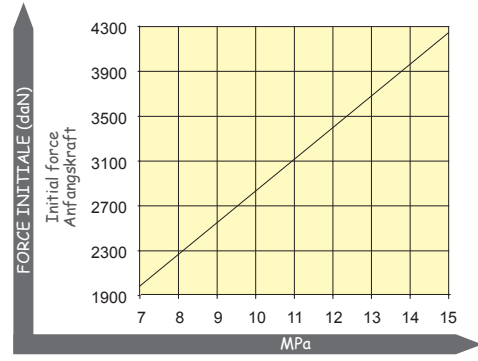
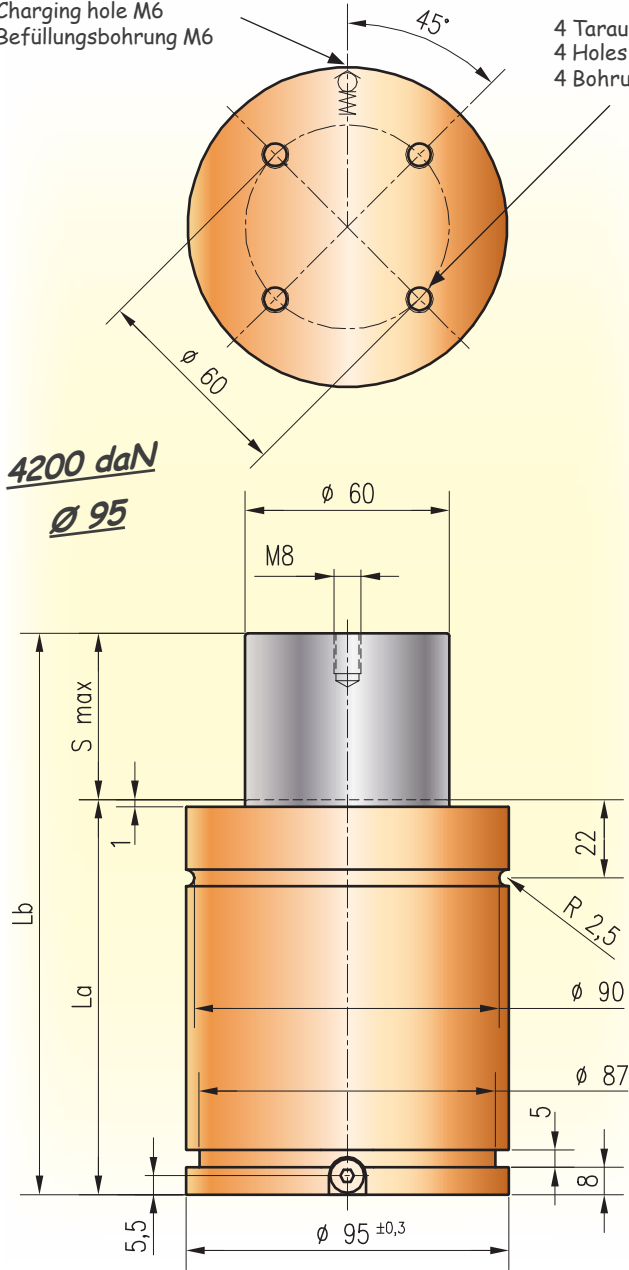

Force disponible lorsque la course de la tige varie.  
Pression de chargement: 15 MPa.  
Force available at different lengths of stroke.  
Charging pressure: 15 MPa.  
Bei Veränderung des Kolbenstangenhubs verfügbare Kraft.  
Ladedruck: 15 MPa.

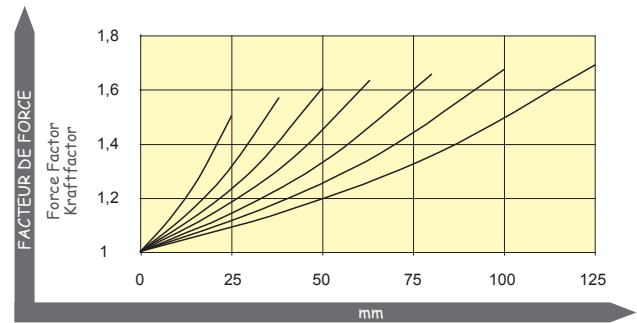

P max	P min	max	max	V max
15 Mpa	2 MPa	80 C°	0,0367/1°C	12 m/min

REF. 271 KC=42 S=100

271-42-100

\* sur demande / on request / auf Anfrage

Code	La mm	Lb mm	Fo daN	F daN	P MPa	V l	A cm <sup>2</sup>	Poids Kg	KC	S (max) mm	REF. 271
KC 42-25	90	115	4200 (±5%)	6358	15	0,21	28,26	2,9	42	25	*
KC 42-38	103	141		6639		0,29		3,2		38	*
KC 42-50	115	165		6796		0,37		3,5		50	*
KC 42-63	128	191		6909		0,46		3,8		63	*
KC 42-80	145	225		7010		0,57		4,4		80	*
KC 42-100	165	265		7090		0,7		4,9		100	*
KC 42-125	190	315		7157		0,86		5,4		125	*

# RESSORT A GAZ KC 66

GAS SPRING KC 66  
GASDRUCKFEDERN KC 66

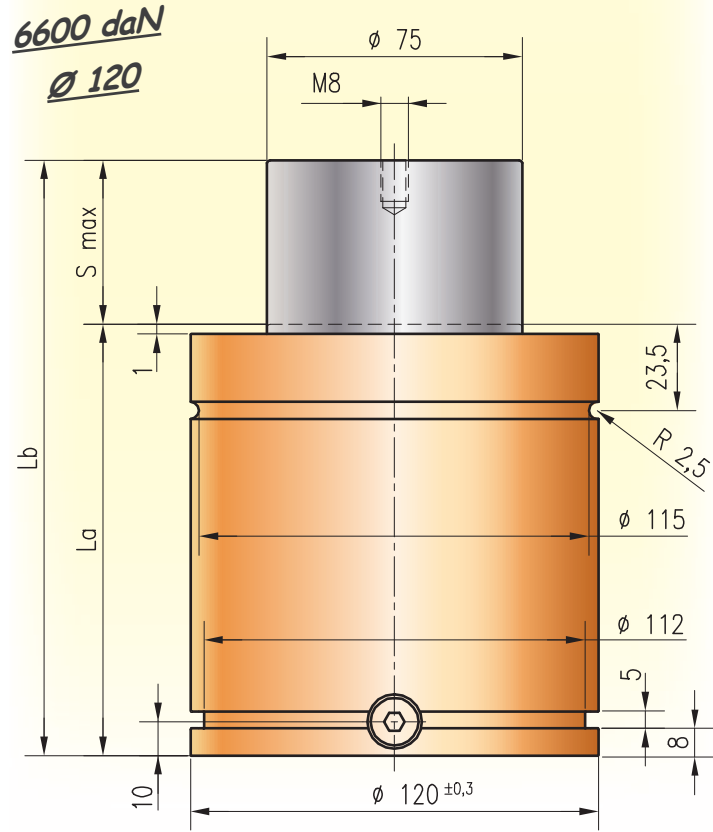
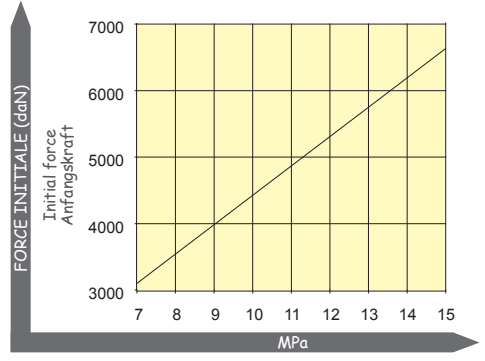
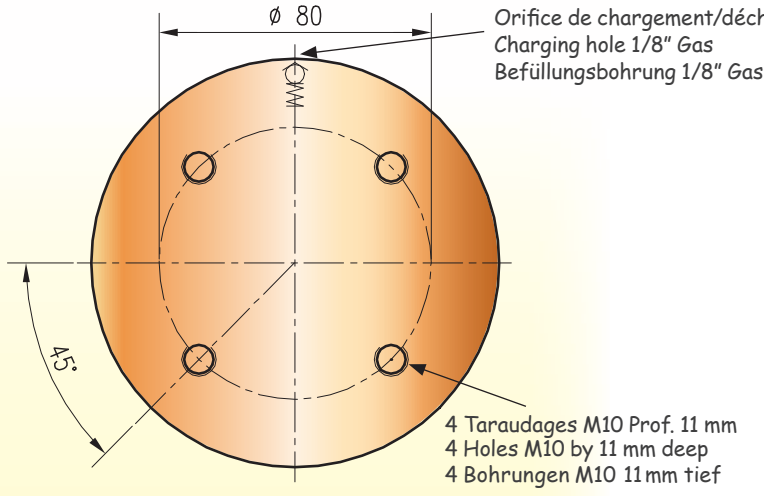

Force disponible lorsque la course de la tige varie.  
Pression de chargement: 15 MPa.  
Force available at different lengths of stroke.  
Charging pressure: 15 MPa.  
Bei Veränderung des Kolbenstangenhubs verfügbare Kraft.  
Ladedruck: 15 MPa.

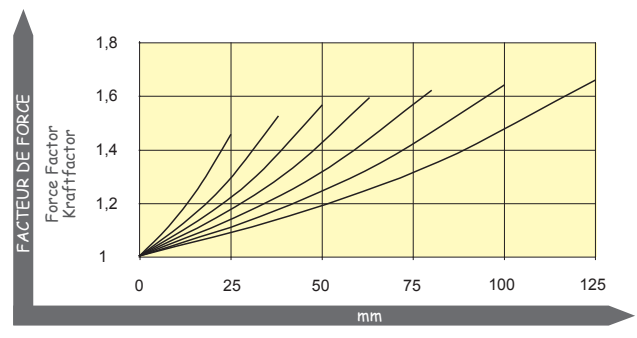

P max	P min	🌡️ max	🕒	V max
15 Mpa	2 MPa	80 C°	0,0367/1°C	12 m/min

REF. 271 KC=66 S=38

271-66-38

\* sur demande / on request / auf Anfrage

Code	La mm	Lb mm	Fo daN	F daN	P MPa	V l	A cm²	Poids Kg	KC	S (max) mm	REF. 271
KC 66-25	100	125	6600 (±5%)	9617	15	0,35	44,15	5,3	66	25	*
KC 66-38	113	151		10075		0,48		5,8		38	*
KC 66-50	125	175		10336		0,61		6,2		50	*
KC 66-63	138	201		10530		0,74		6,8		63	*
KC 66-80	155	235		10704		0,92		7,5		80	*
KC 66-100	175	275		10843		1,13		8,3		100	*
KC 66-125	200	325		10961		1,39		9,2		125	*

# RESSORT A GAZ SR 10

GAS SPRING SR 10  
GASDRUCKFEDERN SR 10



SR 10

2 Taraudages M6 Prof. 6 mm  
2 Holes M6 by 6 mm deep  
2 Bohrungen M6 6 mm tief

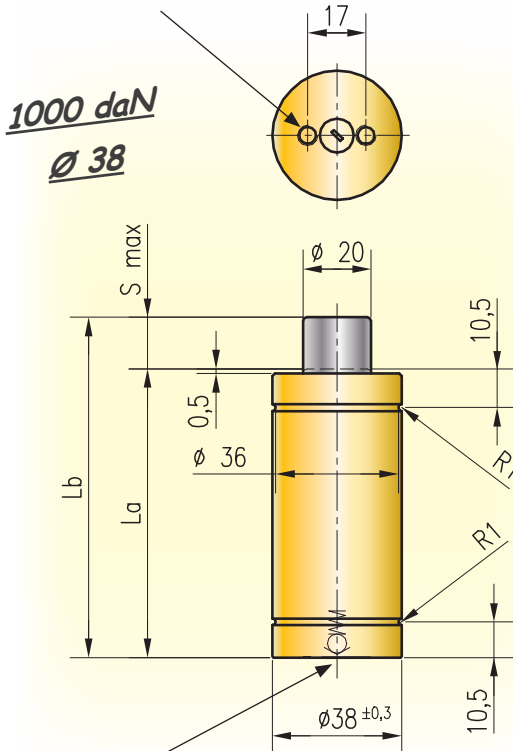

Orifice de chargement/déchargement M6  
Charging hole M6  
Befüllungsbohrung M6

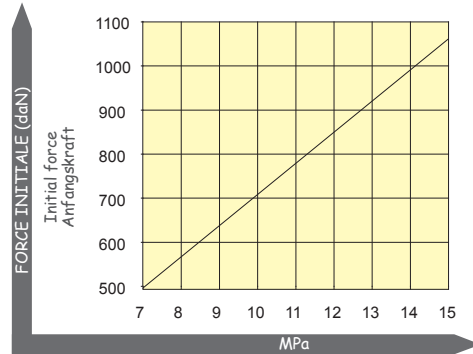

Force disponible lorsque la course de la tige varie.  
Pression de chargement: 15 MPa.  
Force available at different lengths of stroke.  
Charging pressure: 15 MPa.  
Bei Veränderung des Kolbenstangenhubs verfügbare Kraft.  
Ladedruck: 15 MPa.

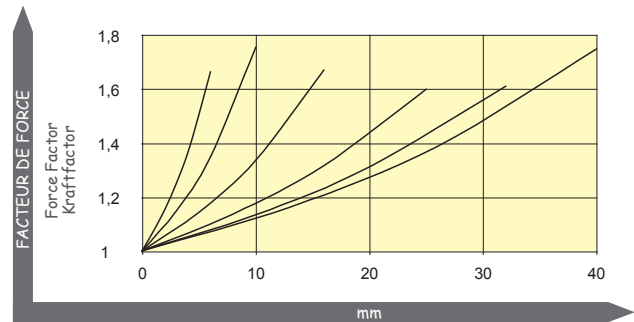

P max	P min	max	max	V max
15 Mpa	2 MPa	80 C°	0,0367/1°C	12 m/min

REF. 272 SR=10 S=32

272-10-32

\* sur demande / on request / auf Anfrage

Code	La mm	Lb mm	Fo daN	F daN	P MPa	V l	A cm <sup>2</sup>	Poids Kg	SR	S (max) mm	REF. 272
SR 10-6	55	61	1000 (±5%)	1759	15	0,01	7,065	0,3	10	6	*
SR 10-10	68	78		1855		0,016		0,4		10	*
SR 10-16	84	100		1766		0,028		0,5		10	*
SR 10-25	110	135		1690		0,047		0,6		10	*
SR 10-32	127	159		1702		0,059		0,7		10	*
SR 10-40	135	175		1849		0,066		0,8		10	*

# RESSORT A GAZ SR 18

GAS SPRING SR 18  
GASDRUCKFEDERN SR 18



2 Taraudages M6 Prof. 6 mm  
2 Holes M6 by 6 mm deep  
2 Bohrungen M6 6 mm tief

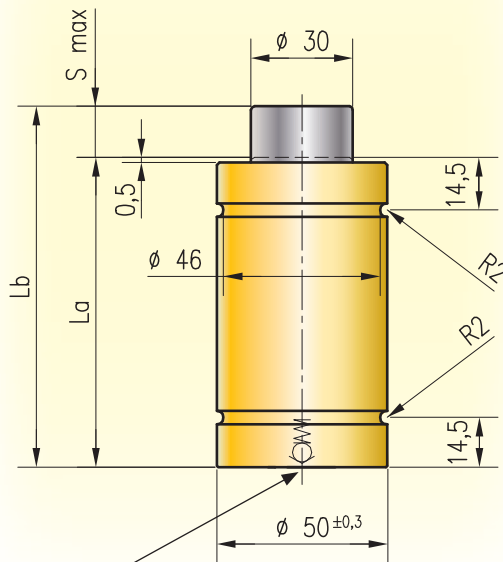
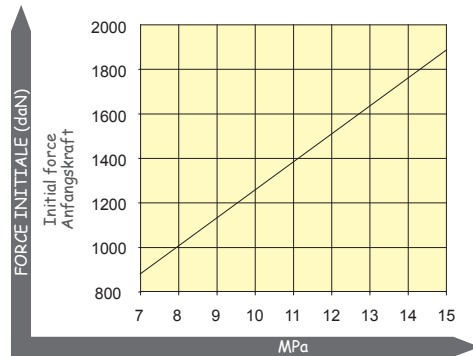
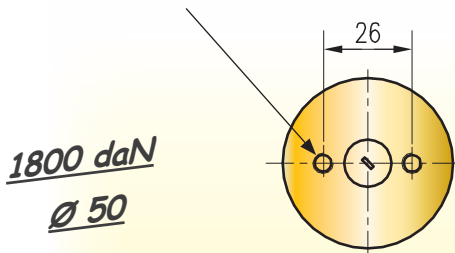

Force disponible lorsque la course de la tige varie.  
Pression de chargement: 15 MPa.  
Force available at different lengths of stroke.  
Charging pressure: 15 MPa.  
Bei Veränderung des Kolbenstangenhubs verfügbare Kraft.  
Ladedruck: 15 MPa.

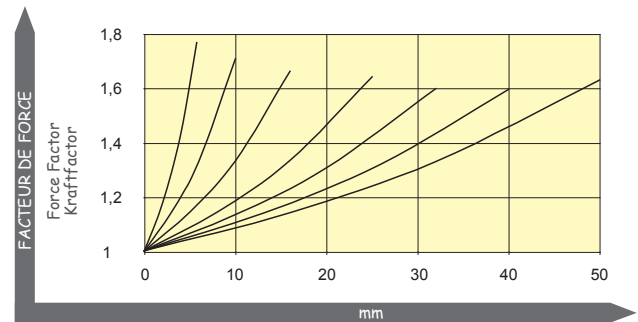

Orifice de chargement/déchargement 1/8" Gaz  
Charging hole 1/8" Gas  
Befüllungsbohrung 1/8" Gas

P max	P min	max	max	V max
15 Mpa	2 MPa	80 C°	0,0367/1°C	12 m/min

REF. 272 SR=18 S=32

272-18-32

\* sur demande / on request / auf Anfrage

Code	La mm	Lb mm	Fo daN	F daN	P MPa	V l	A cm <sup>2</sup>	Poids Kg	SR	S (max) mm	REF. 272
SR 18-6	60	66	1800 (±5%)	3422	15	0,016	12,56	0,6	18	6	*
SR 18-10	70	80		3214		0,03		0,7		10	*
SR 18-16	90	106		3128		0,05		0,8		16	*
SR 18-25	110	135		3089		0,08		1		25	*
SR 18-32	130	162		3007		0,107		1,2		32	*
SR 18-40	150	190		3001		0,134		1,4		40	*
SR 18-50	170	220		3065		0,162		1,6		50	*

# RESSORT A GAZ SR 30

GAS SPRING SR 30  
GASDRUCKFEDERN SR 30



SR 30

2 Taraudages M8 Prof. 9 mm  
2 Holes M8 by 9 mm deep  
2 Bohrungen M8 9 mm tief

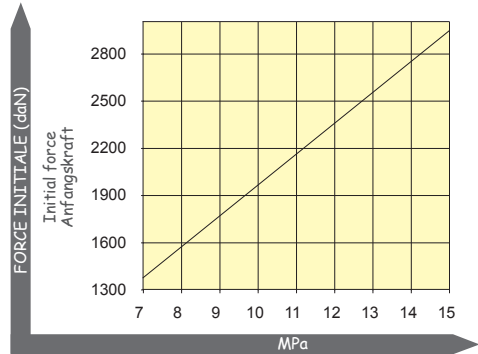
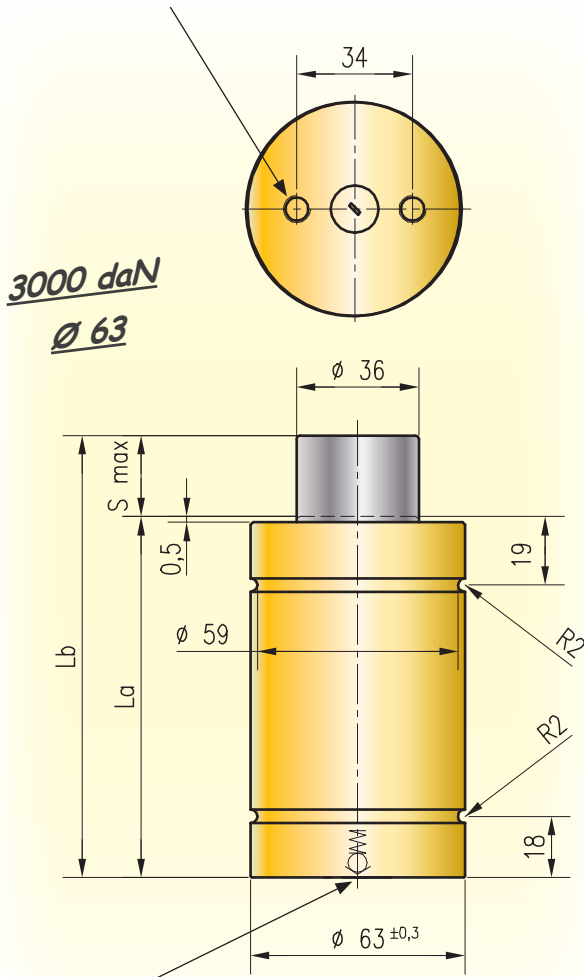

Force disponible lorsque la course de la tige varie.  
Pression de chargement: 15 MPa.  
Force available at different lengths of stroke.  
Charging pressure: 15 MPa.  
Bei Veränderung des Kolbenstangenhubs verfügbare Kraft.  
Ladedruck: 15 MPa.

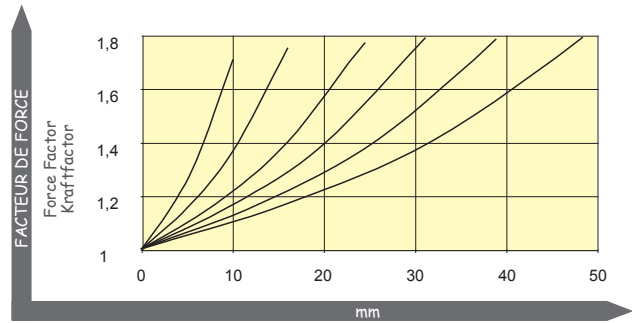

Orifice de chargement/déchargement 1/8" Gaz  
Charging hole 1/8" Gas  
Befüllungsbohrung 1/8" Gas

P max	P min	max	max	V max
15 Mpa	2 MPa	80 C°	0,0367/1°C	12 m/min

REF. 272 SR=30 S=40

272-30-40

\* sur demande / on request / auf Anfrage

Code	La mm	Lb mm	Fo daN	F daN	P MPa	V l	A cm <sup>2</sup>	Poids Kg	SR	S (max) mm	REF. 272
SR 30-10	75	85	3000 (±5%)	4900	15	0,6	19,62	1,1	30	10	*
SR 30-16	87	103		5148		0,073		1,3		16	*
SR 30-25	105	130		5300		0,1		1,5		25	*
SR 30-32	118	150		5364		0,139		1,6		32	*
SR 30-40	135	175		5337		0,175		1,8		40	*
SR 30-50	155	205		5364		0,217		2,1		50	*



RESSORT A GAZ SR 43

GAS SPRING SR 43  
GASDRUCKFEDERN SR 43



4 Taraudages M8 Prof. 9 mm  
4 Holes M8 by 9 mm deep  
4 Bohrungen M8 9 mm tief

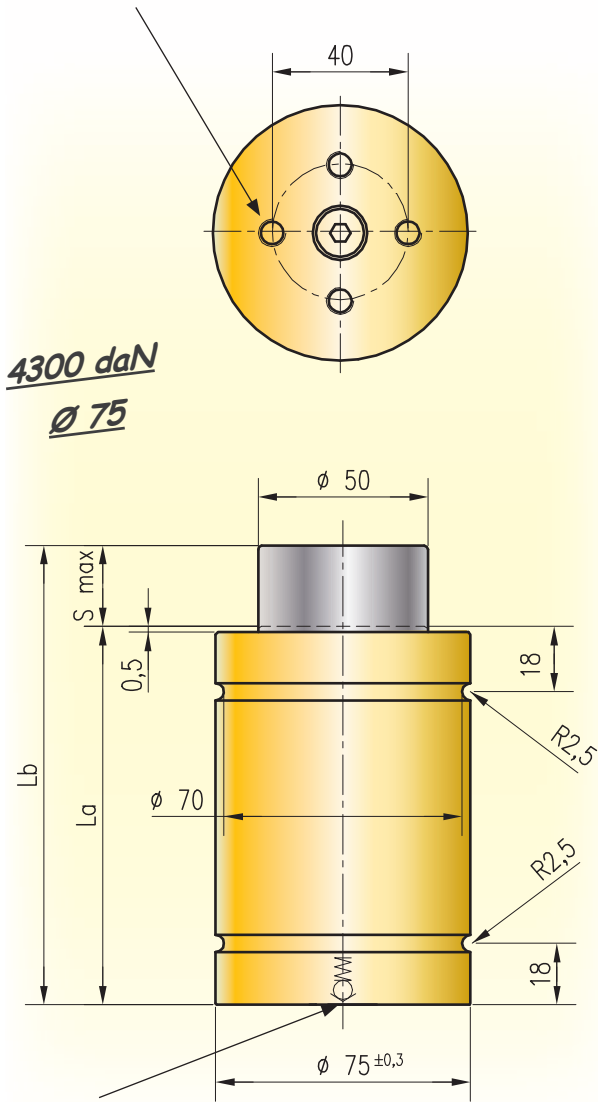

**4300 daN**  
**Ø 75**

Orifice de chargement/déchargement 1/8" Gaz  
Charging hole 1/8" Gas  
Befüllungsbohrung 1/8" Gas

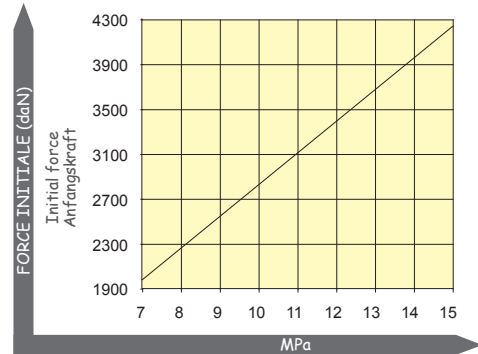

Force disponible lorsque la course de la tige varie.  
Pression de chargement: 15 MPa.  
Force available at different lengths of stroke.  
Charging pressure: 15 MPa.  
Bei Veränderung des Kolbenstangenhubs verfügbare Kraft.  
Ladedruck: 15 MPa.

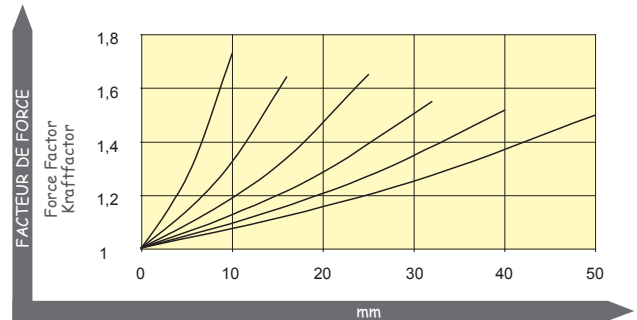

P max	P min	max	max	V max
15 Mpa	2 MPa	80 C°	0,0367/1°C	12 m/min

REF. 272 SR=43 S=10

272-43-10

\* sur demande / on request / auf Anfrage

Code	La mm	Lb mm	Fo daN	F daN	P MPa	V l	A cm <sup>2</sup>	Poids Kg	SR	S (max) mm	REF. 272
SR 43-10	70	80	4300 (±5%)	7305	15	0,067	28,26	1,4	30	10	*
SR 43-16	90	106		6937		0,116		1,7		*	
SR 43-25	110	135		6977		0,179		2		*	
SR 43-32	135	167		6550		0,256		2,4		*	
SR 43-40	160	200		6411		0,333		2,8		*	
SR 43-50	190	240		6341		0,426		3,3		*	

# RESSORT A GAZ SR 75

GAS SPRING SR 75  
GASDRUCKFEDERN SR 75

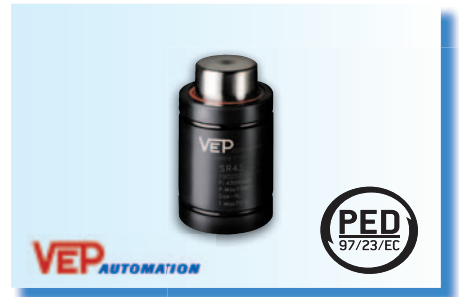

SR 75

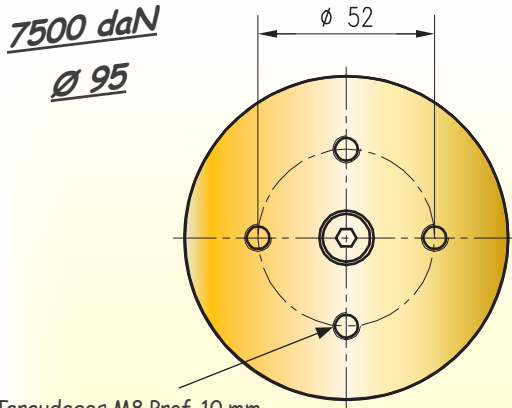

7500 daN  
Ø 95  
4 Taraudages M8 Prof. 10 mm  
4 Holes M8 by 10 mm deep  
4 Bohrungen M8 10 mm tief

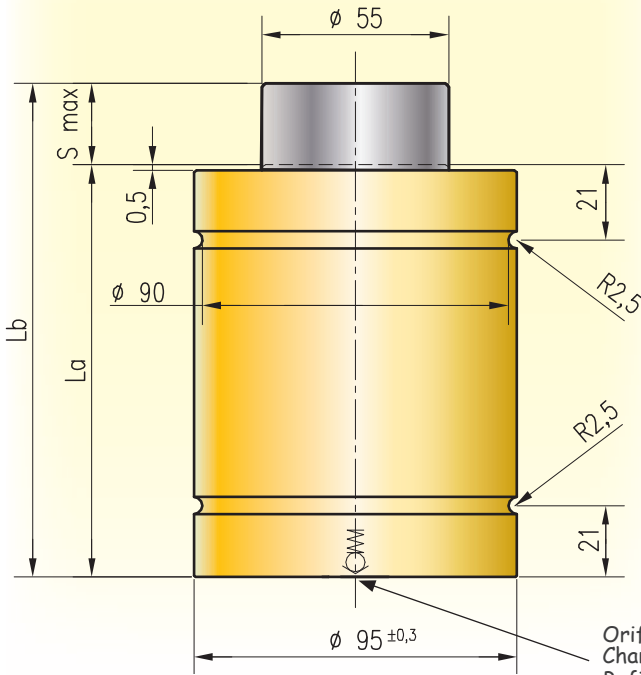
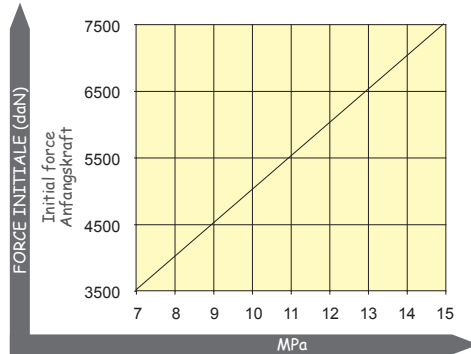

Force disponible lorsque la course de la tige varie.  
Pression de chargement: 15 MPa.  
Force available at different lengths of stroke.  
Charging pressure: 15 MPa.  
Bei Veränderung des Kolbenstangenhubs verfügbare Kraft.  
Ladedruck: 15 MPa.

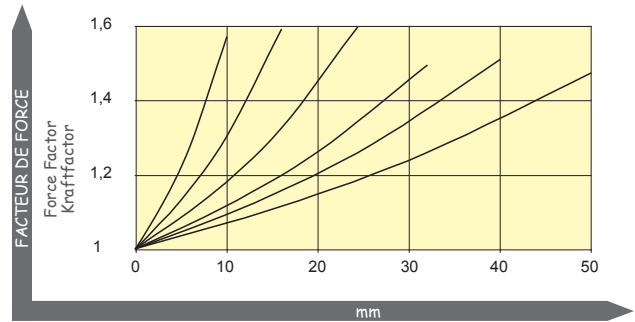

Orifice de chargement/déchargement 1/8" Gaz  
Charging hole 1/8" Gas  
Befüllungsbohrung 1/8" Gas

P max	P min	max	max	V max
15 Mpa	2 MPa	80 C°	0,0367/1°C	12 m/min

REF. 272 SR=75 S=10

272-75-10

\* sur demande / on request / auf Anfrage

Code	La mm	Lb mm	Fo daN	F daN	P MPa	V l	A cm <sup>2</sup>	Poids Kg	SR	S (max) mm	REF. 272
SR 75-10	80	90	7500 (±5%)	11813	15	0,138	50,24	2,8	75	10	*
SR 75-16	100	116		11968		0,217		3,2		16	*
SR 75-25	120	145		12195		0,328		3,7		25	*
SR 75-32	150	182		11245		0,487		4,4		32	*
SR 75-40	170	210		11360		0,596		4,8		40	*
SR 75-50	205	255		11088		0,784		5,6		50	*

# RESSORT A GAZ SR 120

GAS SPRING SR 120  
GASDRUCKFEDERN SR 120

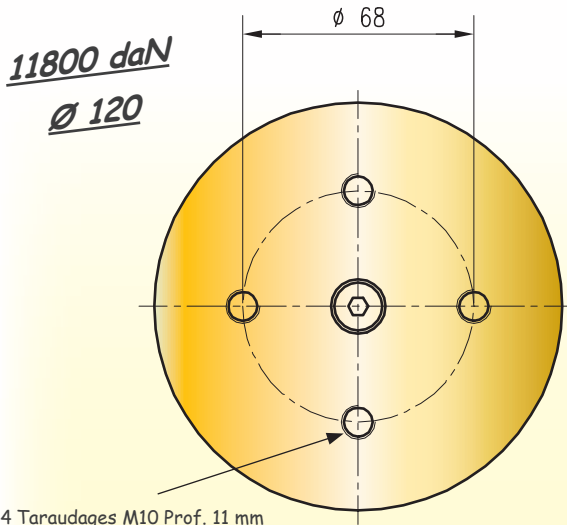

4 Taraudages M10 Prof. 11 mm  
4 Holes M10 by 11 mm deep  
4 Bohrungen M10 11 mm tief

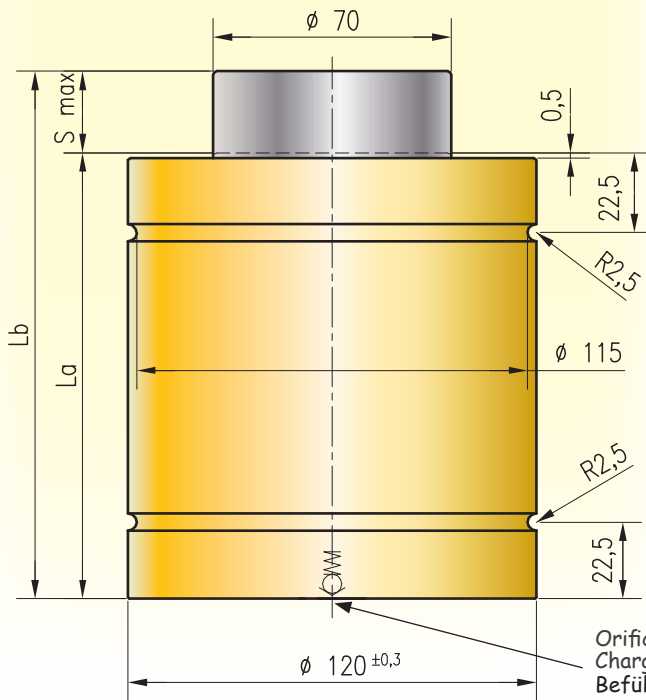
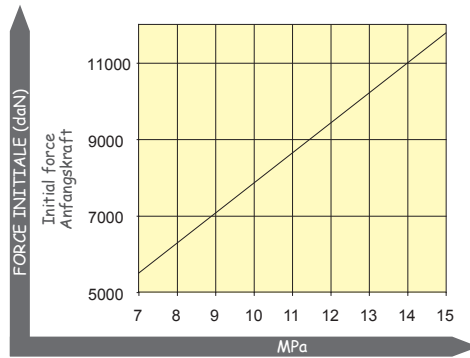

Force disponible lorsque la course de la tige varie.  
Pression de chargement: 15 MPa.  
Force available at different lengths of stroke.  
Charging pressure: 15 MPa.  
Bei Veränderung des Kolbenstangenhubs verfügbare Kraft.  
Ladedruck: 15 MPa.

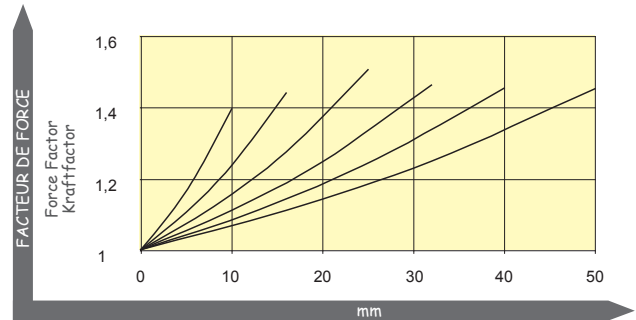

Orifice de chargement/déchargement 1/8" Gaz  
Charging hole 1/8" Gas  
Befüllungsbohrung 1/8" Gas

P max	P min	max	max	V max
15 Mpa	2 MPa	80 C°	0,0367/1°C	12 m/min

REF. 272 SR=120 S=25

272-120-25

\* sur demande / on request / auf Anfrage

Code	La mm	Lb mm	Fo daN	F daN	P MPa	V l	A cm <sup>2</sup>	Poids Kg	SR	S (max) mm	REF. 272
SR 120-10	90	100	11800 (±5%)	16420	15	0,277	78,5	5,4	120	10	*
SR 120-16	110	126		16943		0,411		6		16	*
SR 120-25	130	155		17697		0,586		6,9		25	*
SR 120-32	155	187		17200		0,796		7,8		32	*
SR 120-40	180	220		17099		1,008		8,7		40	*
SR 120-50	210	260		17081		1,236		9,9		50	*

# RESSORT A GAZ SR 170

GAS SPRING SR 170  
GASDRUCKFEDERN SR 170

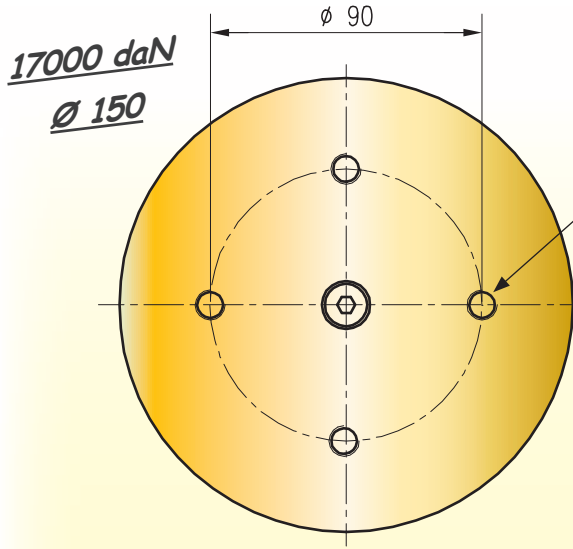

4 Taraudages M10 Prof. 11 mm  
4 Holes M10 by 11 mm deep  
4 Bohrungen M10 11 mm tief

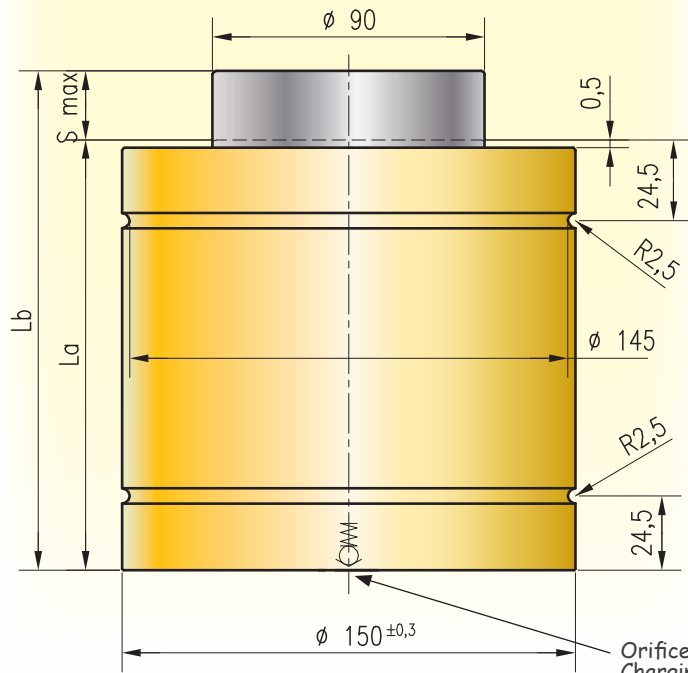
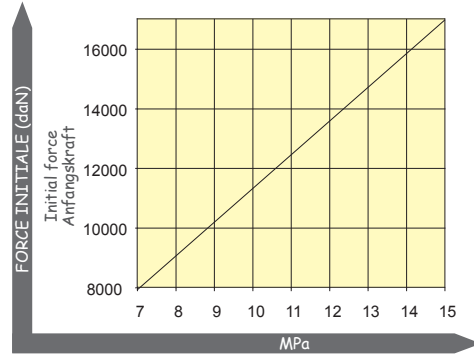

Force disponible lorsque la course de la tige varie.  
Pression de chargement: 15 MPa.  
Force available at different lengths of stroke.  
Charging pressure: 15 MPa.  
Bei Veränderung des Kolbenstangenhubs verfügbare Kraft.  
Ladedruck: 15 MPa.

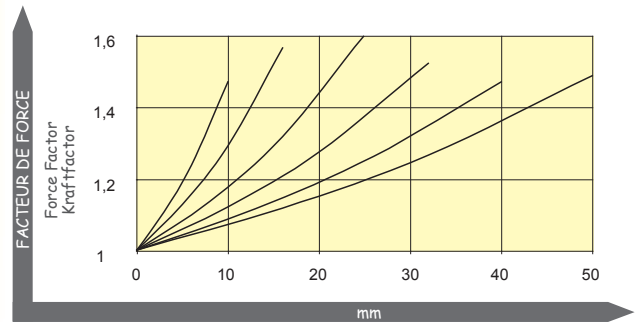

Orifice de chargement/déchargement 1/8" Gaz  
Charging hole 1/8" Gas  
Befüllungsbohrung 1/8" Gas.

P max	P min	max	max	V max
15 Mpa	2 MPa	80 C°	0,0367/1°C	12 m/min

REF. 272 SR=170 S=16

272-170-16

\* sur demande / on request / auf Anfrage

Code	La mm	Lb mm	Fo daN	F daN	P MPa	V l	A cm <sup>2</sup>	Poids Kg	SR	S (max) mm	REF. 272
SR 170-10	100	110	17000 (±5%)	24903	15	0,354	113,04	9,5	170	10	*
SR 170-16	120	136		26530		0,501		10,4		16	*
SR 170-25	140	165		27149		0,752		11,8		25	*
SR 170-32	165	197		25802		1,055		13,3		32	*
SR 170-40	195	235		24903		1,416		15		40	*
SR 170-50	220	270		25200		1,727		16,5		50	*

# RESSORT A GAZ KCR 10

GAS SPRING KCR 10  
GASDRUCKFEDERN KCR 10



**1000 daN**  
**Ø 50**

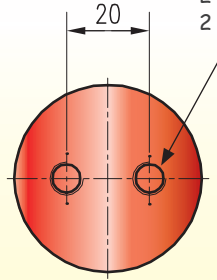

2 Taraudages M8 Prof. 5 mm  
2 Holes M8 by 5 mm deep  
2 Bohrungen M8 5 mm tief

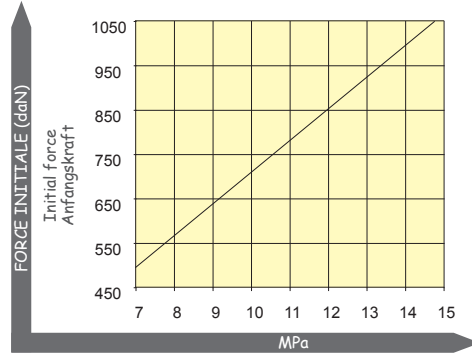

Orifice de chargement/déchargement M6  
Charging hole M6  
Befüllungsbohrung M6

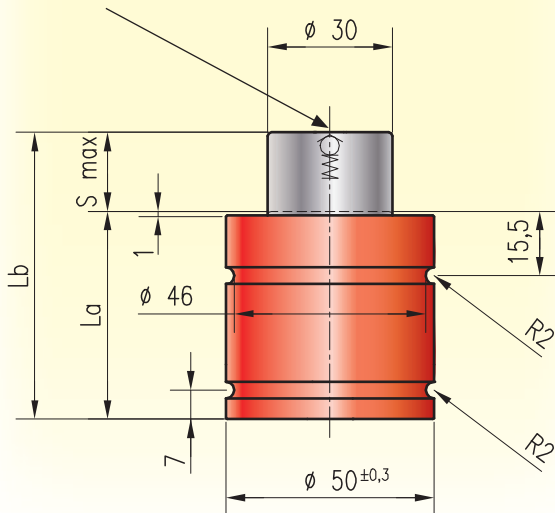

Force disponible lorsque la course de la tige varie.  
Pression de chargement: 15 MPa.  
Force available at different lengths of stroke.  
Charging pressure: 15 MPa.  
Bei Veränderung des Kolbenstangenhubs verfügbare Kraft.  
Ladedruck: 15 MPa.

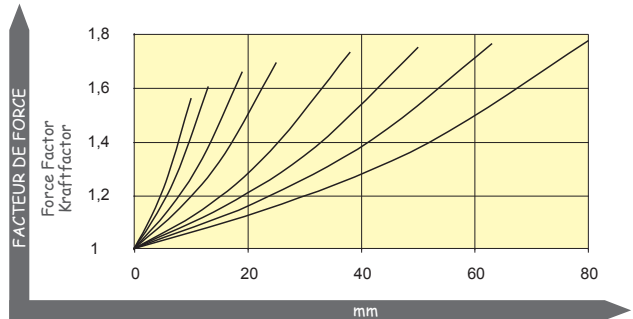

P max	P min	max	max	V max
15 Mpa	2 MPa	80 C°	0,0367/1°C	12 m/min

REF. 273 KCR=10 S=80

273-10-80

\* sur demande / on request / auf Anfrage

Code	La mm	Lb mm	Fo daN	F daN	P MPa	V l	A cm <sup>2</sup>	Poids Kg	KCR	S (max) mm	REF. 273
KCR 10-10	41	51	1000 (±5%)	1649	15	0,019	7,065	0,48	10	10	*
KCR 10-13	44	57		1696		0,024		0,51		13	*
KCR 10-19	50	69		1755		0,033		0,55		19	*
KCR 10-25	56	81		1789		0,043		0,6		25	*
KCR 10-38	69	107		1831		0,063		0,7		38	*
KCR 10-50	81	131		1852		0,082		0,8		50	*
KCR 10-63	94	157		1866		0,102		0,9		63	*
KCR 10-80	111	191		1878		0,129		0,95		80	*



# RESSORT A GAZ KCR 15

GAS SPRING KCR 15  
GASDRUCKFEDERN KCR 15



2 Taraudages M8 Prof. 6 mm  
2 Holes M8 by 6 mm deep  
2 Bohrungen M8 6 mm tief

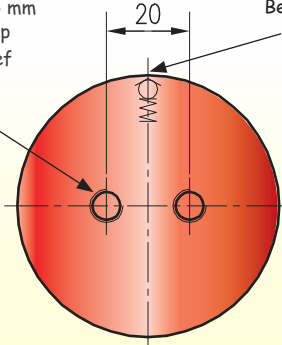

**1500 daN**  
**Ø 63**

Orifice de chargement/déchargement M6  
Charging hole M6  
Befüllungsbohrung M6

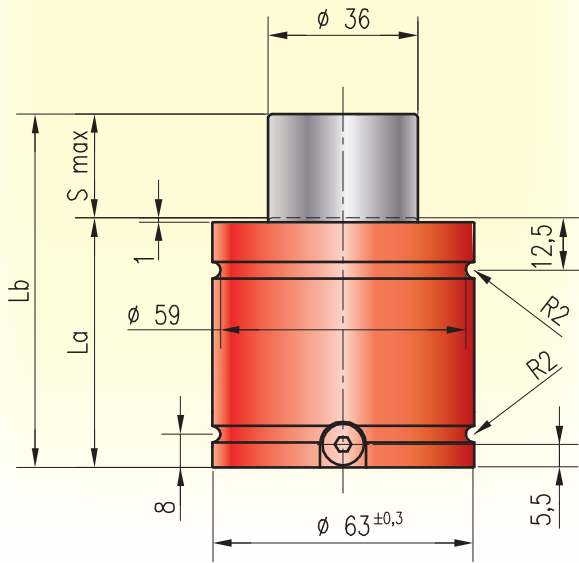
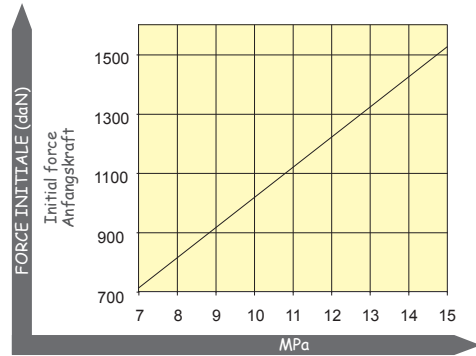

Force disponible lorsque la course de la tige varie.  
Pression de chargement: 15 MPa.  
Force available at different lengths of stroke.  
Charging pressure: 15 MPa.  
Bei Veränderung des Kolbenstangenhubs verfügbare Kraft.  
Ladedruck: 15 MPa.

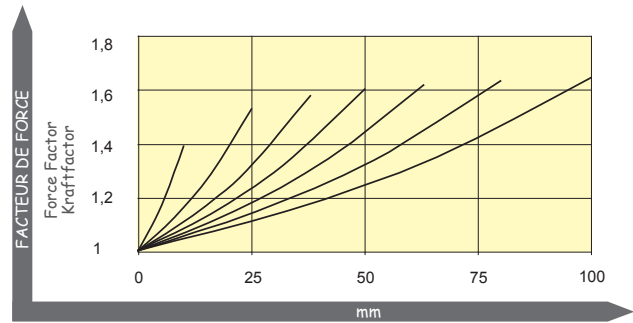

KCR 15

P max	P min	max	max	V max
15 Mpa	2 MPa	80 C°	0,0367/1°C	12 m/min

REF. 273 KCR=15 S=80

273-15-80

\* sur demande / on request / auf Anfrage

Code	La mm	Lb mm	Fo daN	F daN	P MPa	V l	A cm <sup>2</sup>	Poids Kg	KCR	S (max) mm	REF. 273
KCR 15-10	45	55	1500 (±5%)	2116	15	0,036	10,17	0,8	15	10	*
KCR 15-25	60	85		2327		0,073		1		25	*
KCR 15-38	73	111		2398		0,106		1,1		38	*
KCR 15-50	85	135		2436		0,136		1,2		50	*
KCR 15-63	98	161		2462		0,168		1,3		63	*
KCR 15-80	115	195		2484		0,21		1,3		80	*
KCR 15-100	135	235		2501		0,26		1,8		100	*

# RESSORT A GAZ KCR 24

GAS SPRING KCR 24  
GASDRUCKFEDERN KCR 24



Orifice de chargement/déchargement M6  
Charging hole M6  
Befüllungsbohrung M6

4 Taraudages M8 Prof. 6 mm  
4 Holes M8 by 6 mm deep  
4 Bohrungen M8 6 mm tief

**2400 daN**  
**Ø 75**

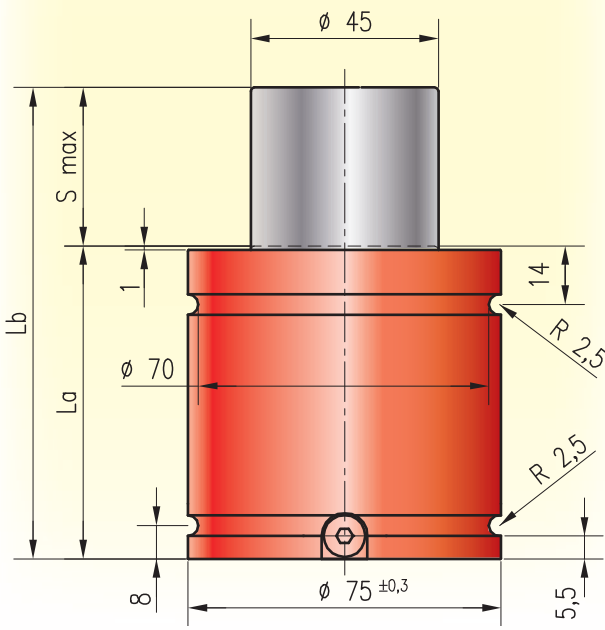
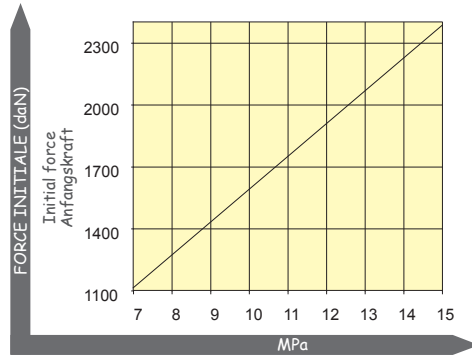
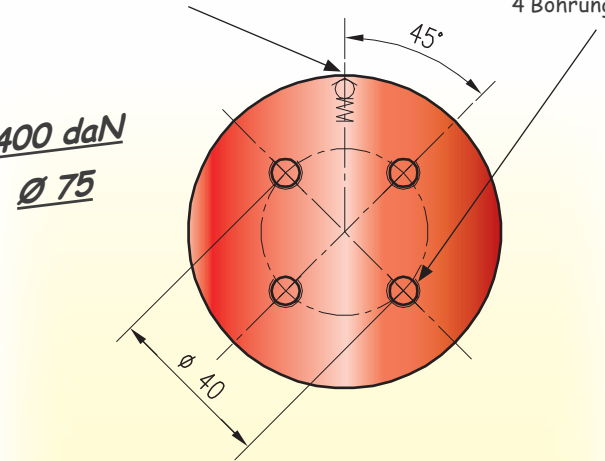

Force disponible lorsque la course de la tige varie.  
Pression de chargement: 15 MPa.  
Force available at different lengths of stroke.  
Charging pressure: 15 MPa.  
Bei Veränderung des Kolbenstangenhubs verfügbare Kraft.  
Ladedruck: 15 MPa.

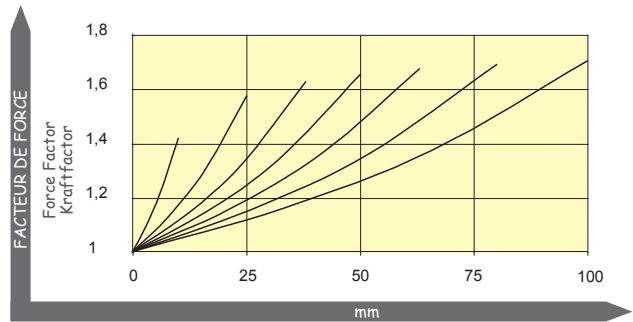

P max	P min	max	max	V max
15 Mpa	2 MPa	80 C°	0,0367/1°C	12 m/min

REF. 273 KCR=15 S=80

273-15-80

\* sur demande / on request / auf Anfrage

Code	La mm	Lb mm	Fo daN	F daN	P MPa	V l	A cm <sup>2</sup>	Poids Kg	KCR	S (max) mm	REF. 273
KCR 24-10	47	57	2400 (±5%)	3374	15	0,054	15,89	1	24	10	*
KCR 24-25	62	87		3745		0,109		1,4		25	*
KCR 24-38	75	113		3871		0,157		1,6		38	*
KCR 24-50	87	137		3938		0,201		1,7		50	*
KCR 24-63	100	163		3985		0,249		2		63	*
KCR 24-80	117	197		4026		0,311		2,2		80	*
KCR 24-100	137	237		4058		0,385		2,5		100	*

# RESSORT A GAZ AR 1,5

GAS SPRING AR 1,5  
GASDRUCKFEDERN AR 1,5



**150 daN**  
**Ø 32**

Taraudage M8 Profondeur 6 mm  
Hole M8 by 6 mm deep  
Bohrung M8 6 mm tief

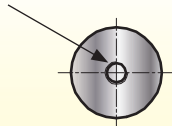

Orifice de chargement/déchargement M6  
Charging hole M6  
Befüllungsbohrung M6

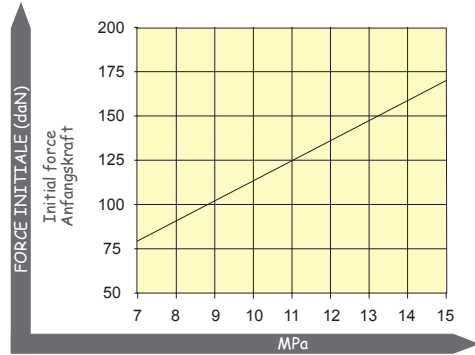
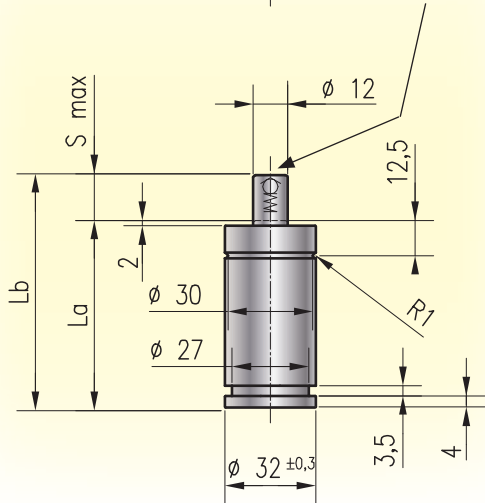

Force disponible lorsque la course de la tige varie.  
Pression de chargement: 15 MPa.  
Force available at different lengths of stroke.  
Charging pressure: 15 MPa.  
Bei Veränderung des Kolbenstangenhubs verfügbare Kraft.  
Ladedruck: 15 MPa.

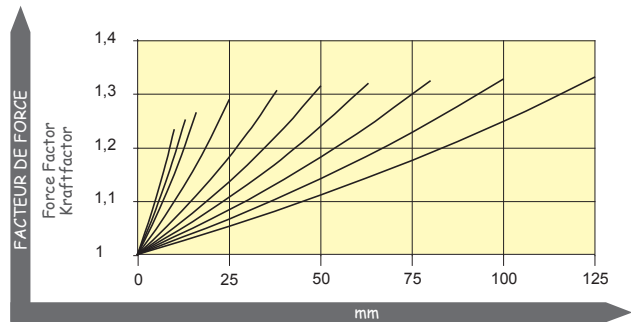

AR 1,5

P max	P min	max		V max
15 Mpa	2 MPa	80 C°	0,0367/1°C	12 m/min

REF. 274 AR=1,5 S=25 mm

274-1,5-25

\* sur demande / on request / auf Anfrage

Code	La mm	Lb mm	Fo daN	F daN	P MPa	V l	A cm <sup>2</sup>	Poids Kg	ISO	AR	S (max) mm	REF. 274
AR 1,5-10	60	70	150 (±5%)	208	15	0,006	1,13	0,3		1,5	10	*
AR 1,5-13	63	76		212		0,007		0,32	√		13	*
AR 1,5-16	66	82		214		0,008		0,33			16	*
AR 1,5-25	75	100		218		0,012		0,37	√		25	*
AR 1,5-38	88	126		221		0,018		0,42			38	*
AR 1,5-50	100	150		222		0,023		0,47	√		50	*
AR 1,5-63	113	176		223		0,029		0,52	√		63	*
AR 1,5-80	130	210		224		0,037		0,6	√		80	*
AR 1,5-63	150	250		225		0,045		0,75			100	*
AR 1,5-63	175	300		226		0,056		0,85			125	*

# RESSORT A GAZ AR 2,5

GAS SPRING AR 2,5  
GASDRUCKFEDERN AR 2,5



**250 daN**  
**Ø 38**

Taraudage M8 Profondeur 6 mm  
Hole M8 by 6 mm deep  
Bohrung M8 6 mm tief

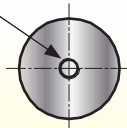

Orifice de chargement/déchargement M6  
Charging hole M6  
Befüllungsbohrung M6

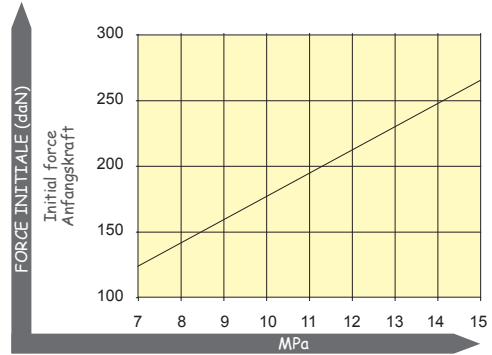
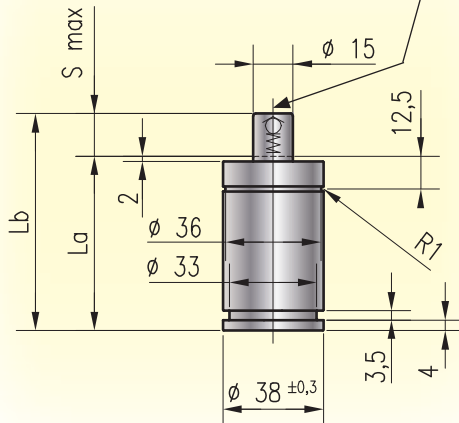

Force disponible lorsque la course de la tige varie.  
Pression de chargement: 15 MPa.  
Force available at different lengths of stroke.  
Charging pressure: 15 MPa.  
Bei Veränderung des Kolbenstangenhubs verfügbare Kraft.  
Ladedruck: 15 MPa.

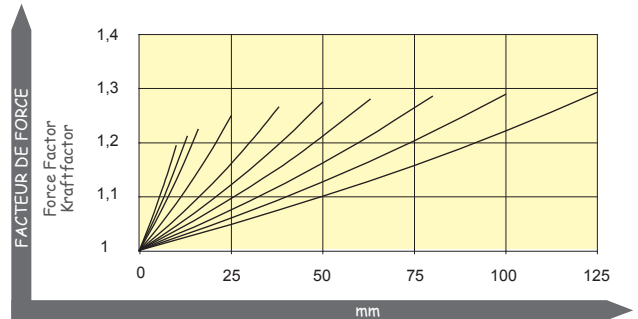

P max	P min	max	max	V max
15 Mpa	2 MPa	80 C°	0,0367/1°C	12 m/min

REF. 274 AR=2,5 S=25 mm

274-2,5-25

\* sur demande / on request / auf Anfrage

Code	La mm	Lb mm	Fo daN	F daN	P MPa	V l	A cm <sup>2</sup>	Poids Kg	ISO	AR	S (max) mm	REF. 274
AR 2,5-10	60	70	250 (±5%)	316	15	0,01	1,767	0,43	✓	2,5	10	*
AR 2,5-13	63	76		320		0,013		0,44			13	*
AR 2,5-16	66	82		324		0,015		0,46			16	*
AR 2,5-25	75	100		330		0,022		0,51			25	*
AR 2,5-38	88	126		335		0,032		0,59			38	*
AR 2,5-50	100	150		337		0,041		0,66			50	*
AR 2,5-63	113	176		339		0,051		0,73			63	*
AR 2,5-80	130	210		340		0,063		0,83			80	*
AR 2,5-100	150	250		342		0,079		0,96			100	*
AR 2,5-125	175	300		343		0,097		1,05			125	*



RESSORT A GAZ AR 5

GAS SPRING AR 5  
GASDRUCKFEDERN AR 5



Orifice de chargement/déchargement 1/8" Gaz  
Charging hole 1/8" Gas  
Befüllungsbohrung 1/8" Gas

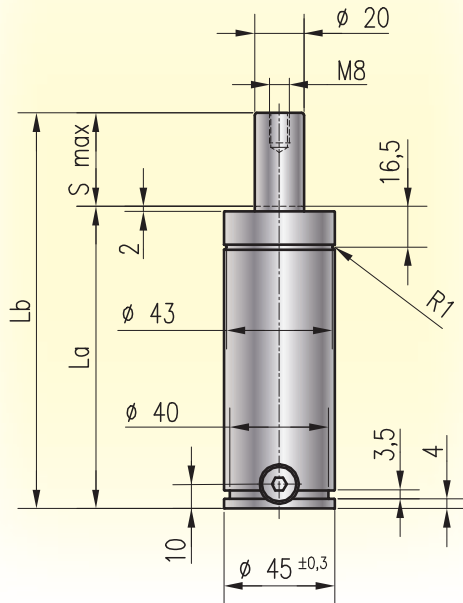
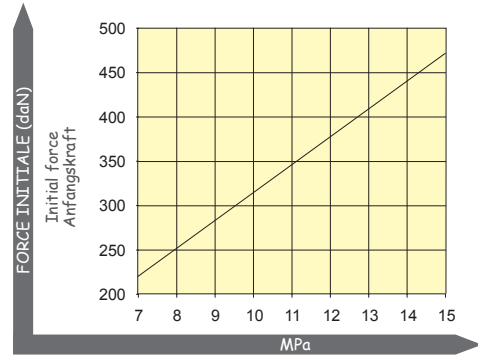
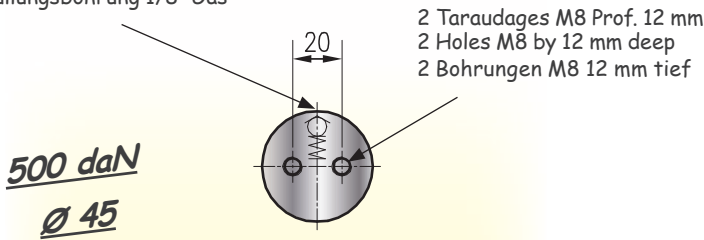

Force disponible lorsque la course de la tige varie.  
Pression de chargement: 15 MPa.  
Force available at different lengths of stroke.  
Charging pressure: 15 MPa.  
Bei Veränderung des Kolbenstangenhubs verfügbare Kraft.  
Ladedruck: 15 MPa.

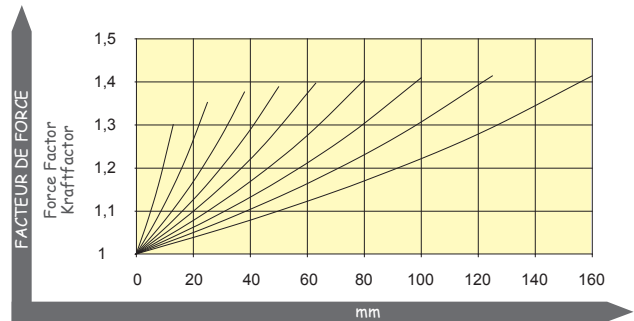

AR 5

P max	P min	max	max	V max
15 Mpa	2 MPa	80 C°	0,0367/1°C	12 m/min

REF. 274 AR=5 S=25

274-5-25

\* sur demande / on request / auf Anfrage

Code	La mm	Lb mm	Fo daN	F daN	P MPa	V l	A cm <sup>2</sup>	Poids Kg	ISO	AR	S (max) mm	REF. 274
AR 5-13	98	111	500 (±5%)	611	15	0,017	3,14	0,9		5	13	*
AR 5-25	110	135		637		0,03		0,99	✓		25	*
AR 5-38	123	161		648		0,043		1,12			38	*
AR 5-50	135	185		653		0,056		1,21	✓		50	*
AR 5-63	148	211		658		0,069		1,34			63	*
AR 5-80	165	245		661		0,087		1,5	✓		80	*
AR 5-100	185	285		665		0,108		1,68	✓		100	*
AR 5-125	210	335		666		0,134		1,8	✓		125	*
AR 5-160	245	405		668		0,17		2			160	*

# RESSORT A GAZ AR 7,5

GAS SPRING AR 7,5  
GASDRUCKFEDERN AR 7,5



Orifice de chargement/déchargement 1/8" Gaz  
Charging hole 1/8" Gas  
Befüllungsbohrung 1/8" Gas

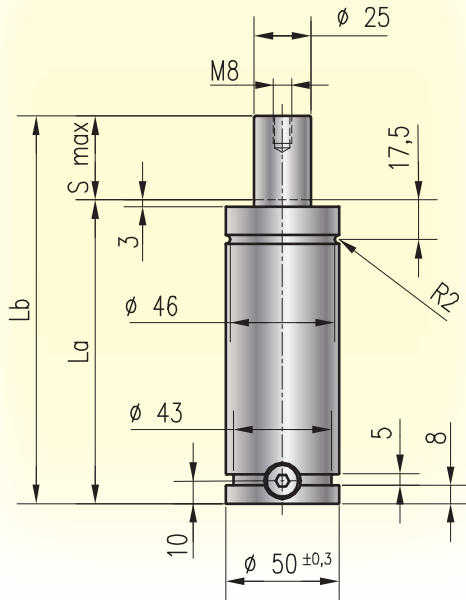
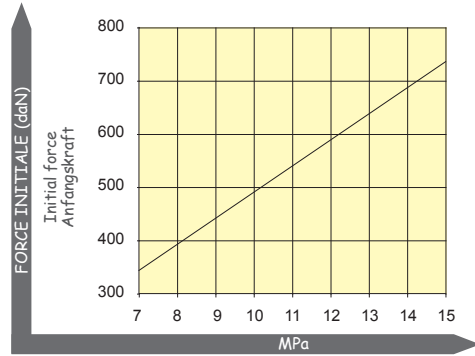
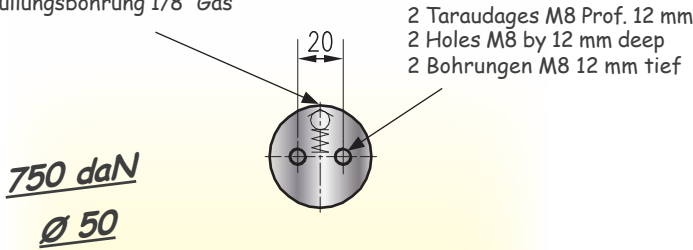

Force disponible lorsque la course de la tige varie.  
Pression de chargement: 15 MPa.  
Force available at different lengths of stroke.  
Charging pressure: 15 MPa.  
Bei Veränderung des Kolbenstangenhubs verfügbare Kraft.  
Ladedruck: 15 MPa.

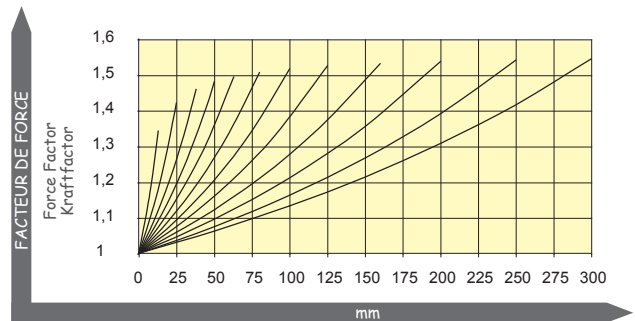

P max	P min	max		V max
15 Mpa	2 MPa	80 C°	0,0367/1°C	12 m/min

REF. 274 AR=7,5 S=50

274-7,5-50

\* sur demande / on request / auf Anfrage

Code	La mm	Lb mm	Fo daN	F daN	P MPa	V l	A cm <sup>2</sup>	Poids Kg	ISO	AR	S (max) mm	REF. 274
AR 7,5-13	108	121	750 (±5%)	987	15	0,025	4,906	1,2	✓	7,5	13	*
AR 7,5-25	120	145		1044		0,042		1,35			25	*
AR 7,5-38	133	171		1073		0,06		1,4			38	*
AR 7,5-50	145	195		1089		0,076		1,52			50	*
AR 7,5-63	158	221		1099		0,094		1,7			63	*
AR 7,5-80	175	255		1108		0,117		1,82			80	*
AR 7,5-100	195	295		1115		0,145		1,85			100	*
AR 7,5-125	220	345		1121		0,179		2,2			125	*
AR 7,5-160	255	415		1126		0,227		2,3			160	*
AR 7,5-200	295	495		1130		0,281		3,1			200	*
AR 7,5-250	345	595		1135		0,35		3,6			250	*
AR 7,5-300	395	695		1137		0,418		4,15			300	*



# RESSORT A GAZ AR 15

GAS SPRING AR 15  
GASDRUCKFEDERN AR 15



Orifice de chargement/déchargement 1/8" Gaz  
Charging hole 1/8" Gas  
Befüllungsbohrung 1/8" Gas

4 Taraudages M8 Prof. 12 mm  
4 Holes M8 by 12 mm deep  
4 Bohrungen M8 12 mm tief

**1500 daN**  
**Ø 75**

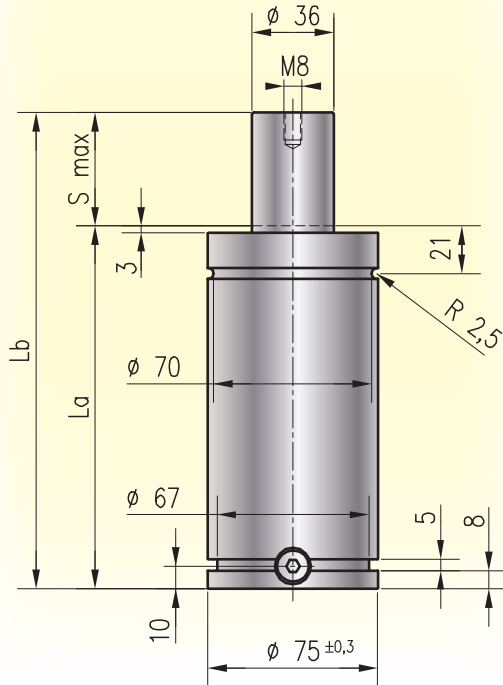
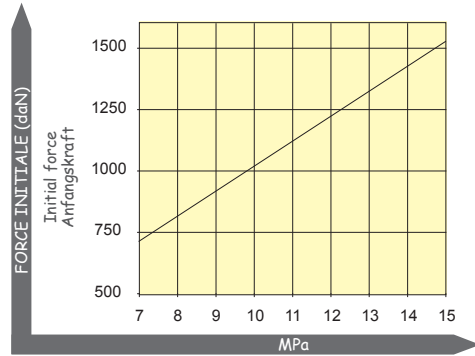
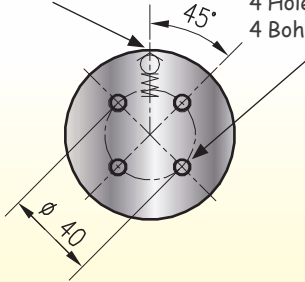

Force disponible lorsque la course de la tige varie.  
Pression de chargement: 15 MPa.  
Force available at different lengths of stroke.  
Charging pressure: 15 MPa.  
Bei Veränderung des Kolbenstangenhubs verfügbare Kraft.  
Ladedruck: 15 MPa.

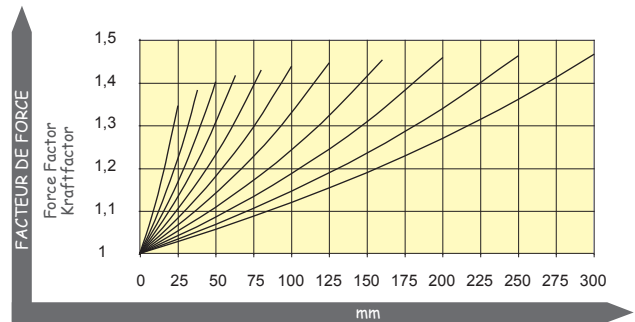

P max	P min	max		V max
15 Mpa	2 MPa	80 C°	0,0367/1°C	12 m/min

AR 15

REF. 274 AR=15 S=50

274-15-50

\* sur demande / on request / auf Anfrage

Code	La mm	Lb mm	Fo daN	F daN	P MPa	V l	A cm <sup>2</sup>	Poids Kg	ISO	AR	S (max) mm	REF. 274
AR 15-25	135	160	1500 (±5%)	2050	15	0,1	10,17	3,3	✓	15	25	*
AR 15-38	148	186		2106		0,14		3,5	*			
AR 15-50	160	210		2136		0,18		3,65	✓		50	*
AR 15-63	173	236		2158		0,22		3,9	*		63	*
AR 15-80	190	270		2176		0,27		4,45	✓		80	*
AR 15-100	210	310		2191		0,34		4,8	✓		100	*
AR 15-125	235	360		2203		0,41		5,36	✓		125	*
AR 15-160	270	430		2215		0,52		6,1	✓		160	*
AR 15-200	310	510		2222		0,65		7,15	✓		200	*
AR 15-250	360	610		2250		0,81		7,86	*		250	*
AR 15-300	410	710		2300		0,96		8,86	*		300	*

# RESSORT A GAZ AR 30

GAS SPRING AR 30  
GASDRUCKFEDERN AR 30



Orifice de chargement/déchargement 1/8" Gaz  
Charging hole 1/8" Gas  
Befüllungsbohrung 1/8" Gas

4 Taraudages M8 Prof. 12 mm  
4 Holes M8 by 12 mm deep  
4 Bohrungen M8 12 mm tief

**3000 daN**  
**Ø 95**

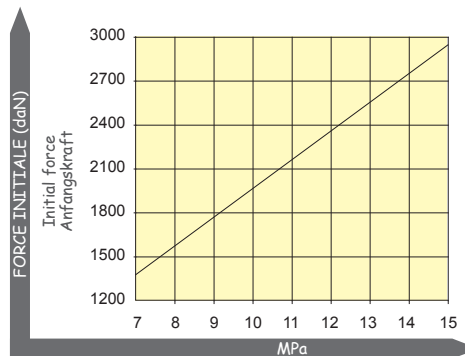
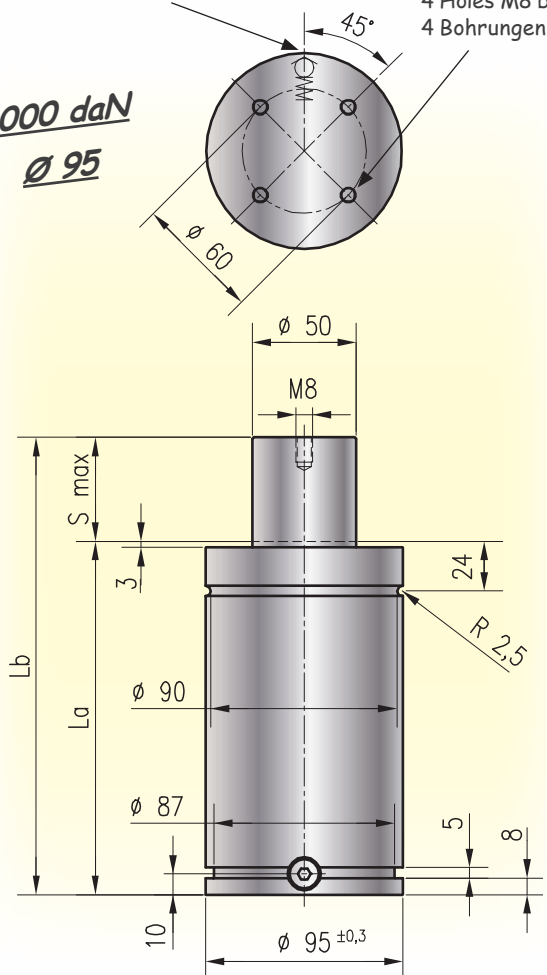

Force disponible lorsque la course de la tige varie.  
Pression de chargement: 15 MPa.  
Force available at different lengths of stroke.  
Charging pressure: 15 MPa.  
Bei Veränderung des Kolbenstangenhubes verfügbare Kraft.  
Ladedruck: 15 MPa.

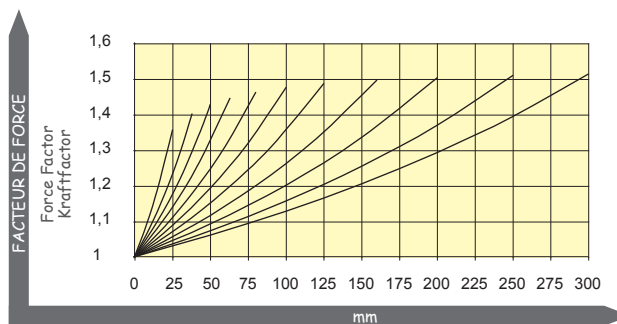

P max	P min	max		V max
15 Mpa	2 MPa	80 C°	0,0367/1°C	12 m/min

REF. 274 AR=30 S=80

274-30-80

\* sur demande / on request / auf Anfrage

Code	La mm	Lb mm	Fo daN	F daN	P MPa	V l	A cm <sup>2</sup>	Poids Kg	ISO	AR	S (max) mm	REF. 274
AR 30-25	145	170	3000 (±5%)	3986	15	0,187	19,62	5,75	✓	30	25	*
AR 30-38	158	196		4121		0,26		6,15	*			
AR 30-50	170	220		4195		0,328		6,53	✓		50	*
AR 30-63	183	246		4251		0,401		6,91	*		63	*
AR 30-80	200	280		4300		0,497		7,25	✓		80	*
AR 30-100	220	320		4337		0,61		8	✓		100	*
AR 30-125	245	370		4357		0,751		8,15	✓		125	*
AR 30-160	280	440		4398		0,948		9,24	✓		160	*
AR 30-200	320	520		4419		1,174		10,31	✓		200	*
AR 30-250	370	620		4442		1,456		11,9	*		250	*
AR 30-300	420	720		4455		1,738		14,87	*		300	*

# RESSORT A GAZ AR 50

GAS SPRING AR 50  
GASDRUCKFEDERN AR 50



Orifice de chargement/déchargement 1/8" Gaz  
Charging hole 1/8" Gas  
Befüllungsbohrung 1/8" Gas

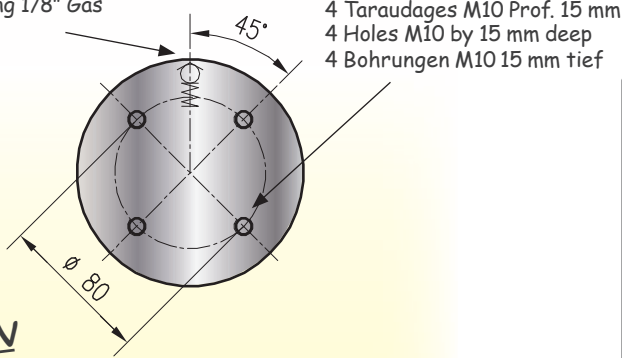

**5000 daN**  
**Ø 120**

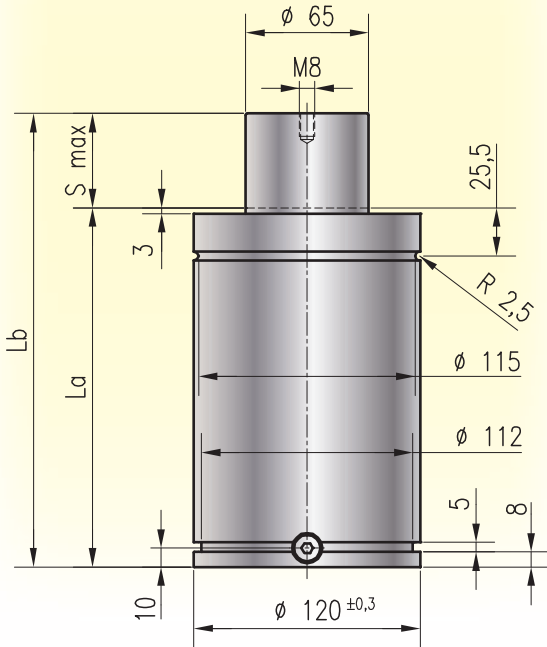
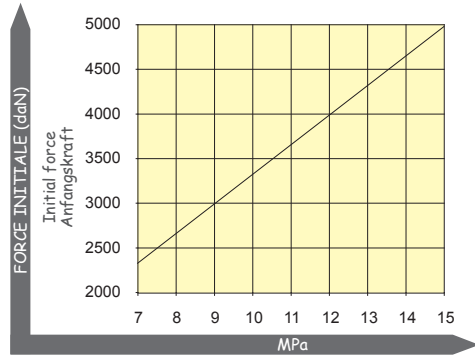

Force disponible lorsque la course de la tige varie.  
Pression de chargement: 15 MPa.  
Force available at different lengths of stroke.  
Charging pressure: 15 MPa.  
Bei Veränderung des Kolbenstangenhubs verfügbare Kraft.  
Ladedruck: 15 MPa.

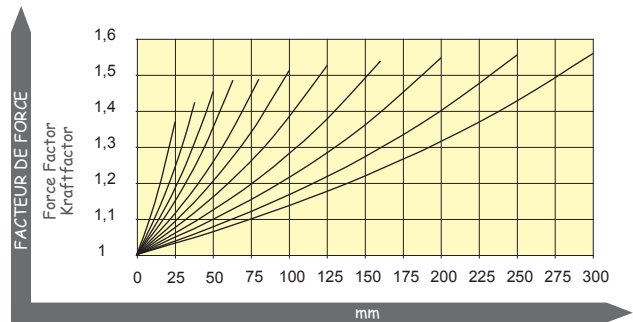

AR 50

P max	P min	max		V max
15 Mpa	2 MPa	80 C°	0,0367/1°C	12 m/min

REF. 274 AR=50 S=80

274-50-80

\* sur demande / on request / auf Anfrage

Code	La mm	Lb mm	Fo daN	F daN	P MPa	V l	A cm <sup>2</sup>	Poids Kg	ISO	AR	S (max) mm	REF. 274
AR 50-25	165	190	5000 (±5%)	6796	15	0,309	33,16	12,01	✓	50	25	*
AR 50-38	178	216		7064		0,425		12,85	*			
AR 50-50	190	240		7216		0,533		13,6	✓		50	*
AR 50-63	203	266		7369		0,642		14,5	*			
AR 50-80	220	300		7383		0,813		15,39	✓		80	*
AR 50-100	240	340		7509		0,982		16,48	✓		100	*
AR 50-125	265	390		7575		1,207		18,05	✓		125	*
AR 50-160	300	460		7638		1,521		19,83	✓		160	*
AR 50-200	340	540		7681		1,881		21,7	✓		200	*
AR 50-250	390	640		7729		2,33		23,85	*		250	*
AR 50-300	440	740		7755		2,779		25,6	*		300	*

# RESSORT A GAZ AR 75

GAS SPRING AR 75  
GASDRUCKFEDERN AR 75



Orifice de chargement/déchargement 1/8" Gaz  
Charging hole 1/8" Gas  
Befüllungsbohrung 1/8" Gas

4 Taraudages M10 Prof. 15 mm  
4 Holes M10 by 15 mm deep  
4 Bohrungen M10 15 mm tief

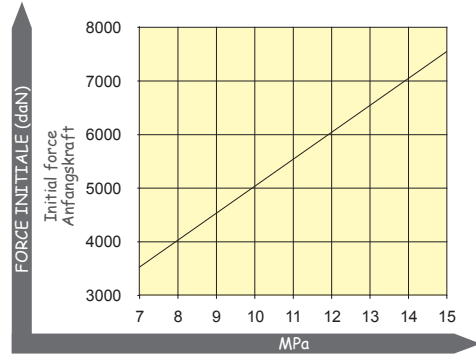
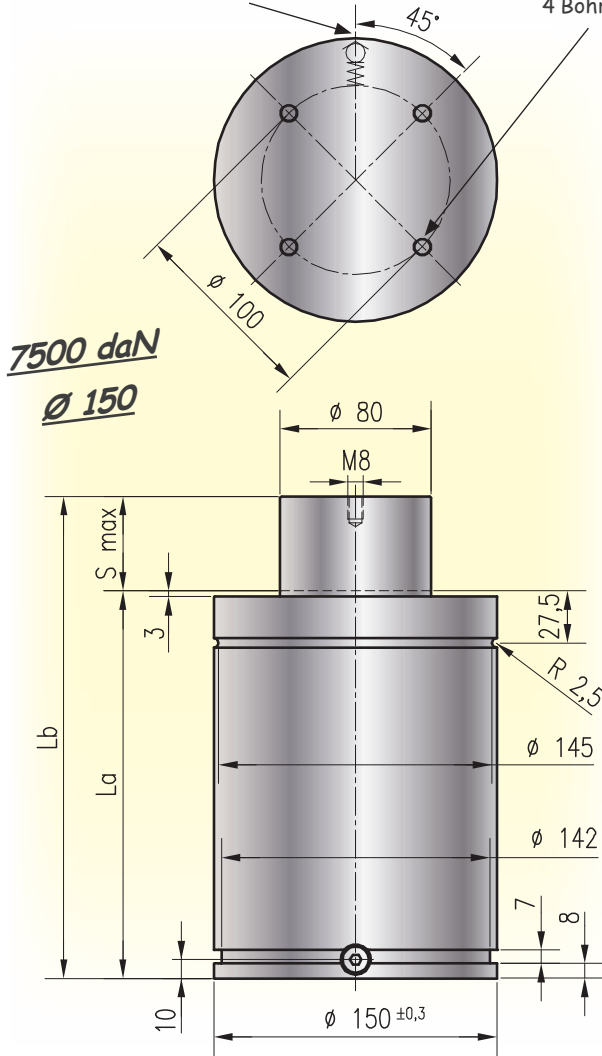

Force disponible lorsque la course de la tige varie.  
Pression de chargement: 15 MPa.  
Force available at different lengths of stroke.  
Charging pressure: 15 MPa.  
Bei Veränderung des Kolbenstangenhubs verfügbare Kraft.  
Ladedruck: 15 MPa.

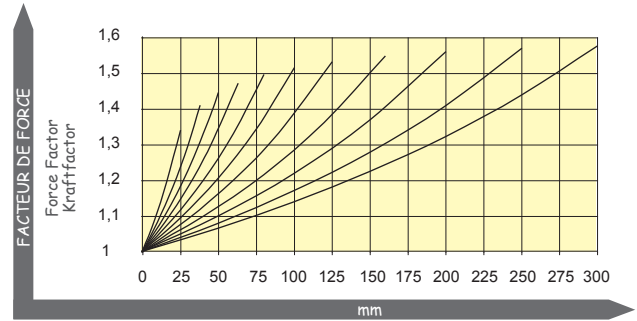

P max	P min	max		V max
15 Mpa	2 MPa	80 C°	0,0367/1°C	12 m/min

REF. 274 AR=75 S=100

274-75-100

\* sur demande / on request / auf Anfrage

Code	La mm	Lb mm	Fo daN	F daN	P MPa	V l	A cm <sup>2</sup>	Poids Kg	ISO	AR	S (max) mm	REF. 274
AR 75-25	180	205	7500 (±5%)	10078	15	0,498	50,24	19,5	√	75	25	*
AR 75-38	193	231		10600		0,66		20,6	*			
AR 75-50	205	255		10867		0,82		21,5	√		50	*
AR 75-63	218	281		11068		0,992		22,3	*		63	*
AR 75-80	235	315		11249		1,218		23,7	√		80	*
AR 75-100	255	355		11394		1,483		25,4	√		100	*
AR 75-125	280	405		11525		1,815		27	√		125	*
AR 75-160	315	475		11641		2,278		30,6	√		160	*
AR 75-200	355	555		11731		2,81		33,8	√		200	*
AR 75-250	405	655		11815		3,473		37,4	*		250	*
AR 75-300	455	755		11866		4,136		40,1	*		300	*

# RESSORT A GAZ AR 100

GAS SPRING AR 100  
GASDRUCKFEDERN AR 100



Orifice de chargement/déchargement 1/8" Gaz  
Charging hole 1/8" Gas  
Befüllungsbohrung 1/8" Gas

4 Taraudages M12 Prof. 16 mm  
4 Holes M12 by 16 mm deep  
4 Bohrungen M12 16 mm tief

**10000 daN**  
**Ø 195**

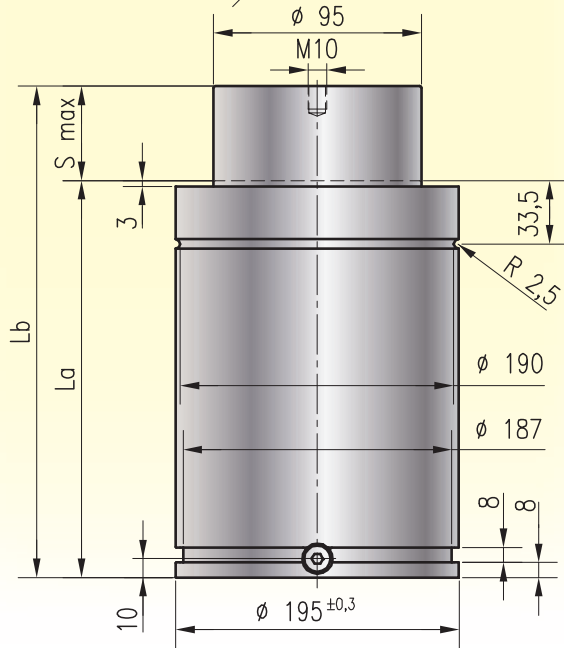
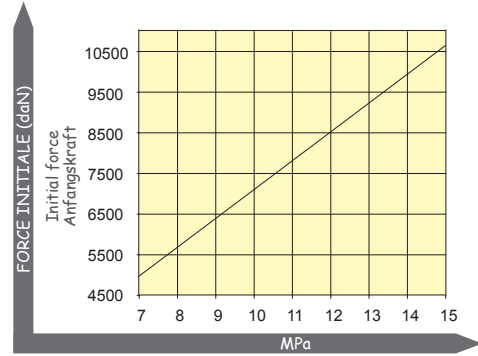
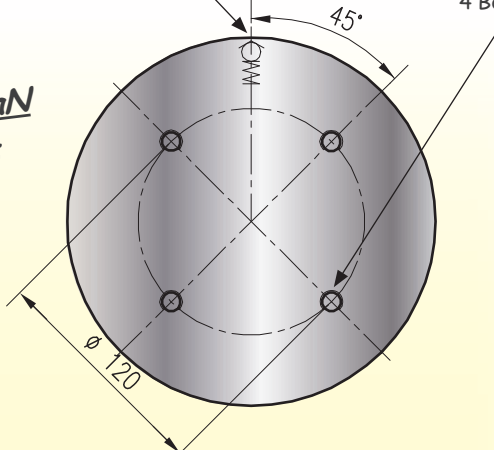

Force disponible lorsque la course de la tige varie.  
Pression de chargement: 15 MPa.  
Force available at different lengths of stroke.  
Charging pressure: 15 MPa.  
Bei Veränderung des Kolbenstangenhubs verfügbare Kraft.  
Ladedruck: 15 MPa.

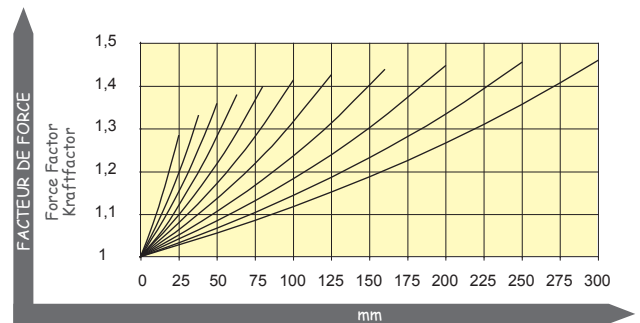

P max	P min	max		V max
15 Mpa	2 MPa	80 C°	0,0367/1°C	12 m/min

AR 100

REF. 274 AR=100 S=160

274-100-160

\* sur demande / on request / auf Anfrage

Code	La mm	Lb mm	Fo daN	F daN	P MPa	V l	A cm <sup>2</sup>	Poids Kg	ISO	AR	S (max) mm	REF. 274
AR 100-25	185	210	10000 (±5%)	13615	15	0,805	70,84	35,6	✓	100	25	*
AR 100-38	198	236		14118		1,087		37,3	*			
AR 100-50	210	260		14409		1,348		39,1	✓		50	*
AR 100-63	223	286		14628		1,626		41,2			63	*
AR 100-80	240	320		14827		1,998		43,5	✓		80	*
AR 100-100	260	360		14990		2,432		46,1	✓		100	*
AR 100-125	285	410		15124		2,974		50,5	✓		125	*
AR 100-160	320	480		15252		3,733		55,9	✓		160	*
AR 100-200	360	560		15351		4,6		62	✓		200	*
AR 100-250	410	660		15447		5,685		67,3			250	*
AR 100-300	460	760		14403		6,769		74,8			300	*

# RESSORT A GAZ AR/P 5

GAS SPRING AR/P 5  
GASDRUCKFEDERN AR/P 5



**500 daN**  
**Ø 38**

Taroudage M8 Profondeur 6 mm  
Hole M8 by 6 mm deep  
Bohrung M8 6 mm tief

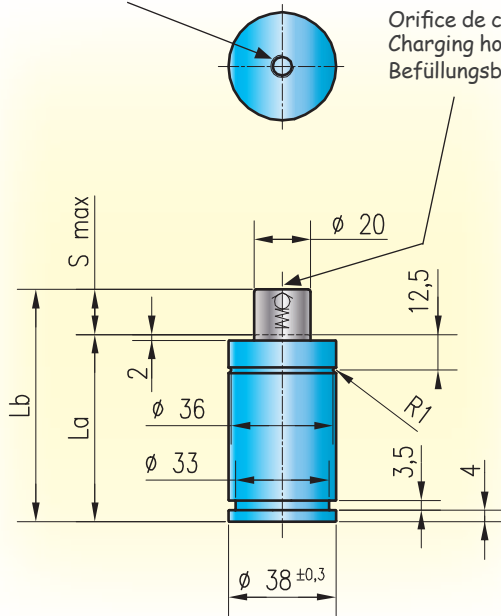

Orifice de chargement/déchargement M6  
Charging hole M6  
Befüllungsbohrung M6

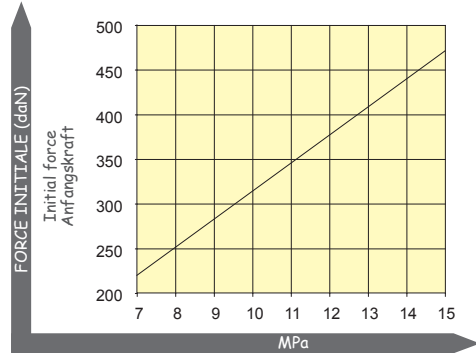

Force disponible lorsque la course de la tige varie.  
Pression de chargement: 15 MPa.  
Force available at different lengths of stroke.  
Charging pressure: 15 MPa.  
Bei Veränderung des Kolbenstangenhubs verfügbare Kraft.  
Ladedruck: 15 MPa.

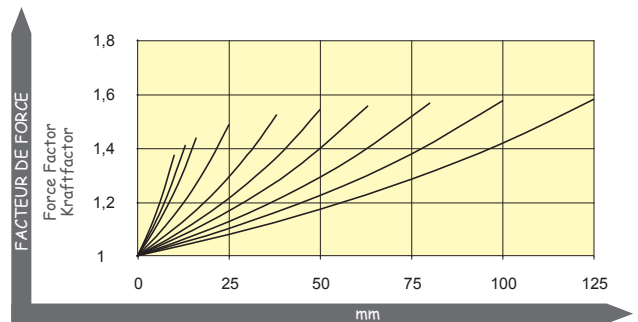

P max	P min	max	max	V max
15 Mpa	2 MPa	80 C°	0,0367/1°C	12 m/min

REF. 275 AR/P=5 S=80

275-5-80

\* sur demande / on request / auf Anfrage

Code	La mm	Lb mm	Fo daN	F daN	P MPa	V l	A cm <sup>2</sup>	Poids Kg	AR/P	S (max) mm	REF. 275
AR/P 5-10	60	70	500 (±5%)	633	15	0,012	3,14	0,43	5	10	*
AR/P 5-13	63	76		652		0,014		0,44		13	*
AR/P 5-16	66	82		665		0,017		0,46		16	*
AR/P 5-25	75	100		632		0,024		0,51		25	*
AR/P 5-38	88	126		710		0,035		0,59		38	*
AR/P 5-50	100	150		720		0,045		0,66		50	*
AR/P 5-63	113	176		727		0,056		0,73		63	*
AR/P 5-80	130	210		734		0,07		0,83		80	*
AR/P 5-100	150	250		744		0,092		0,96		100	*
AR/P 5-125	175	300		753		0,107		1,05		125	*



# RESSORT A GAZ AR/P 7,5

GAS SPRING AR/P 7,5  
GASDRUCKFEDERN AR/P 7,5



Orifice de chargement/déchargement 1/8" Gaz  
Charging hole 1/8" Gas  
Befüllungsbohrung 1/8" Gas

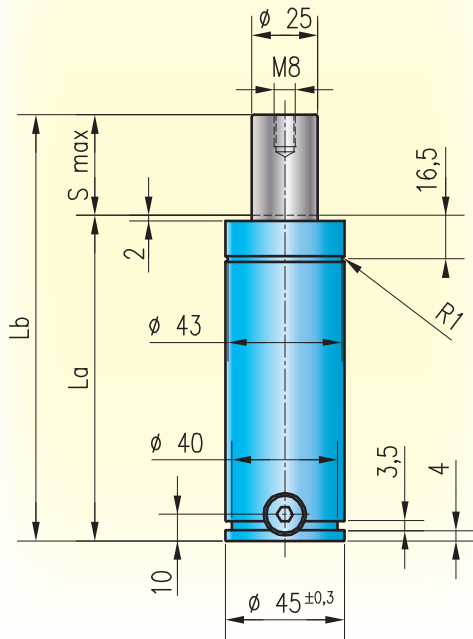
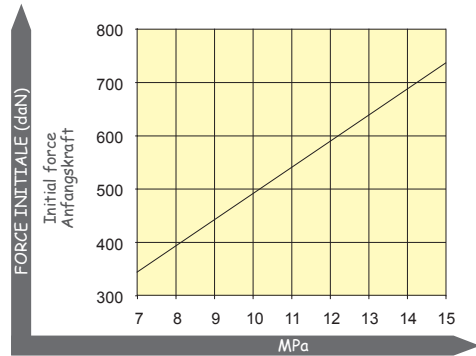
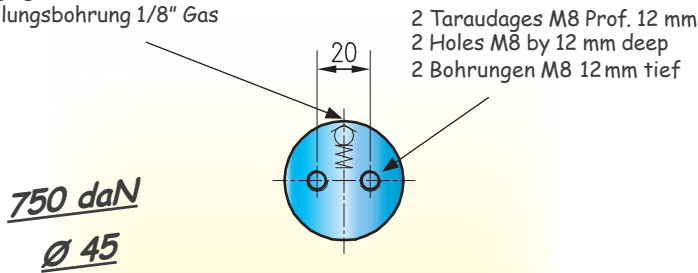

Force disponible lorsque la course de la tige varie.  
Pression de chargement: 15 MPa.  
Force available at different lengths of stroke.  
Charging pressure: 15 MPa.  
Bei Veränderung des Kolbenstangenhubs verfügbare Kraft.  
Ladedruck: 15 MPa.

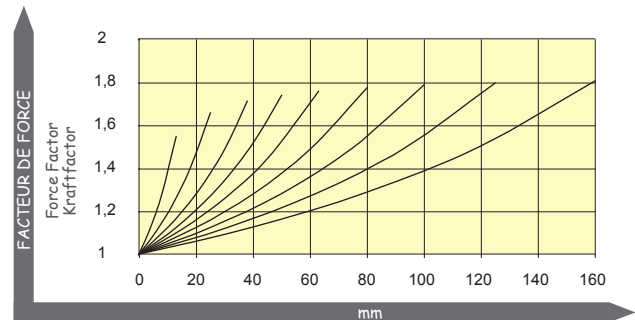

P max	P min	max	max	V max
15 Mpa	2 MPa	80 C°	0,0367/1°C	12 m/min

REF. 275 AR/P=7,5 S=80

275-7,5-80

\* sur demande / on request / auf Anfrage

Code	La mm	Lb mm	Fo daN	F daN	P MPa	V l	A cm <sup>2</sup>	Poids Kg	AR/P	S (max) mm	REF. 275
AR/P 7,5-13	98	111	750 (±5%)	1137	15	0,018	4,906	0,9	7,5	13	*
AR/P 7,5-25	110	135		1218		0,03		0,99		25	*
AR/P 7,5-38	123	161		1257		0,044		1,12		38	*
AR/P 7,5-50	135	185		1278		0,057		1,21		50	*
AR/P 7,5-63	148	211		1292		0,071		1,34		63	*
AR/P 7,5-80	165	245		1304		0,09		1,5		80	*
AR/P 7,5-100	185	285		1313		0,111		1,68		100	*
AR/P 7,5-125	210	335		1321		0,138		1,8		125	*
AR/P 7,5-160	245	405		1328		0,176		2		160	*

# RESSORT A GAZ AR/P 10

GAS SPRING AR/P 10  
GASDRUCKFEDERN AR/P 10



Orifice de chargement/déchargement 1/8" Gaz  
Charging hole 1/8" Gas  
Befüllungsbohrung 1/8" Gas

2 Taraudages M8 Prof. 12 mm  
2 Holes M8 by 12 mm deep  
2 Bohrungen M8 12mm tief

**1000 daN**  
**Ø 50**

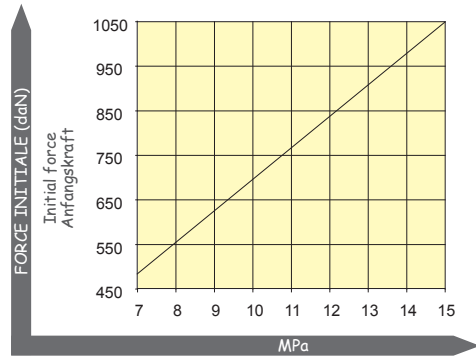
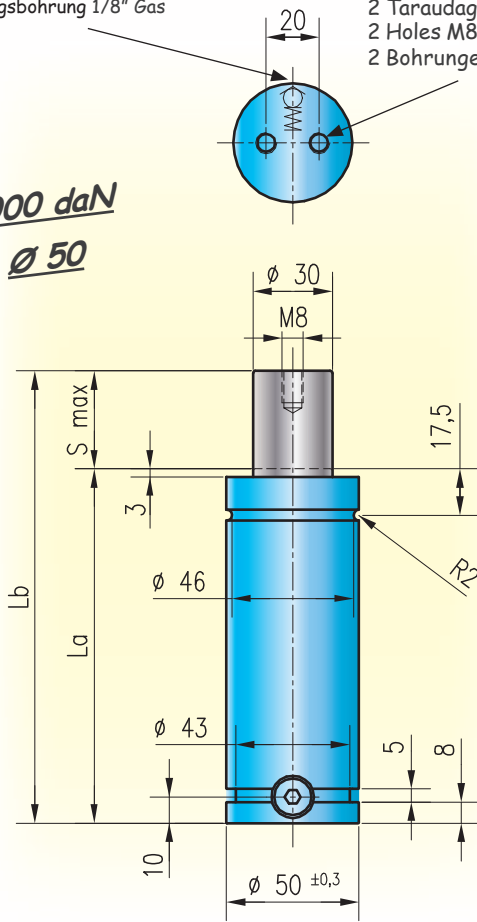

Force disponible lorsque la course de la tige varie.  
Pression de chargement: 15 MPa.  
Force available at different lengths of stroke.  
Charging pressure: 15 MPa.  
Bei Veränderung des Kolbenstangenhubs verfügbare Kraft.  
Ladedruck: 15 MPa.

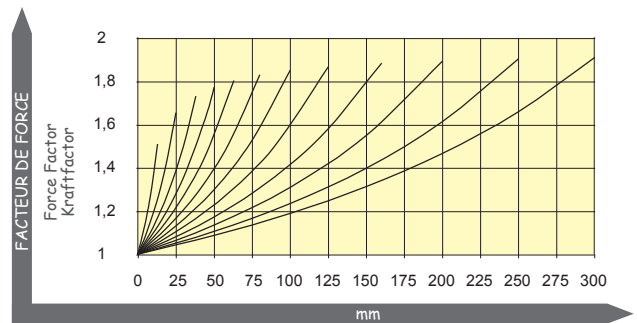

P max	P min	max		V max
15 Mpa	2 MPa	80 C°	0,0367/1°C	12 m/min

REF. 275 AR/P=10 S=200

275-10-200

\* sur demande / on request / auf Anfrage

Code	La mm	Lb mm	Fo daN	F daN	P MPa	V l	A cm <sup>2</sup>	Poids Kg	AR/P	S (max) mm	REF. 275
AR/P 10-13	108	121	1000 (±5%)	1595	15	0,027	7,065	1,2	10	13	*
AR/P 10-25	120	154		1748		0,044		1,35		*	
AR/P 10-38	133	171		1830		0,063		1,4		*	
AR/P 10-50	145	195		1874		0,081		1,52		*	
AR/P 10-63	158	221		1906		0,1		1,7		*	
AR/P 10-80	175	255		1934		0,12		1,82		*	
AR/P 10-100	195	295		1956		0,15		1,85		*	
AR/P 10-125	220	345		1975		0,19		2,2		*	
AR/P 10-160	255	415		1992		0,24		2,3		*	
AR/P 10-200	295	495		2004		0,3		3,1		*	
AR/P 10-250	345	595		2014		0,37		3,6		*	
AR/P 10-300	395	695		2021		0,44		4,15		*	



RESSORT A GAZ AR/P 24

GAS SPRING AR/P 24  
GASDRUCKFEDERN AR/P 24



Orifice de chargement/déchargement 1/8" Gaz  
Charging hole 1/8" Gas  
Befüllungsbohrung 1/8" Gas

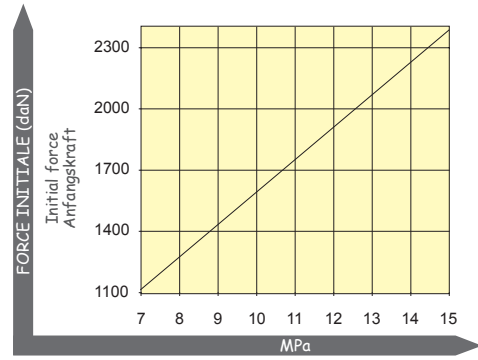
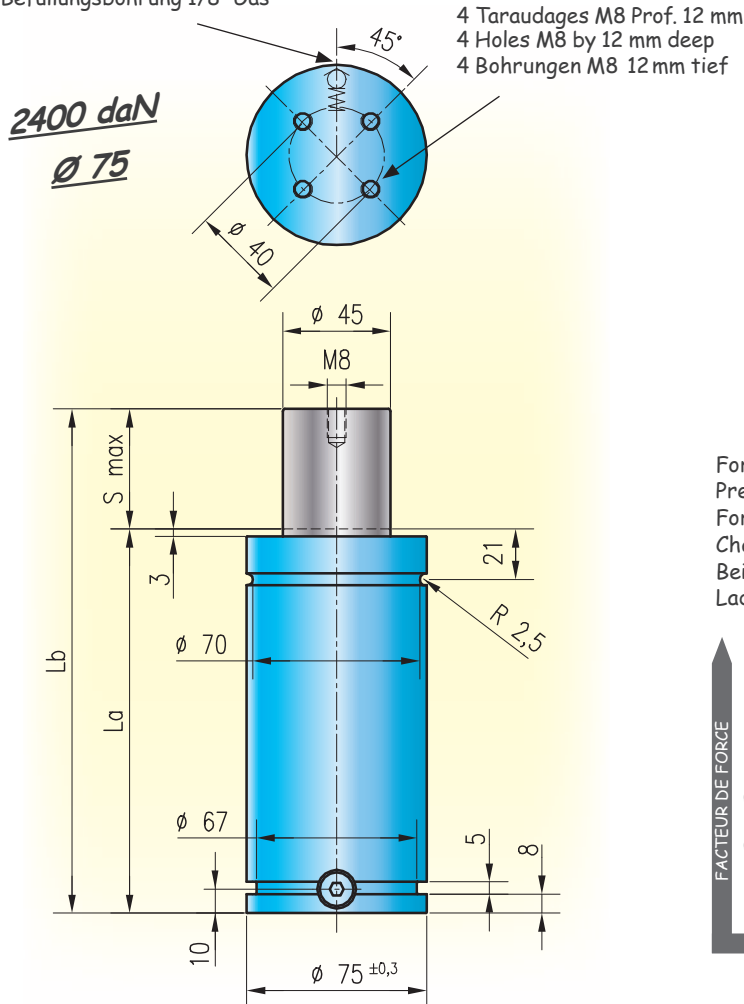

Force disponible lorsque la course de la tige varie.  
Pression de chargement: 15 MPa.  
Force available at different lengths of stroke.  
Charging pressure: 15 MPa.  
Bei Veränderung des Kolbenstangenhubs verfügbare Kraft.  
Ladedruck: 15 MPa.

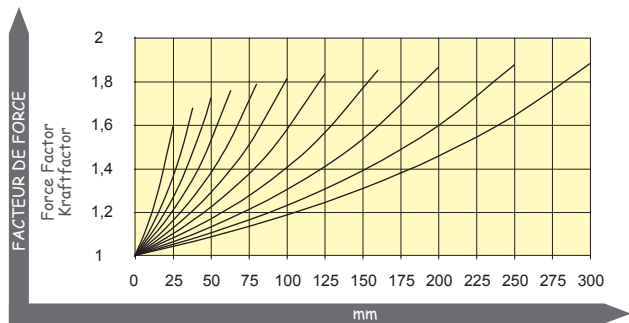

P max	P min	🌡️ max	🕒	V max
15 Mpa	2 MPa	80 C°	0,0367/1°C	12 m/min

REF. 275 AR/P=24 S=160

275-24-160

\* sur demande / on request / auf Anfrage

Code	La mm	Lb mm	Fo daN	F daN	P MPa	V l	A cm²	Poids Kg	AR/P	S (max) mm	REF. 275
AR/P 24-25	135	160	2400 (±5%)	3792	15	0,1	15,89	3,3	24	25	*
AR/P 24-38	148	186		3989		0,15		3,5		*	
AR/P 24-50	160	210		4100		0,18		3,65		*	
AR/P 24-63	173	236		4180		0,23		3,9		*	
AR/P 24-80	190	270		4253		0,28		4,45		*	
AR/P 24-100	210	310		4310		0,35		4,8		*	
AR/P 24-125	235	360		4358		0,43		5,36		*	
AR/P 24-160	270	430		4403		0,55		6,1		*	
AR/P 24-200	310	510		4435		0,68		7,15		*	
AR/P 24-250	360	610		4463		0,85		7,86		*	
AR/P 24-300	410	710		4481		1,019		8,86		*	

# RESSORT A GAZ AR/P 42

GAS SPRING AR/P 42  
GASDRUCKFEDERN AR/P 42



Orifice de chargement/déchargement 1/8" Gaz  
Charging hole 1/8" Gas  
Befüllungsbohrung 1/8" Gas

4 Taraudages M8 Prof. 12 mm  
4 Holes M8 by 12 mm deep  
4 Bohrungen M8 12 mm tief

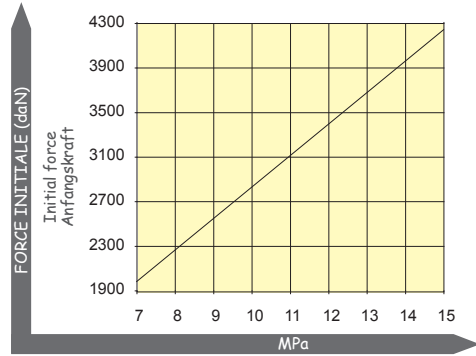
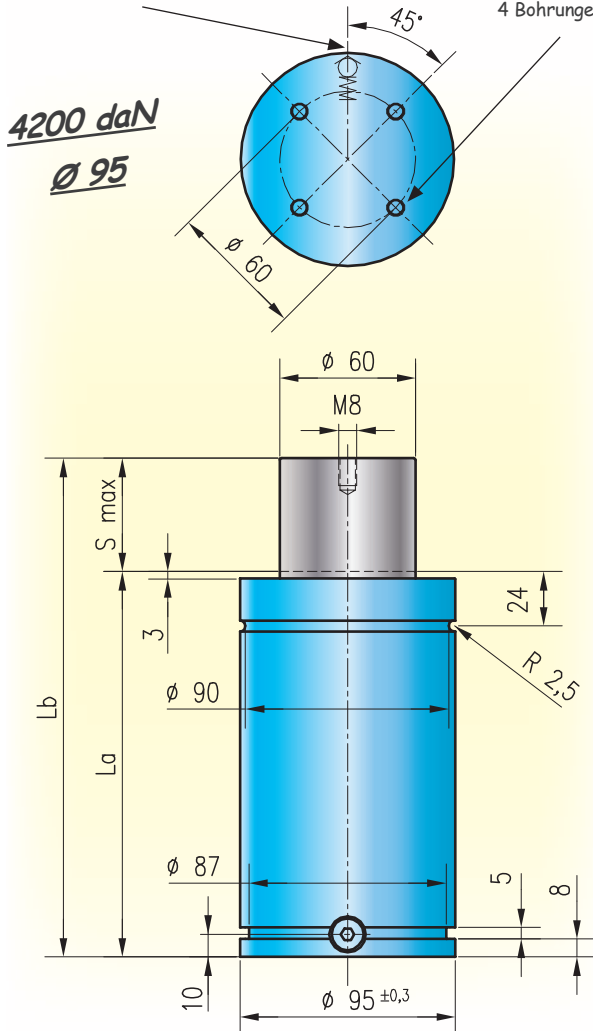

Force disponible lorsque la course de la tige varie.  
Pression de chargement: 15 MPa.  
Force available at different lengths of stroke.  
Charging pressure: 15 MPa.  
Bei Veränderung des Kolbenstangenhubs verfügbare Kraft.  
Ladedruck: 15 MPa.

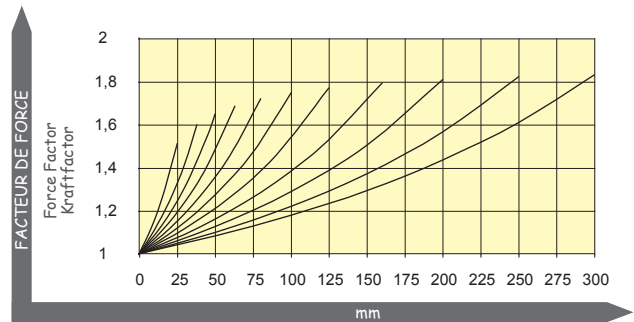

P max	P min	max	max	V max
15 Mpa	2 MPa	80 C°	0,0367/1°C	12 m/min

REF. 275 AR/P=42 S=160

275-42-160

\* sur demande / on request / auf Anfrage

Code	La mm	Lb mm	Fo daN	F daN	P MPa	V l	A cm <sup>2</sup>	Poids Kg	AR/P	S (max) mm	REF. 275
AR/P 42-25	145	170	4200 (±5%)	6398	15	0,209	28,26	5,75	42	25	*
AR/P 42-38	158	196		6761		0,287		6,15		38	*
AR/P 42-50	170	220		6973		0,36		6,53		50	*
AR/P 42-63	183	246		7132		0,438		6,91		63	*
AR/P 42-80	200	280		7276		0,541		7,25		80	*
AR/P 42-100	220	320		7393		0,662		8		100	*
AR/P 42-125	245	370		7492		0,813		8,15		125	*
AR/P 42-160	280	440		7585		1,024		9,24		160	*
AR/P 42-200	320	520		7655		1,266		10,31		200	*
AR/P 42-250	370	620		7712		1,568		11,9		250	*
AR/P 42-300	420	720		7752		1,87		14,87		300	*

# RESSORT A GAZ AR/P 65

GAS SPRING AR/P 65  
GASDRUCKFEDERN AR/P 65



Orifice de chargement/déchargement 1/8" Gaz  
Charging hole 1/8" Gas  
Befüllungsbohrung 1/8" Gas

4 Taraudages M10 Prof. 15 mm  
4 Holes M10 by 15 mm deep  
4 Bohrungen M10 15 mm tief

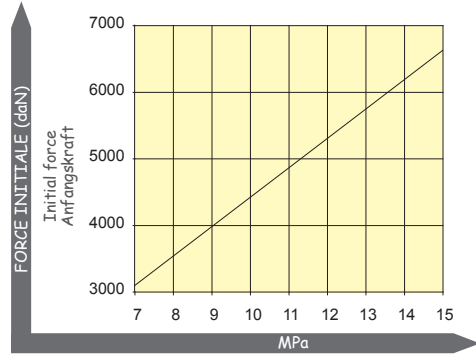
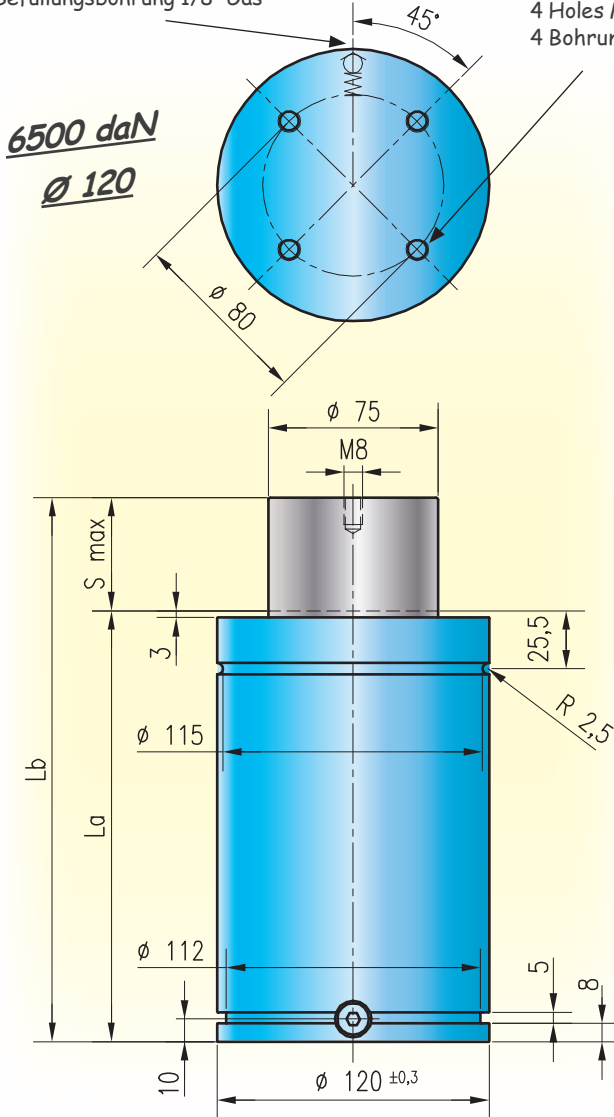

Force disponible lorsque la course de la tige varie.  
Pression de chargement: 15 MPa.  
Force available at different lengths of stroke.  
Charging pressure: 15 MPa.  
Bei Veränderung des Kolbenstangenhubs verfügbare Kraft.  
Ladedruck: 15 MPa.

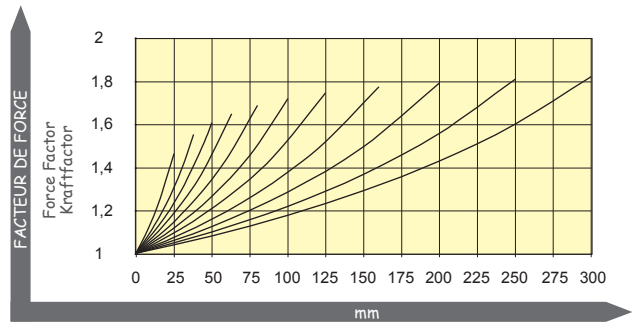

P max	P min	max		V max
15 Mpa	2 MPa	80 C°	0,0367/1°C	12 m/min

REF. 275 AR/P=65 S=160

275-65-160

\* sur demande / on request / auf Anfrage

Code	La mm	Lb mm	Fo daN	F daN	P MPa	V l	A cm <sup>2</sup>	Poids Kg	AR/P	S (max) mm	REF. 275
AR/P 65-25	165	190	6500 (±5%)	9663	15	0,35	44,15	12,01	65	25	*
AR/P 65-38	178	216		10257		0,473		12,85		*	
AR/P 65-50	190	240		10617		0,586		13,6		*	
AR/P 65-63	203	266		10894		0,709		14,5		*	
AR/P 65-80	220	300		11150		0,87		15,39		*	
AR/P 65-100	240	340		11361		1,058		16,48		*	
AR/P 65-125	265	390		11544		1,294		18,05		*	
AR/P 65-160	300	460		11716		1,625		19,83		*	
AR/P 65-200	340	540		11847		2,002		21,7		*	
AR/P 65-250	390	640		11956		2,474		23,85		*	
AR/P 65-300	440	740		12032		2,946		25,6		*	

# RESSORT A GAZ AR/C 5

GAS SPRING AR/C 5  
GASDRUCKFEDERN AR/C 5



Orifice de chargement/déchargement 1/8" Gaz  
Charging hole 1/8" Gas  
Befüllungsbohrung 1/8" Gas

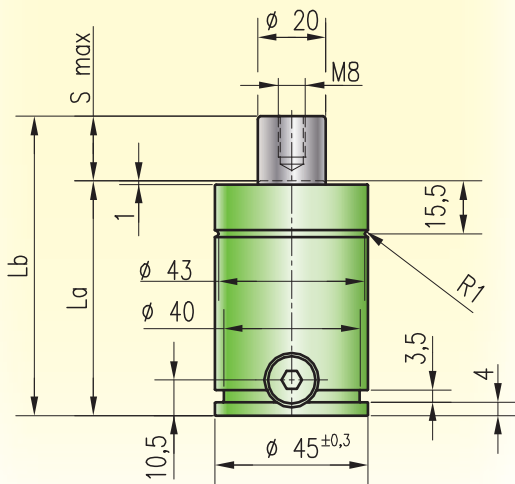
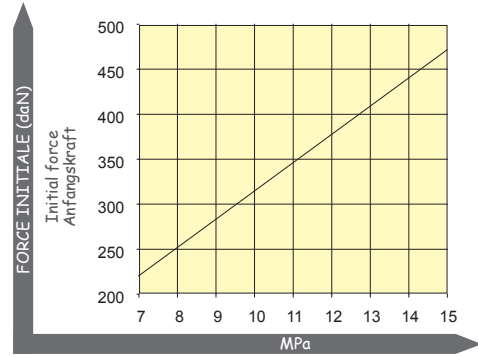
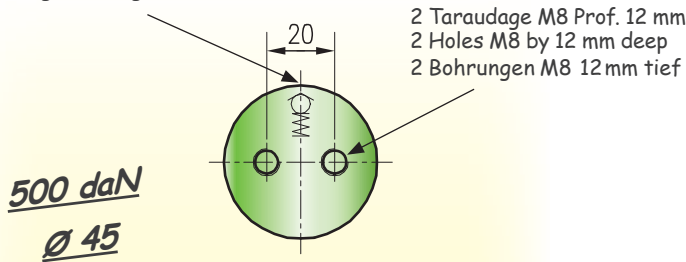

Force disponible lorsque la course de la tige varie.  
Pression de chargement: 15 MPa.  
Force available at different lengths of stroke.  
Charging pressure: 15 MPa.  
Bei Veränderung des Kolbenstangenhubs verfügbare Kraft.  
Ladedruck: 15 MPa.

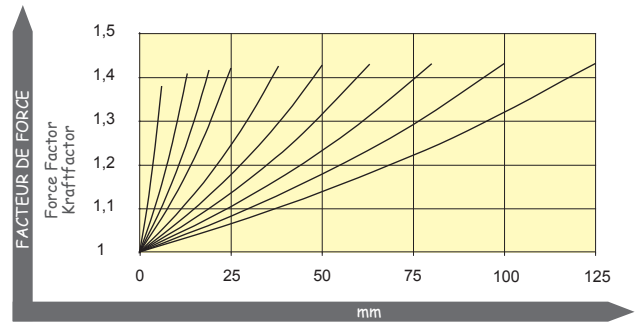

P max	P min	max	max	V max
15 Mpa	2 MPa	80 C°	0,0367/1°C	12 m/min

REF. 276 AR/C=5 S=38

276-5-38

\* sur demande / on request / auf Anfrage

Code	La mm	Lb mm	Fo daN	F daN	P MPa	V l	A cm <sup>2</sup>	Poids Kg	AR/C	S (max) mm	REF. 276
AR/C 5-6	56	62	500 (±5%)	648	15	0,006	3,14	0,5	5	6	*
AR/C 5-13	63	76		661		0,014		0,54		13	*
AR/C 5-19	69	88		665		0,02		0,59		19	*
AR/C 5-25	75	100		667		0,026		0,62		25	*
AR/C 5-38	88	126		670		0,04		0,71		38	*
AR/C 5-50	100	150		671		0,052		0,78		50	*
AR/C 5-63	113	176		671		0,066		0,88		63	*
AR/C 5-80	130	210		672		0,083		0,98		80	*
AR/C 5-100	150	250		672		0,104		1,12		100	*
AR/C 5-125	175	300		673		0,13		1,28		125	*



# RESSORT A GAZ AR/C 7,5

GAS SPRING AR/C 7,5  
GASDRUCKFEDERN AR/C 7,5



Orifice de chargement/déchargement 1/8" Gaz  
Charging hole 1/8" Gas  
Befüllungsbohrung 1/8" Gas

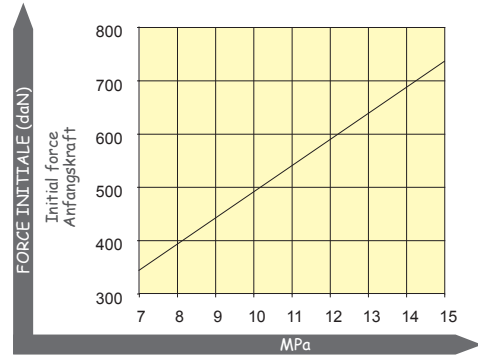
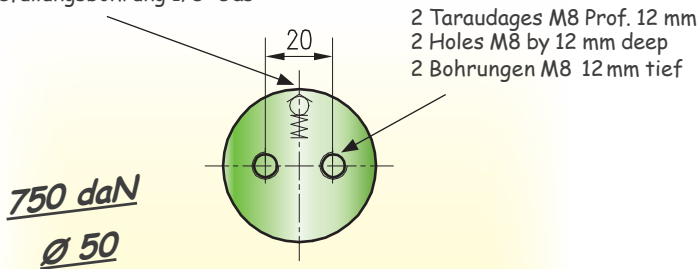

Force disponible lorsque la course de la tige varie.  
Pression de chargement: 15 MPa.

Force available at different lengths of stroke.

Charging pressure: 15 MPa.

Bei Veränderung des Kolbenstangenhubs verfügbare Kraft.  
Ladedruck: 15 MPa.

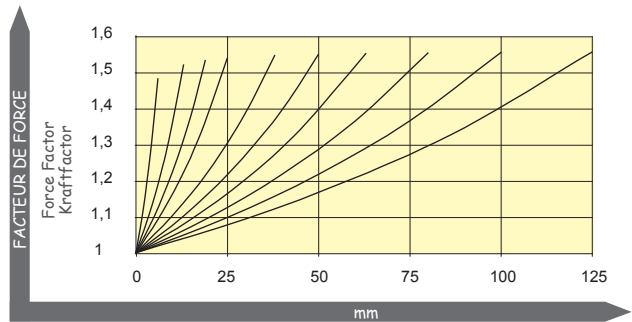
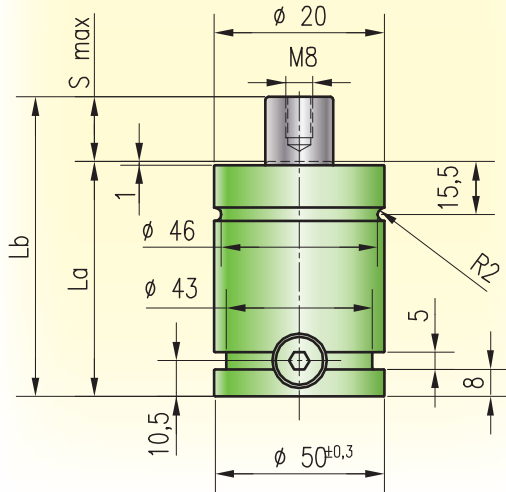

P max	P min	max		V max
15 Mpa	2 MPa	80 C°	0,0367/1°C	12 m/min

REF. 276 AR/C=7,5 S=38

276-7,5-38

\* sur demande / on request / auf Anfrage

Code	La mm	Lb mm	Fo daN	F daN	P MPa	V l	A cm <sup>2</sup>	Poids Kg	AR/C	S (max) mm	REF. 276
AR/C 7,5-6	56	62	750 (±5%)	1089	15	0,009	4,906	0,68	7,5	6	*
AR/C 7,5-13	63	76		1118		0,018		0,73			
AR/C 7,5-19	69	88		1126		0,026		0,8			
AR/C 7,5-25	75	100		1131		0,035		0,82			
AR/C 7,5-38	88	126		1136		0,052		0,92			
AR/C 7,5-50	100	150		1139		0,069		1,06			
AR/C 7,5-63	113	176		1140		0,087		1,12			
AR/C 7,5-80	130	210		1142		0,11		1,26			
AR/C 7,5-100	150	250		1143		0,137		1,39			
AR/C 7,5-125	175	300		1143		0,171		1,57		125	*



# RESSORT A GAZ AR/C 15

GAS SPRING AR/C 15  
GASDRUCKFEDERN AR/C 15



Orifice de chargement/déchargement 1/8" Gaz  
Charging hole 1/8" Gas  
Befüllungsbohrung 1/8" Gas

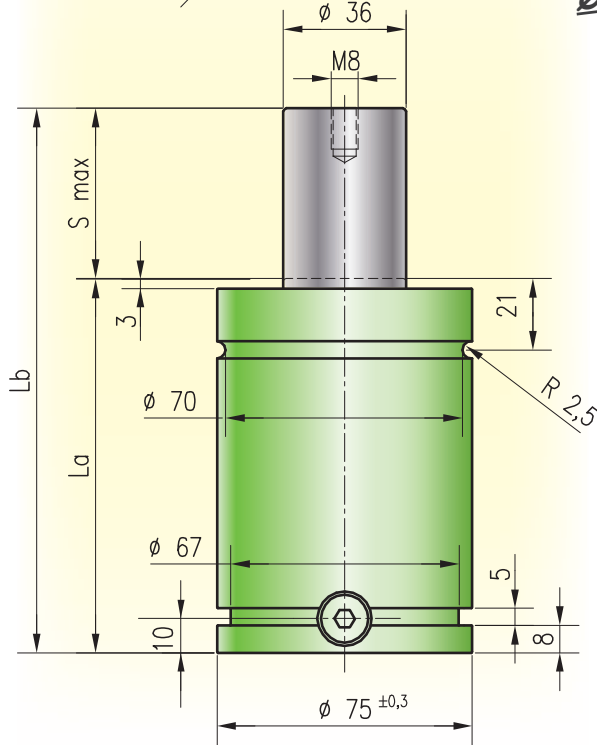
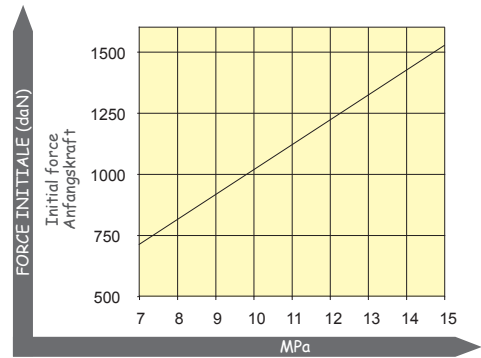
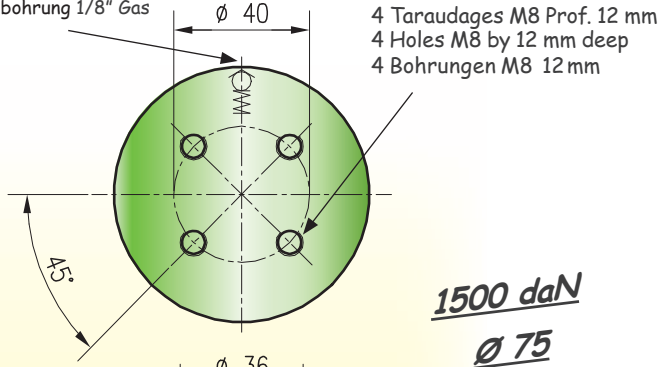

Force disponible lorsque la course de la tige varie.  
Pression de chargement: 15 MPa.  
Force available at different lengths of stroke.  
Charging pressure: 15 MPa.  
Bei Veränderung des Kolbenstangenhubs verfügbare Kraft.  
Ladedruck: 15 MPa.

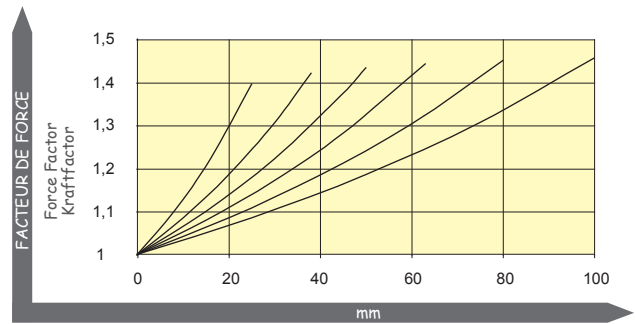

P max	P min	max		V max
15 Mpa	2 MPa	80 C°	0,0367/1°C	12 m/min

REF. 276 AR/C=15 S=80

276-15-80

\* sur demande / on request / auf Anfrage

Code	La mm	Lb mm	Fo daN	F daN	P MPa	V l	A cm <sup>2</sup>	Poids Kg	AR/C	S (max) mm	REF. 276
AR/C 15-25	85	110	1500 (±5%)	2129	15	0,089	10,17	2,05	15	25	*
AR/C 15-38	98	136		0,13		2,35		*			
AR/C 15-50	110	160		0,168		2,5		*			
AR/C 15-63	123	186		0,209		2,75		*			
AR/C 15-80	140	220		0,262		3,05		*			
AR/C 15-100	160	260		0,325		3,4		*			

# RESSORT A GAZ AR/C 30

GAS SPRING AR/C 30  
GASDRUCKFEDERN AR/C 30



**3000 daN**  
**Ø 95**

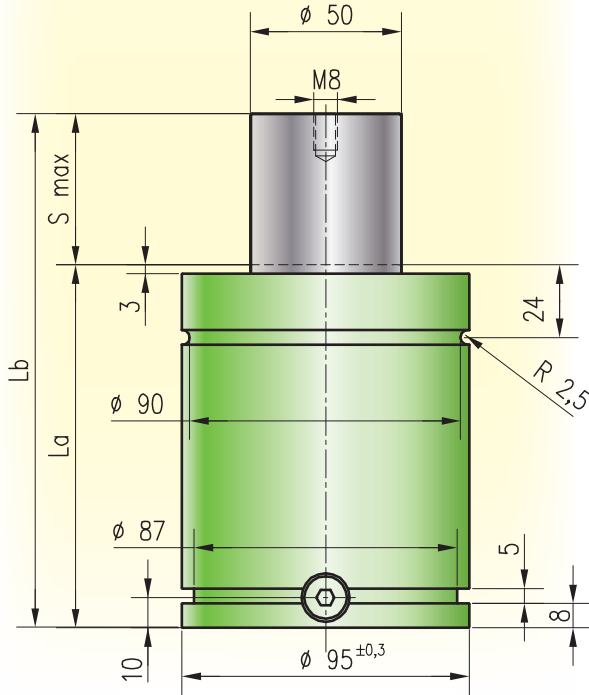
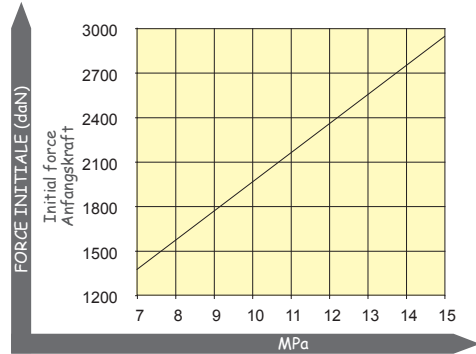
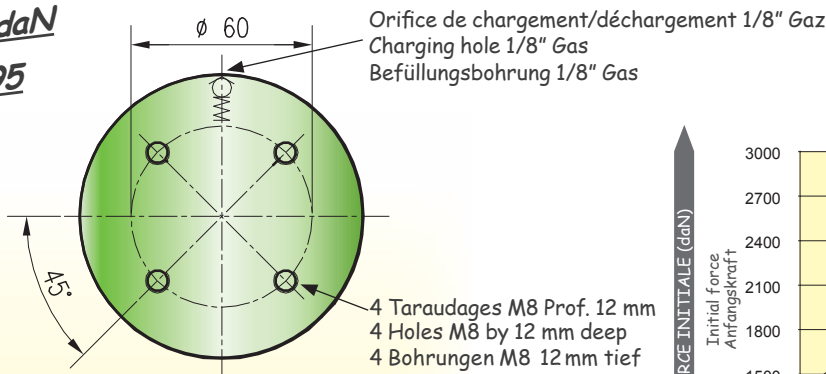

Force disponible lorsque la course de la tige varie.  
Pression de chargement: 15 MPa.  
Force available at different lengths of stroke.  
Charging pressure: 15 MPa.  
Bei Veränderung des Kolbenstangenhubs verfügbare Kraft.  
Ladedruck: 15 MPa.

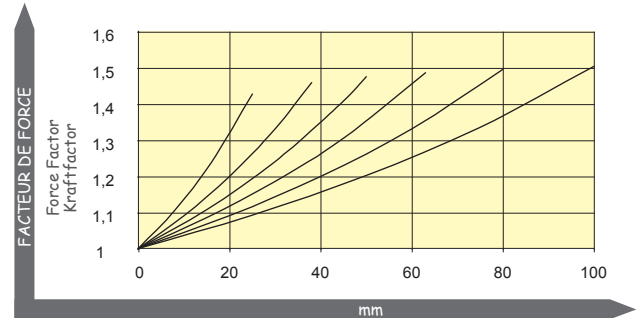

P max	P min	max		V max
15 Mpa	2 MPa	80 C°	0,0367/1°C	12 m/min

REF. 276 AR/C-30 S=50

276-30-50

\* sur demande / on request / auf Anfrage

Code	La mm	Lb mm	Fo daN	F daN	P MPa	V l	A cm <sup>2</sup>	Poids Kg	AR/C	S (max) mm	REF. 276
AR/C 30-25	95	120	3000 (±5%)	4199	15	0,164	19,62	3,95	30	25	*
AR/C 30-38	108	146		4291		0,237		4,37		*	
AR/C 30-50	120	170		4339		0,305		4,75		*	
AR/C 30-63	133	196		4372		0,378		5,2		*	
AR/C 30-80	150	230		4400		0,474		5,7		*	
AR/C 30-100	170	270		4421		0,587		6,4		*	

# RESSORT A GAZ AR/C 50

GAS SPRING AR/C 50  
GASDRUCKFEDERN AR/C 50

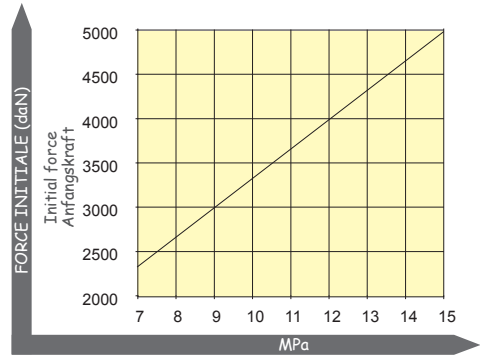
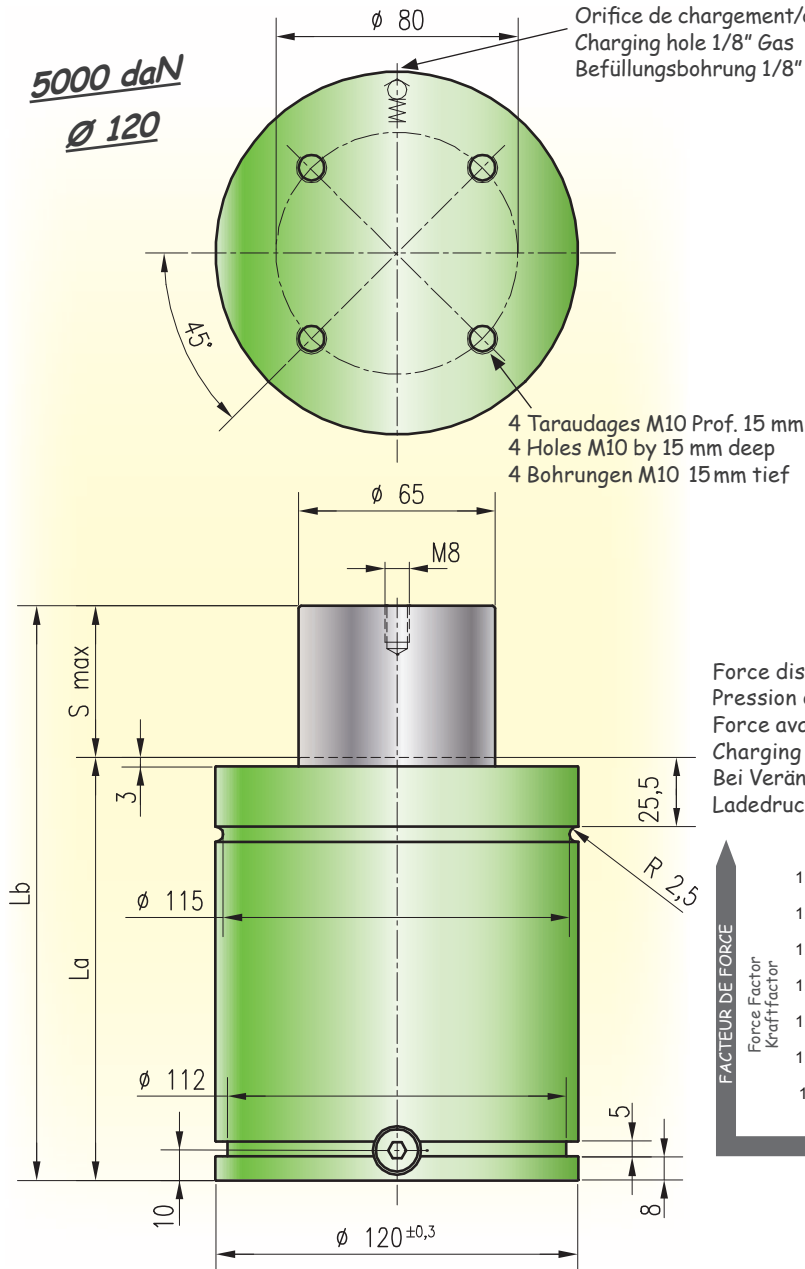

Force disponible lorsque la course de la tige varie.  
Pression de chargement: 15 MPa.  
Force available at different lengths of stroke.  
Charging pressure: 15 MPa.  
Bei Veränderung des Kolbenstangenhubs verfügbare Kraft.  
Ladedruck: 15 MPa.

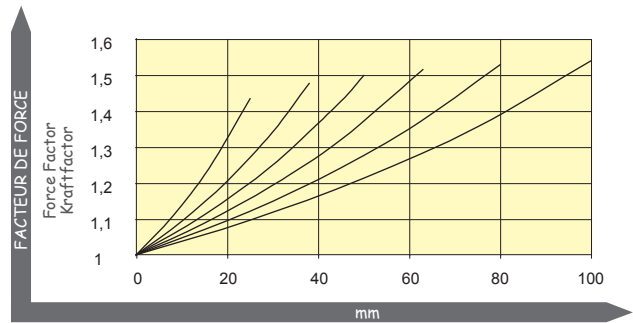

P max	P min	max	max	V max
15 Mpa	2 MPa	80 C°	0,0367/1°C	12 m/min

REF. 276 AR/C=50 S=100

276-50-100

\* sur demande / on request / auf Anfrage

Code	La mm	Lb mm	Fo daN	F daN	P MPa	V l	A cm <sup>2</sup>	Poids Kg	AR/C	S (max) mm	REF. 276
AR/C 50-25	115	140	5000 (±5%)	7125	15	0,274	33,16	5,1	50	25	*
AR/C 50-38	128	166		7336		0,391		5,6		38	*
AR/C 50-50	140	190		7448		0,499		6		50	*
AR/C 50-63	153	216		7527		0,616		6,5		63	*
AR/C 50-80	170	250		7596		0,768		7,2		80	*
AR/C 50-100	190	290		7649		0,948		8		100	*

## FIXATION FR POUR RESSORT A GAZ

MOUNT FR FOR GAS SPRING  
BEFESTIGUNG FR FÜR GASDRUCKFEDERN



VEP AUTOMATION



REF. 282  $\emptyset$  Ressort = 38



282-38

\* sur demande / on request / auf Anfrage

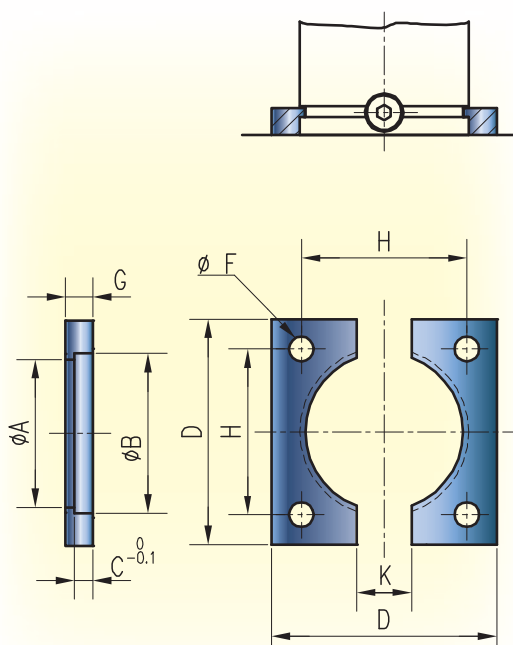

Code	Fixation FR	A	B	C	D	F	G	H	K	$\emptyset$ Ressort	REF. 282
4749	AR, KC	28,5	32,5	4	50	6,6	7	35	5	32	*
4751	AR, AR/P, KC, SR	34,5	38,5	4	55	6,6	7	40	5	38	*
4752	AR, AR/C, AR/P, KC	41,5	45,5	4	70	9	7	50	20	45	*
4754	AR, AR/C, AR/P, KC, SR	44,5	50,5	8	75	9	12	56,5	24	50	*
5958	KC, SR	57,5	63,5	8	85	11	12	63,5	24	63	*
4757	AR, AR/C, AR/P, KC, SR	68,5	75,5	8	100	11	12	73,5	24	75	*
4760	AR, AR/C, AR/P, KC, SR	88,5	95,5	8	120	13,5	12	92	24	95	*
4763	AR, AR/C, AR/P, KC, SR	113,5	120,5	8	140	13,5	12	109,5	24	120	*
4766	AR, SR	143,5	150,5	8	190	17,5	12	138	24	150	*
4770	AR	182	195,5	8	210	17,5	15	170	24	195	*

## FIXATION FRC POUR RESSORT A GAZ

MOUNT FRC FOR GAS SPRING  
BEFESTIGUNG FRC FÜR GASDRUCKFEDERN



VEP AUTOMATION



REF. 289  $\emptyset$  Ressort = 150



289-150

\* sur demande / on request / auf Anfrage

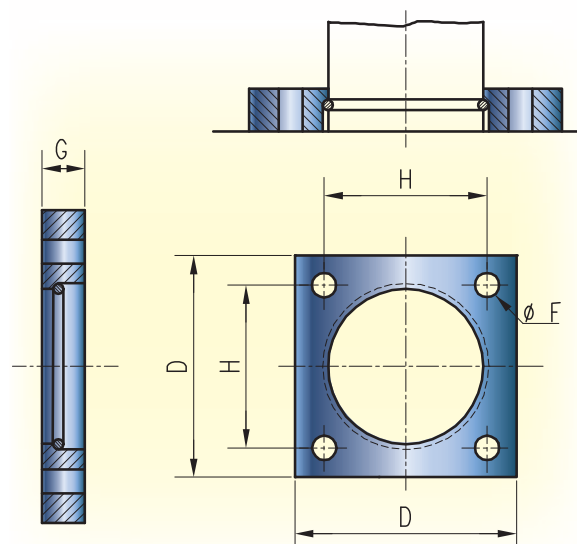

Code	Fixation FRC	D	F	G	H	$\emptyset$ Ressort	REF. 289
05922/C	SR	52	6,6	14,5	40	38	*
05923/C	SR	70	9	19,5	56,5	50	*
06237/C	SR	90	9	24,5	73,5	63	*
05924/C	SR	90	11	24,5	73,5	75	*
05925/C	SR	110	13	27,5	92	95	*
05926/C	SR	130	13	29,5	109,5	120	*
05927/C	SR	162	17,5	34,5	138	150	*

## FIXATION FA POUR RESSORT A GAZ

MOUNT FA FOR GAS SPRING  
BEFESTIGUNG FA FÜR GASDRUCKFEDERN

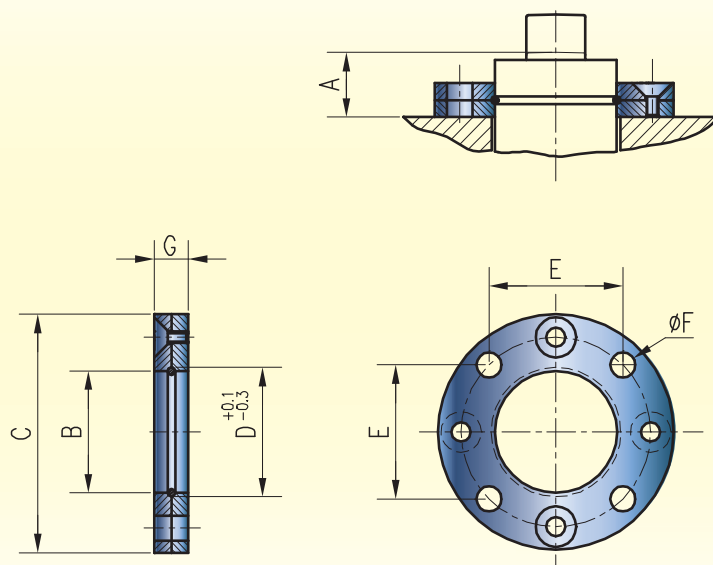

REF. 283 Ø Ressort = 38



283-38

\* sur demande / on request / auf Anfrage

Code	Fixation FA	A	B	C	D	E	F	G	Ø Ressort	REF. 283
05590/C	AR, KC	17	32,5	60	34	35	6,6	9	32	*
05589/C	AR, AR/P, KC, SR	17	38,5	68	40	40	6,6	9	38	*
05571/C	AR, AR/C, AR/P, KC	23	45,5	86	47	50	9	13	45	*
05573/C	AR, AR/C, AR/P, KC, KCR, SR	24	50,5	95	54	56,5	9	13	50	*
05772/C	KC, KCR, SR	27	63,5	122	67	73,5	11	16	63	*
05575/C	AR, AR/C, AR/P, KC, KCR, SR	29	75,5	122	80	73,5	11	16	75	*
05578/C	AR, AR/C, AR/P, KC, SR	33	95,5	150	100	92	13,5	18	95	*
05581/C	AR, AR/C, AR/P, KC, SR	36	120,5	175	125	109,5	13,5	21	120	*
05584/C	AR, SR	41	150,5	220	155	138	17,5	27	150	*
05587/C	AR	47	195,5	290	200	170	17,5	27	195	*

## FIXATION FAQ POUR RESSORT A GAZ

MOUNT FAQ FOR GAS SPRING  
BEFESTIGUNG FAQ FÜR GASDRUCKFEDERN

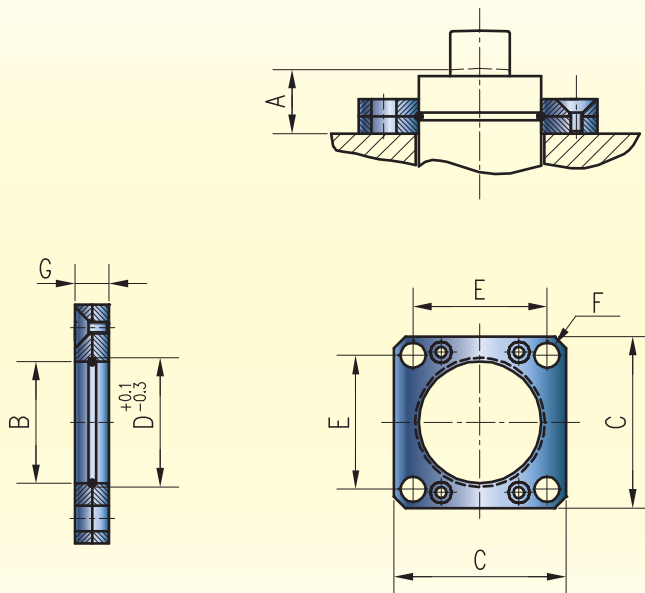
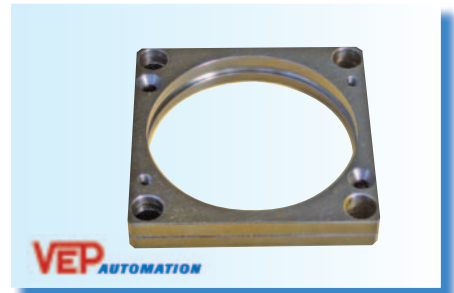

REF. 284 Ø Ressort = 38



284-38

\* sur demande / on request / auf Anfrage

Code	Fixation FAQ	A	B	C	D	E	F	G	Ø Ressort	REF. 284
05568/C	AR, AR/P, KC, SR	17	38,5	52	52	40	6	9	38	*
05567/C	AR, AR/C, AR/P, KC	23	45,5	64	47	50	9	13	45	*
05569/C	AR, AR/C, AR/P, KC, KCR, SR	24	50,5	70	54	56,5	9	13	50	*
06025/C	KC, KCR, SR	27	63,5	90	67	73,5	11	16	63	*
05576/C	AR, AR/C, AR/P, KC, KCR, SR	29	75,5	90	80	73,5	11	16	75	*
05579/C	AR, AR/C, AR/P, KC, SR	33	95,5	110	100	92	13,5	18	95	*
05582/C	AR, AR/C, AR/P, KC, SR	36	120,5	130	125	109,5	13,5	21	120	*
05585/C	AR, SR	41	150,5	162	155	138	17,5	27	150	*
05588/C	AR	47	195,5	210	200	170	17,5	27	195	*

## FIXATION FO POUR RESSORT A GAZ

MOUNT FO FOR GAS SPRING  
BEFESTIGUNG FO FÜR GASDRUCKFEDERN

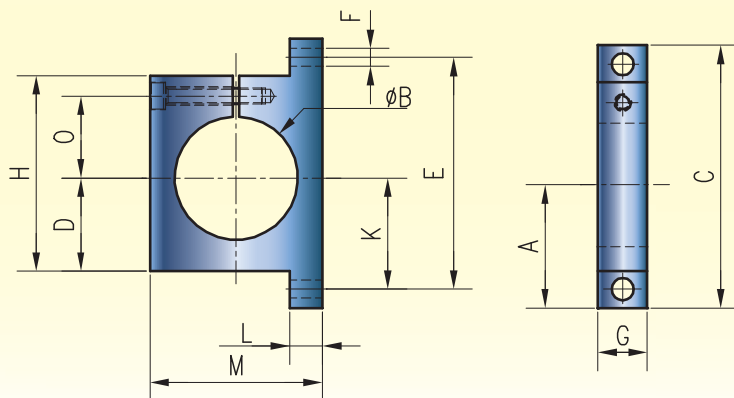
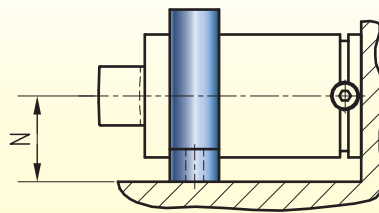
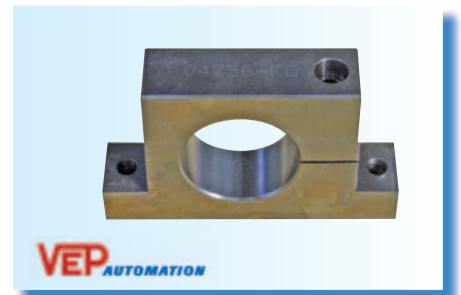

REF. 285 Ø Ressort = 38



285-38

\* sur demande / on request / auf Anfrage

Code	Fixation FO	A	B	C	D	E	F	G	H	K	L	M	N	O	VIS	Ø Ressort	REF. 285
06297/C	AR, AR/P	43	38	95	25	77	9	20	59	34	15	55	27,5	--	--	38	*
06024/C	AR, AR/C, AR/P, KC	46	45	100	28	82	9	30	64	37	15	60	30	--	--	45	*
04756/C	AR, AR/C, AR/P, KC, KCR, SR	60	50	130	40	110	9	30	90	50	20	80	40	37,5	M8	50	*
04759/C	AR, AR/C, AR/P, KC, KCR, SR	75	75	160	52,5	137	11	30	115	63,5	20	105	52,5	50	M10	75	*
04762/C	AR, AR/C, AR/P, KC, SR	92,5	95	195	67,5	170	13,5	30	145	80	20	125	62,5	62,5	M12	95	*
04765/C	AR, AR/C, AR/P, KC, SR	105	120	195	77,5	195	13,5	30	165	92,5	20	148	74	73,7	M12	120	*
04768/C	AR, SR	125	150	260	95	230	13,5	30	200	110	20	200	100	90	M12	150	*

## FIXATION FP POUR RESSORT A GAZ

MOUNT FP FOR GAS SPRING  
BEFESTIGUNG FP FÜR GASDRUCKFEDERN

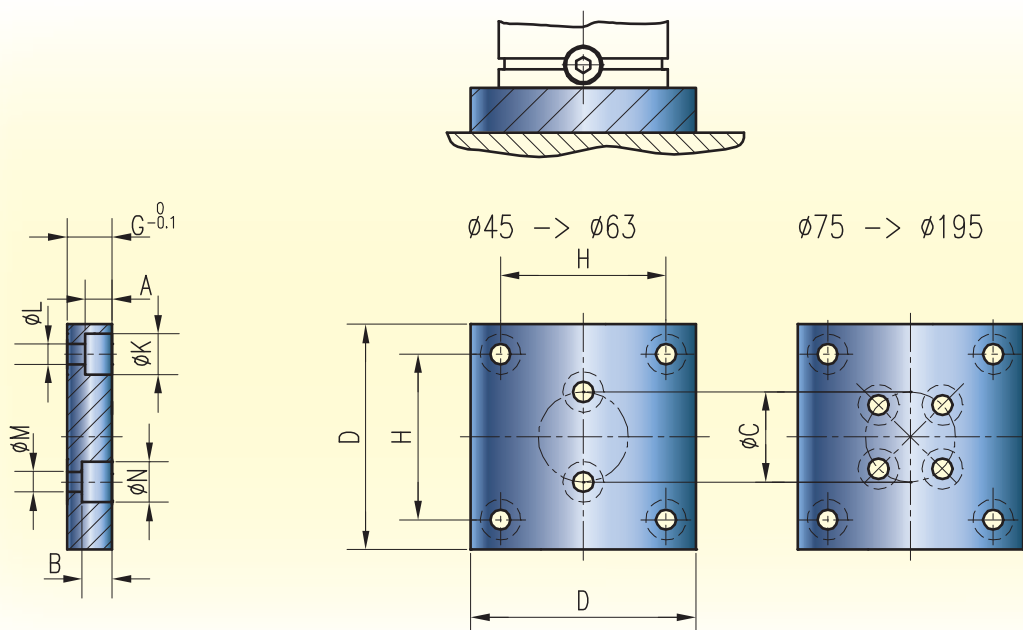

REF. 286  $\phi$  Ressort = 45



286-45

\* sur demande / on request / auf Anfrage

Code	Fixation FP	D	C	G	H	A	K	L	B	N	M	$\phi$ Ressort	REF. 286
05570/C	AR, AR/C, AR/P, KC	70	20	20	50	12	15	9	14	15	9	45	*
05572/C	AR, AR/C, AR/P, KC, KCR	75	20	20	56,5	12	15	9	14	15	9	50	*
05572/C	KC, KCR	75	20	20	56,5	12	15	9	14	15	9	63	*
05574/C	AR, AR/C, AR/P, KC, KCR	100	40	20	73,5	12	18	11	14	15	9	75	*
05577/C	AR, AR/C, AR/P, KC	120	60	20	92	13	20	13,5	14	15	9	95	*
05580/C	AR, AR/C, AR/P, KC	140	80	20	109,5	13	20	13,5	15	18	11	120	*
05583/C	AR	190	100	52	138	17	26	17,5	15	18	11	150	*
05586/C	AR	210	120	25	170	17	26	17,5	15	20	13,5	195	*

## FIXATION FPS POUR RESSORT A GAZ

MOUNT FPS FOR GAS SPRING  
BEFESTIGUNG FPS FÜR GASDRUCKFEDERN

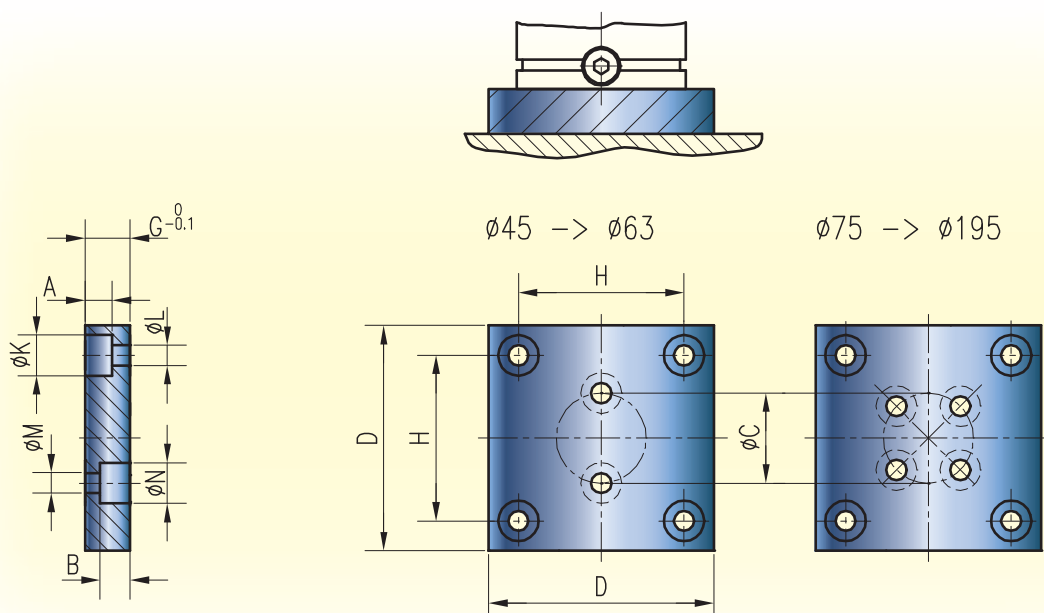

REF. 287 Ø Ressort = 45



287-45

\* sur demande / on request / auf Anfrage

Code	Fixation FPS	D	C	G	H	A	K	L	B	N	M	Ø Ressort	REF. 287
05917/C	AR, AR/C, AR/P, KC	70	20	20	50	12	15	9	14	15	9	45	*
05918/C	AR, AR/C, AR/P, KC, KCR	75	20	20	56,5	12	15	9	14	15	9	50	*
05918/C	KC, KCR	75	20	20	56,5	12	15	9	14	15	9	63	*
05919/C	AR, AR/C, AR/P, KC, KCR	100	40	20	73,5	12	18	11	14	15	9	75	*
05920/C	AR, AR/C, AR/P, KC	120	60	20	92	13	20	13,5	14	15	9	95	*
05921/C	AR, AR/C, AR/P, KC	140	80	20	109,5	13	20	13,5	15	18	11	120	*
05938/C	AR	190	100	52	138	17	26	17,5	15	18	11	150	*
05939/C	AR	210	120	25	170	17	26	17,5	15	20	13,5	195	*

## FIXATION FR1 POUR RESSORT A GAZ

MOUNT FR1 FOR GAS SPRING  
BEFESTIGUNG FR1 FÜR GASDRUCKFEDERN



VEP  
AUTOMATION

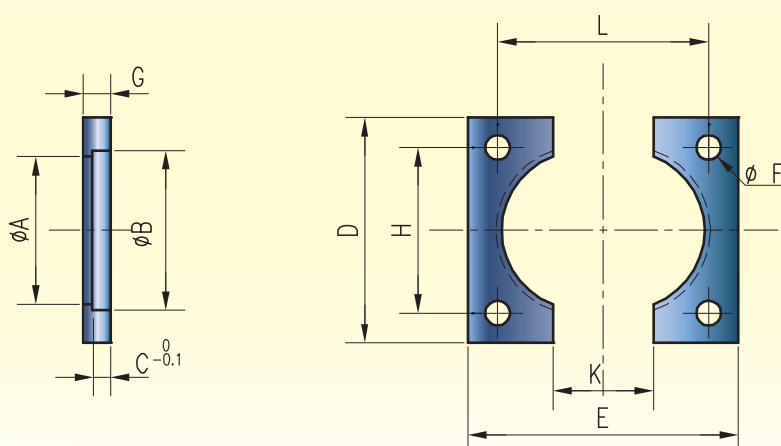
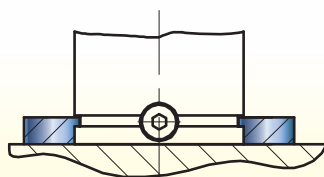

REF. 288 Ø Ressort = 45



288-45

\* sur demande / on request / auf Anfrage

Code	Fixation FR1	A	B	C	D	E	F	G	H	K	L	Ø Ressort	REF. 288
06181	AR, AR/C, AR/P, KC	41,5	45,5	4	40	70	9	7	27	25	57	45	*
06189	AR, AR/C, AR/P, KC, SR	44,5	50,5	8	45	75	9	12	32	25	62	50	*
06086	KC, SR	57,5	63,5	8	58	85	11	12	42	30	69	63	*
06190	AR, AR/C, AR/P, KC, SR	68,5	75,5	8	70	100	11	12	54	30	84	75	*
06047	AR, AR/C, AR/P, KC, SR	88,5	95,5	8	90	120	13	12	70	40	100	95	*
06191	AR, AR/C, AR/P, KC, SR	113,5	120,5	8	115	140	13,5	12	95	50	120	120	*
06192	AR, SR	143,5	150,5	8	145	190	17,5	12	120	60	165	150	*
06193	AR	188	195,5	8	190	210	17,5	13	145	80	185	195	*



## RESSORT DE COMPRESSION EN FIL A SECTION RECTANGULAIRE

RECTANGULAR WIRE DIE SPRING  
SYSTEM-DRUCKFEDER



### Séries

		Charge extra légère couleur « Violet» Réf.324
		Charge légère couleur « Vert» Réf.355
		Charge moyenne couleur « Bleu» Réf.356
		Charge forte couleur « Rouge» Réf.357
		Charge extra forte couleur « jaune» Réf.358
		Charge hyper forte couleur « bronze» Réf.359

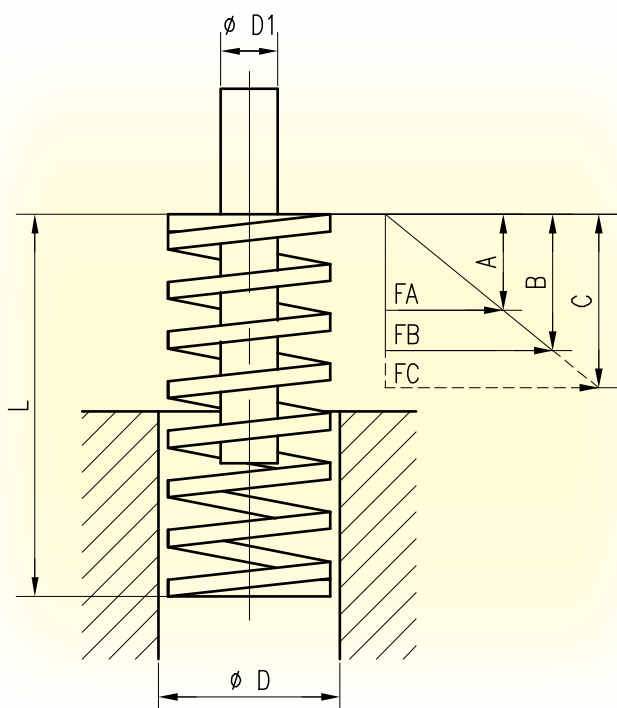

**L** =Longueur totale du ressort détendu.

**K** =Charge exprimée en newton pour obtenir une course d'un millimètre.

**A** =Charge et course recommandées pour une durée de vie optimale.

**B** =Charge et course maximales de travail.

**C** =Charge et course approximatives du ressort comprimé à bloc.

## RESSORT CHARGE EXTRA LEGERE COULEUR VIOLET

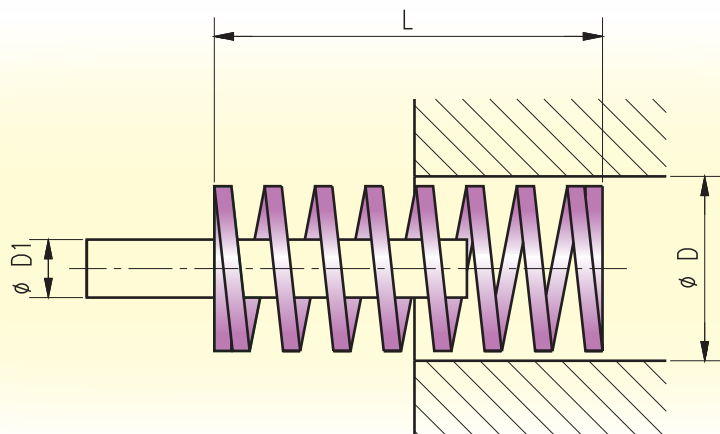
RECTANGULAR WIRE DIE SPRING PURPLE COLOUR LIGHT EXTRALOAD  
SYSTEM-DRUCKFEDER, PURPURROT

REF. 324 D=40 L=127 mm



324-40-127

K	A 35 %		B 50 %		C Approximatif		D1 mm	D mm	L mm	REF. 324
	N/mm	N	mm	N	mm	N				
32,1	280,875	8,75	401,25	12,5	449,4	14	10	20	25	
24,7	276,64	11,2	395,2	16	442,624	17,92			32	
20,7	275,31	13,3	393,3	19	440,496	21,28			38	
17,8	274,12	15,4	391,6	22	438,592	24,64			44	
15,3	273,105	17,85	390,15	25,5	436,968	28,56			51	
12,1	271,04	22,4	387,2	32	433,664	35,84			64	
10,2	271,32	26,6	387,6	38	434,112	42,56			76	
8,6	267,89	31,15	382,7	44,5	428,624	49,84			89	
7,5	267,75	35,7	382,5	51	428,4	57,12			102	
6,7	269,675	40,25	385,25	57,5	431,48	64,4			115	
6,1	271,145	44,45	387,35	63,5	433,832	71,12			127	
5,5	267,575	48,65	382,25	69,5	428,12	77,84			139	
5,1	271,32	53,2	387,6	76	434,112	85,12			152	
2,5	266,875	106,75	381,25	152,5	427	170,8			305	
52,7	461,125	8,75	658,75	12,5	737,8	14	12,5	25	25	
40	448	11,2	640	16	716,8	17,92			32	
33,3	442,89	13,3	632,7	19	708,624	21,28			38	
28,6	440,44	15,4	629,2	22	704,704	24,64			44	
24,7	440,895	17,85	629,85	25,5	705,432	28,56			51	
19,4	434,56	22,4	620,8	32	695,296	35,84			64	
16,3	433,58	26,6	619,4	38	693,728	42,56			76	
13,9	432,985	31,15	618,55	44,5	692,776	49,84			89	
12,1	431,97	35,7	617,1	51	691,152	57,12			102	
10,8	434,7	40,25	621	57,5	695,52	64,4			115	
9,8	435,61	44,45	622,3	63,5	696,976	71,12			127	
8,9	432,985	48,65	618,55	69,5	692,776	77,84			139	
8,1	430,92	53,2	615,6	76	689,472	85,12			152	
6,9	429,87	62,3	614,1	89	687,792	99,68			178	
6,1	433,405	71,05	619,15	101,5	693,448	113,68	203			
4	427	106,75	610	152,5	683,2	170,8	305			

## RESSORT CHARGE EXTRA LEGERE COULEUR VIOLET

RECTANGULAR WIRE DIE SPRING PURPLE COLOUR LIGHT EXTRALOAD  
SYSTEM-DRUCKFEDER, PURPURROT

K	A 35 %		B 50 %		C Approximatif		D1 mm	D mm	L mm	REF. 324		
	N/mm	N	mm	N	mm	N					mm	
43,8	582,54	13,3	832,2	19	932,064	21,28	16	32	38			
37,5	577,5	15,4	825	22	924	24,64			44			
32,3	576,555	17,85	823,65	25,5	922,488	28,56			51			
25,4	568,96	22,4	812,8	32	910,336	35,84			64			
21,3	566,58	26,6	809,4	38	906,528	42,56			76			
18,1	563,815	31,15	805,45	44,5	902,104	49,84			89			
15,8	564,06	35,7	805,8	51	902,496	57,12			102			
13,9	559,475	40,25	799,25	57,5	895,16	64,4			115			
12,6	560,07	44,45	800,1	63,5	896,112	71,12			127			
11,4	554,61	48,65	792,3	69,5	887,376	77,84			139			
10,5	558,6	53,2	798	76	893,76	85,12			152			
8,9	554,47	62,3	792,1	89	887,152	99,68			178			
7,8	554,19	71,05	791,7	101,5	886,704	113,68			203			
6,2	551,18	88,9	787,4	127	881,888	142,24			254			
5,2	555,1	106,75	793	152,5	888,16	170,8			305			
50,8	906,78	17,85	1295,4	25,5	1450,848	28,56			20	40	51	
39,7	889,28	22,4	1270,4	32	1422,848	35,84	64					
33,1	880,46	26,6	1257,8	38	1408,736	42,56	76					
28,1	875,315	31,15	1250,45	44,5	1400,504	49,84	89					
24,5	874,65	35,7	1249,5	51	1399,44	57,12	102					
21,6	869,4	40,25	1242	57,5	1391,04	64,4	115					
19,5	866,775	44,45	1238,25	63,5	1386,84	71,12	127					
17,8	865,97	48,65	1237,1	69,5	1385,552	77,84	139					
16,3	867,16	53,2	1238,8	76	1387,456	85,12	152					
13,8	859,74	62,3	1228,2	89	1375,584	99,68	178					
12,1	859,705	71,05	1228,15	101,5	1375,528	113,68	203					
9,7	862,33	88,9	1231,9	127	1379,728	142,24	254					
8	854	106,75	1220	152,5	1366,4	170,8	305					
80,2	1796,48	22,4	2566,4	32	2874,368	35,84	25	50			64	
66,9	1779,54	26,6	2542,2	38	2847,264	42,56					76	
56,6	1763,09	31,15	2518,7	44,5	2820,944	49,84					89	
49,3	1760,01	35,7	2514,3	51	2816,016	57,12			102			
43,5	1750,875	40,25	2501,25	57,5	2801,4	64,4			115			
39,3	1746,885	44,45	2495,55	63,5	2795,016	71,12			127			
35,8	1741,67	48,65	2488,1	69,5	2786,672	77,84			139			
32,8	1744,96	53,2	2492,8	76	2791,936	85,12			152			
27,8	1731,94	62,3	2474,2	89	2771,104	99,68			178			
24,2	1719,41	71,05	2456,3	101,5	2751,056	113,68			203			
19,2	1706,88	88,9	2438,4	127	2731,008	142,24			254			
16	1708	106,75	2440	152,5	2732,8	170,8			305			

## RESSORT CHARGE LEGERE COULEUR VERT

RECTANGULAR WIRE DIE SPRING GREEN COLOUR LIGHT LOAD  
SYSTEM-DRUCKFEDER, GRÜN

ISO 10243



K	A 30 %		B 40 %		C Approximatif		D1 mm	D mm	L mm	REF. 355
	N	mm	N	mm	N	mm				
10	75	7,5	100	10	130	13	5	10	25	
8,5	82	9,6	109	12,8	136	16			32	
6,8	78	11,4	103	15,2	136	20			38	
6	79	13,2	106	17,6	144	24			44	
5	77	15,3	102	20,4	135	27			51	
4,3	83	19,2	110	25,6	151	35			64	
3,2	73	22,8	97	30,4	125	39			76	
1,1	101	91,5	134	122	169	154			305	
17,9	134	7,5	179	10	233	13			25	
16,4	157	9,6	210	12,8	279	17			32	
13,6	155	11,4	207	15,2	286	21	38			
12,1	160	13,2	213	17,6	315	26	44			
11,4	174	15,3	233	20,4	331	29	51			
9,3	179	19,2	238	25,6	344	37	64			
7,1	162	22,8	216	30,4	298	42	76			
5,4	144	26,7	192	35,6	270	50	89			
4,6	141	30,6	188	40,8	267	58	102			
1,4	128	91,5	171	122	227	162	305			
23,4	176	7,5	234	10	304	13	25			
22,9	220	9,6	293	12,8	389	17	32			
19,3	220	11,4	293	15,2	386	20	38			
17,1	226	13,2	301	17,6	428	25	44			
15,7	240	15,3	320	20,4	424	27	51			
10,7	205	19,2	274	25,6	385	36	64			
10	228	22,8	304	30,4	430	43	76			
8,6	230	26,7	306	35,6	447	52	89			
7,8	239	30,6	318	40,8	452	58	102			
2,5	229	91,5	305	122	415	166	305			
55,8	419	7,5	558	10	725	13	25			
45	432	9,6	576	12,8	765	17	32			
33,3	380	11,4	506	15,2	666	20	38			
30	396	13,2	528	17,6	720	24	44			
24,5	375	15,3	500	20,4	662	27	51			
20	384	19,2	512	25,6	700	35	64			
16	365	22,8	486	30,4	640	40	76			
14	374	26,7	498	35,6	686	49	89			
12	367	30,6	490	40,8	660	55	102			
10,9	376	34,5	501	46	676	62	115			
9,5	362	38,1	483	50,8	675	71	127			
8,4	350	41,7	467	55,6	638	76	139			
7,5	342	45,6	456	60,8	608	81	152			
4	366	91,5	488	122	672	168	305			
100	750	7,5	1000	10	1200	12	25			
80,3	771	9,6	1028	12,8	1285	16	32			
62	707	11,4	942	15,2	1178	19	38			
52,9	698	13,2	931	17,6	1164	22	44			
44	673	15,3	898	20,4	1100	25	51			
35,2	676	19,2	901	25,6	1197	34	64			
28	638	22,8	851	30,4	1064	38	76			
24	641	26,7	854	35,6	1152	48	89			
21,1	646	30,6	861	40,8	1139	54	102			
18,7	645	34,5	860	46	1141	61	115			
16,7	636	38,1	848	50,8	1152	69	127			
15,3	638	41,7	851	55,6	1148	75	139			
14	638	45,6	851	60,8	1134	81	152			
12,5	668	53,4	890	71,2	1200	96	178			
10,4	633	60,9	844	81,2	1144	110	203			
7	641	91,5	854	122	1176	168	305			

# RESSORT CHARGE LEGERE COULEUR VERT

RECTANGULAR WIRE DIE SPRING GREEN COLOUR LIGHT LOAD SYSTEM-DRUCKFEDER, GRÜN



ISO 10243

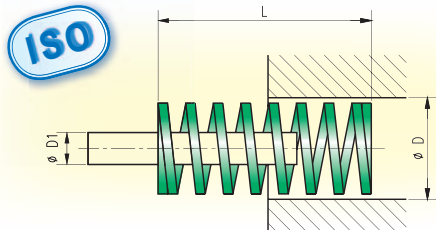

REF. 355 D=40 L =127 mm



355-40-127

K	A 30 %		B 40 %		C Approximatif		D1 mm	D mm	L mm	REF. 355		
	N/mm	N	mm	N	mm	N					mm	
94	1072	11,4	1429	15,2	1692	18	16	32	38			
79,5	1049	13,2	1399	17,6	1749	22			44			
67	1025	15,3	1367	20,4	1675	25			51			
53	1018	19,2	1357	25,6	1802	34			64			
44	1003	22,8	1338	30,4	1760	40			76			
37,2	993	26,7	1324	35,6	1786	48			89			
32	979	30,6	1306	40,8	1760	55			102			
29	1001	34,5	1334	46	1827	63			115			
25	953	38,1	1270	50,8	1725	69			127			
23	959	41,7	1279	55,6	1771	77			139			
21,5	980	45,6	1307	60,8	1742	81			152			
18,2	972	53,4	1296	71,2	1729	95			178			
15,8	962	60,9	1283	81,2	1770	112			203			
12,5	953	76,2	1270	101,6	1788	143			254			
10,3	942	91,5	1257	122	1803	175			305			
92	1408	15,3	1877	20,4	2300	25	20	40	51			
73	1402	19,2	1869	25,6	2409	33			64			
63	1436	22,8	1915	30,4	2457	39			76			
51	1362	26,7	1816	35,6	2397	47			89			
43	1316	30,6	1754	40,8	2322	54			102			
39,6	1366	34,5	1822	46	2416	61			115			
37	1410	38,1	1880	50,8	2442	66			127			
32	1334	41,7	1779	55,6	2432	76			139			
28	1277	45,6	1702	60,8	2268	81			152			
25,2	1346	53,4	1794	71,2	2344	93			178			
22,7	1382	60,9	1843	81,2	2497	110			203			
17	1295	76,2	1727	101,6	2312	136			254			
14,8	1354	91,5	1806	122	2412	163			305			
156	2995	19,2	3994	25,6	4836	31			25	50	64	
125	2850	22,8	3800	30,4	4500	36					76	
109	2910	26,7	3880	35,6	4796	44	89					
94	2876	30,6	3835	40,8	4606	49	102					
81	2795	34,5	3726	46	4860	60	115					
71	2705	38,1	3607	50,8	4544	64	127					
66,5	2773	41,7	3697	55,6	4655	70	139					
60	2736	45,6	3648	60,8	4620	77	152					
52	2777	53,4	3702	71,2	4888	94	178					
44	2680	60,9	3573	81,2	4620	105	203					
38,2	2624	68,7	3499	91,6	4813	126	229					
35	2667	76,2	3556	101,6	4795	137	254					
28,5	2608	91,5	3477	122	4788	168	305					
189	4309	22,8	5746	30,4	7182	38	38	63			76	
158	4219	26,7	5625	35,6	7110	45					89	
131	4009	30,6	5345	40,8	6812	52			102			
116	4002	34,5	5336	46	6960	60			115			
103	3924	38,1	5232	50,8	6489	63			127			
84,3	3844	45,6	5125	60,8	6575	78			152			
71,5	3818	53,4	5091	71,2	6364	89			178			
61,7	3758	60,9	5010	81,2	6664	108			203			
47	3581	76,2	4775	101,6	6439	137			254			
38,2	3495	91,5	4660	122	6227	163			305			

## RESSORT CHARGE MOYENNE COULEUR BLEU

RECTANGULAR WIRE DIE SPRING BLUE COLOUR MEDIUM LOAD  
SYSTEM-DRUCKFEDER, BLAU

ISO 10243



K	A 25 %		B 37,5 %		C Approximatif		D1 mm	D mm	L mm	REF. 356		
	N	mm	N	mm	N	mm						
16	100	6,3	150	9,4	192	12	5 Section du fil 1,8 x 1,2	10	25			
13	104	8	156	12	182	14			32			
11,9	113	9,5	170	14,3	226	19			38			
10,3	113	11	170	16,5	237	23			44			
8,9	113	12,8	170	19,1	240	27			51			
7,5	120	16	180	24	233	31			64			
5,3	101	19	151	28,5	196	37			76			
1,6	122	76,3	183	114,4	219	137			305			
30	188	6,3	281	9,4	300	10			6,3 Section du fil 2,5 x 1,7	12,5	25	
24,8	198	8	298	12	322	13					32	
21,4	203	9,5	305	14,3	342	16	38					
18,5	204	11	305	16,5	370	20	44					
15,5	198	12,8	296	19,1	388	25	51					
12,1	194	16	290	24	339	28	64					
10,2	194	19	291	28,5	347	34	76					
8,4	187	22,3	280	33,4	344	41	89					
7,1	181	25,5	272	38,3	327	46	102					
2,1	160	76,3	240	114,4	269	128	305					
49,4	309	6,3	463	9,4	543	11	8 Section du fil 3,2 x 2	16	25			
37,1	297	8	445	12	557	15			32			
33,9	322	9,5	483	14,3	610	18			38			
30	330	11	495	16,5	660	22			44			
26,4	337	12,8	505	19,1	634	24			51			
20,5	328	16	492	24	656	32			64			
17,8	338	19	507	28,5	641	36			76			
15,2	338	22,3	507	33,4	654	43			89			
13,5	344	25,5	516	38,3	635	47			102			
4,8	366	76,3	549	114,4	667	139			305			
98	613	6,3	919	9,4	980	10	10 Section du fil 4 x 2,4	20	25			
72,6	581	8	871	12	944	13			32			
56	532	9,5	798	14,3	896	16			38			
47,5	523	11	784	16,5	903	19			44			
41,7	532	12,8	798	19,1	876	21			51			
32,3	517	16	775	24	904	28			64			
25,1	477	19	715	28,5	828	33			76			
22	490	22,3	734	33,4	902	41			89			
19,8	505	25,5	757	38,3	950	48			102			
18,1	520	28,8	781	43,1	996	55			115			
16,6	527	31,8	791	47,6	1013	61	127					
15,1	525	34,8	787	52,1	1012	67	139					
13,2	502	38	752	57	977	74	152					
6,1	465	76,3	698	114,4	891	146	305					
147	919	6,3	1378	9,4	1617	11	12,5 Section du fil 5,3 x 3,1	25	25			
118	944	8	1416	12	1534	13			32			
93	884	9,5	1325	14,3	1674	18			38			
80,8	889	11	1333	16,5	1697	21			44			
68,6	875	12,8	1312	19,1	1578	23			51			
53	848	16	1272	24	1590	30			64			
43,2	821	19	1231	28,5	1512	35			76			
38,2	850	22,3	1275	33,4	1643	43			89			
33	842	25,5	1262	38,3	1617	49			102			
28	805	28,8	1208	43,1	1568	56			115			
25,9	822	31,8	1233	47,6	1554	60	127					
23,2	806	34,8	1209	52,1	1508	65	139					
20,8	790	38	1186	57	1477	71	152					
17,8	792	44,5	1188	66,8	1513	85	178					
15,8	802	50,8	1203	76,1	1517	96	203					
10,2	778	76,3	1167	114,4	1530	150	305					



# RESSORT CHARGE MOYENNE COULEUR BLEU

RECTANGULAR WIRE DIE SPRING BLUE COLOUR MEDIUM LOAD  
SYSTEM-DRUCKFEDER, BLAU



ISO 10243

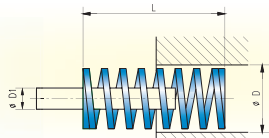

REF. 356 D=40 L=127 mm



356-40-127

K N/mm	A 25 %		B 37,5 %		C Approximatif		D1 mm	D mm	L mm	REF. 356
	N	mm	N	mm	N	mm				
185	1758	9,5	2636	14,3	3145	17	16	32	38	
158	1738	11	2607	16,5	3002	19			44	
134	1709	12,8	2563	19,1	3082	23			51	
99	1584	16	2376	24	2970	30			64	
80,5	1530	19	2294	28,5	2737	34			76	
69,1	1537	22,3	2306	33,4	2902	42			89	
58,8	1499	25,5	2249	38,3	2764	47			102	
51,5	1481	28,8	2221	43,1	2833	55			115	
44,8	1422	31,8	2134	47,6	2733	61			127	
42,3	1470	34,8	2205	52,1	2876	68			139	
37,8	1436	38	2155	57	2835	75			152	
32,5	1446	44,5	2169	66,8	2893	89			178	
28,9	1467	50,8	2200	76,1	2919	101			203	
21,4	1359	63,5	2038	95,3	2654	124			254	
18,3	1395	76,3	2093	114,4	2745	150			305	
182	2315	12,8	3473	19,1	3814	21	20	40	51	
140	2240	16	3360	24	3920	28			64	
108	2052	19	3078	28,5	3564	33			76	
90,7	2018	22,3	3027	33,4	3719	41			89	
81	2066	25,5	3098	38,3	3645	45			102	
71,8	2064	28,8	3096	43,1	3734	52			115	
62,7	1991	31,8	2986	47,6	3699	59			127	
57,5	1998	34,8	2997	52,1	3795	66			139	
51,6	1961	38	2941	57	3664	71			152	
47,5	1900	40	2850	60	3420	72			160	
44,1	1962	44,5	2944	66,8	3660	83			178	
36,7	1863	50,8	2794	76,1	3450	94			203	
30,1	1911	63,5	2867	95,3	3431	114			254	
24,6	1876	76,3	2814	114,4	3641	148			305	
209	3344	16	5016	24	6270	30			25	50
168	3192	19	4788	28,5	6048	36	76			
140	3115	22,3	4673	33,4	6020	43	89			
119	3035	25,5	4552	38,3	5712	48	102			
106	3048	28,8	4571	43,1	5830	55	115			
97	3080	31,8	4620	47,6	6111	63	127			
87	3023	34,8	4535	52,1	5742	66	139			
80	3040	38	4560	57	5760	72	152			
76	3040	40	4560	60	5928	78	160			
69,5	3093	44,5	4639	66,8	5908	85	178			
59,8	3035	50,8	4552	76,1	5681	95	203			
50,9	2914	57,3	4371	85,9	5803	114	229			
43,9	2788	63,5	4181	95,3	5488	125	254			
38,6	2943	76,3	4415	114,4	5790	150	305			
312	5928	19	8892	28,5	9360	30	38	63		
260	5785	22,3	8678	33,4	9880	38			89	
221	5636	25,5	8453	38,3	9503	43			102	
187	5376	28,8	8064	43,1	9350	50			115	
168	5334	31,8	8001	47,6	8736	52			127	
136	5168	38	7752	57	9112	67			152	
128	5120	40	7680	60	8960	70			160	
114	5073	44,5	7610	66,8	8892	78			178	
100	5075	50,8	7613	76,1	8800	88			203	
89,2	5107	57,3	7660	85,9	9098	102			229	
78,4	4978	63,5	7468	95,3	9016	115			254	
64,7	4933	76,3	7400	114,4	8670	134			305	
62,8	4946	78,8	7418	118	9043	144			315	
48,5	4850	100	7275	150	9555	197			400	

## RESSORT CHARGE FORTE COULEUR ROUGE

RECTANGULAR WIRE DIE SPRING RED COLOUR HEAVY LOAD  
SYSTEM-DRUCKFEDER, ROT

ISO 10243



K	A 20 %		B 30 %		C Approximatif		D1 mm	D mm	L mm	REF. 357
	N	mm	N	mm	N	mm				
22,1	111	5	166	7,5	199	9	5	10	25	
17,5	112	6,4	168	9,6	210	12			32	
17,1	130	7,6	195	11,4	257	15			38	
15	132	8,8	198	13,2	255	17			44	
12,8	131	10,2	196	15,3	269	21			51	
10,7	137	12,8	205	19,2	278	26	Section du fil 1,9 x 1,5	64		
7,5	114	15,2	171	22,8	233	31		76		
2,1	128	61	192	91,5	256	122		305		
42,1	211	5	316	7,5	379	9		6,3	25	
33,2	212	6,4	319	9,6	432	13			32	
29,3	223	7,6	334	11,4	440	15	38			
24,6	216	8,8	325	13,2	443	18	44			
19,6	200	10,2	300	15,3	392	20	51			
15	192	12,8	288	19,2	390	26	Section du fil 2,4 x 2	64		
13,2	201	15,2	301	22,8	396	30		76		
11,4	203	17,8	304	26,7	399	35		89		
6,4	192	20,4	287	30,6	385	41		102		
2,8	171	61	256	91,5	344	123		305		
75,7	379	5	568	7,5	681	9	8	16	25	
52,8	338	6,4	507	9,6	739	14			32	
48,5	369	7,6	553	11,4	825	17			38	
42,8	377	8,8	565	13,2	856	20			44	
37,1	378	10,2	568	15,3	779	21			51	
30,3	388	12,8	582	19,2	848	28	Section du fil 3 x 2,4	64		
25,7	391	15,2	586	22,8	848	33		76		
21,7	386	17,8	579	26,7	846	39		89		
19,3	394	20,4	591	30,6	849	44		102		
7,1	433	61	650	91,5	902	127		305		
216	1080	5	1620	7,5	1944	9	10	20	25	
168	1075	6,4	1613	9,6	1848	11			32	
129	980	7,6	1471	11,4	1677	13			38	
112	986	8,8	1478	13,2	1792	16			44	
94	959	10,2	1438	15,3	1880	20			51	
72,1	923	12,8	1384	19,2	1803	25	Section du fil 4 x 3,2	64		
59,7	907	15,2	1361	22,8	1731	29		76		
50,5	899	17,8	1348	26,7	1768	35		89		
44,2	902	20,4	1353	30,6	1768	40		102		
38,4	883	23	1325	34,5	1805	47		115		
34,1	866	25,4	1299	38,1	1773	52	12,5	127		
31	862	27,8	1293	41,7	1767	57		139		
28,2	857	30,4	1286	45,6	1748	62		152		
15	915	61	1373	91,5	1815	121		305		
375	1875	5	2813	7,5	3375	9		25	25	
297	1901	6,4	2851	9,6	3267	11	32			
219	1664	7,6	2497	11,4	3066	14	38			
187	1646	8,8	2468	13,2	2992	16	44			
156	1591	10,2	2387	15,3	2694	19	51			
123	1574	12,8	2362	19,2	3198	26	Section du fil 5,6 x 4,1	64		
99	1505	15,2	2257	22,8	2871	29		76		
84	1495	17,8	2243	26,7	2940	35		89		
73	1489	20,4	2234	30,6	2847	39		102		
65	1495	23	2243	34,5	2925	45		115		
57,7	1466	25,4	2198	38,1	2770	48	203	127		
52,7	1465	27,8	2198	41,7	2846	54		139		
47,8	1453	30,4	2180	45,6	2868	60		152		
41	1460	35,6	2189	53,4	2747	67		178		
35,8	1453	40,6	2180	60,9	2864	80		203		
22,9	1397	61	2095	91,5	2725	119	305			

# RESSORT CHARGE FORTE COULEUR ROUGE

RECTANGULAR WIRE DIE SPRING RED COLOUR HEAVY LOAD SYSTEM-DRUCKFEDER, ROT



ISO 10243

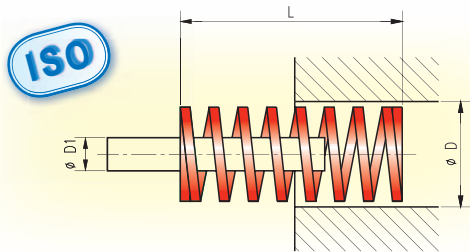

REF. 357 D=40 L=127 mm



357-40-127

K	A 20 %		B 30 %		C Approximatif		D1	D	L	REF. 357		
	N/mm	N	mm	N	mm	N					mm	mm
388	2949	7,6	4423	11,4	5044	13	16	32	38			
324	2851	8,8	4277	13,2	5184	16			44			
272	2774	10,2	4162	15,3	4896	18			51			
212	2714	12,8	4070	19,2	4876	23			64			
172	2614	15,2	3922	22,8	4644	27			76			
141	2510	17,8	3765	26,7	4653	33			89			
122	2489	20,4	3733	30,6	4758	39			102			
107	2461	23	3692	34,5	4601	43			115			
93	2362	25,4	3543	38,1	4371	47			127			
86	2391	27,8	3586	41,7	4386	51			139			
78	2371	30,4	3557	45,6	4290	55			152			
67,2	2392	35,6	3588	53,4	4637	69			178			
59,1	2399	40,6	3599	60,9	4787	81			203			
46,4	2357	50,8	3536	76,2	4594	99			254			
38	2318	61	3477	91,5	4522	119			305			
350	3570	10,2	5355	15,3	6300	18	20	40	51			
269	3443	12,8	5165	19,2	6725	25			64			
219	3329	15,2	4993	22,8	6570	30			76			
190	3382	17,8	5073	26,7	6840	36			89			
163	3325	20,4	4988	30,6	6683	41			102			
142	3266	23	4899	34,5	6674	47			115			
128	3251	25,4	4877	38,1	6784	53			127			
115	3197	27,8	4796	41,7	6440	56			139			
105	3192	30,4	4788	45,6	6510	62			152			
89	3168	35,6	4753	53,4	6230	70			178			
77	3126	40,6	4689	60,9	6391	83			203			
61	3099	50,8	4648	76,2	6161	101			254			
51	3111	61	4667	91,5	6477	127			305			
413	5286	12,8	7930	19,2	10738	26			25	50	64	
339	5153	15,2	7729	22,8	9831	29					76	
288	5126	17,8	7690	26,7	10080	35	89					
245	4998	20,4	7497	30,6	10045	41	102					
215	4945	23	7418	34,5	10105	47	115					
192	4877	25,4	7315	38,1	10560	55	127					
168	4670	27,8	7006	41,7	10248	61	139					
154	4682	30,4	7022	45,6	10164	66	152					
134	4770	35,6	7156	53,4	10050	75	178					
117	4750	40,6	7125	60,9	10179	87	203					
89	4521	50,8	6782	76,2	9612	108	254					
73	4453	61	6680	91,5	9709	133	305					
630	9576	15,2	14364	22,8	15120	24	38	63			76	
485	8633	17,8	12950	26,7	15520	32					89	
434	8854	20,4	13280	30,6	15624	36					102	
384	8832	23	13248	34,5	15360	40			115			
349	8865	25,4	13297	38,1	15356	44			127			
276	8390	30,4	12586	45,6	15456	56			152			
237	8437	35,6	12656	53,4	15405	65			178			
210	8526	40,6	12789	60,9	15540	74			203			
165	8382	50,8	12573	76,2	15510	94			254			
134	8174	61	12261	91,5	15410	115			305			

FORTE

## RESSORT CHARGE EXTRA FORTE COULEUR JAUNE

RECTANGULAR WIRE DIE SPRING YELLOW COLOUR EXTRA LOAD  
SYSTEM-DRUCKFEDER, GELB

ISO 10243



K	A 17 %		B 25 %		C Approximatif		D1 mm	D mm	L mm	REF. 358	
	N/mm	N	mm	N	mm	N					mm
36,8	156	4,3	230	6,3	331	9	5	10	25		
27,9	152	5,4	223	8	335	12			32		
23,7	153	6,5	225	9,5	332	14			38		
19,2	144	7,5	211	11	326	17			44		
16,5	143	8,7	210	12,8	314	19			51		
13,2	144	10,9	211	16	304	23	64				
10,9	141	12,9	207	19	327	30	76				
2,6	135	51,9	198	76,3	304	117	1,9 x 1,5		305		
58,5	249	4,3	366	6,3	527	9	6,3		12,5	25	
43,9	239	5,4	351	8	527	12				32	
36	233	6,5	342	9,5	504	14		38			
30,3	227	7,5	333	11	545	18		44			
26,2	227	8,7	334	12,8	524	20		51			
21,2	231	10,9	339	16	572	27		64			
17,1	221	12,9	325	19	547	32		76			
14,5	219	15,1	323	22,3	551	38		89			
12,5	216	17,3	319	25,5	513	41		102			
4,3	223	51,9	328	76,3	495	115		2,3 x 2,2		305	
118	502	4,3	738	6,3	1180	10	8	16	25		
89	484	5,4	712	8	1068	12			32		
72,1	466	6,5	685	9,5	1009	14			38		
60,9	456	7,5	670	11	1035	17			44		
52,3	453	8,7	667	12,8	994	19			51		
41,2	448	10,9	659	16	1030	25			64		
34,1	441	12,9	648	19	989	29			76		
29,5	446	15,1	656	22,3	1062	36			89		
25,6	444	17,3	653	25,5	973	38			102		
8,4	436	51,9	641	76,3	1008	120			3,2 x 2,7	305	
293	1245	4,3	1831	6,3	2051	7	10	20	25		
224	1219	5,4	1792	8	2240	10			32		
177	1143	6,5	1682	9,5	2124	12			38		
149	1115	7,5	1639	11	2086	14			44		
128	1110	8,7	1632	12,8	2048	16			51		
99	1077	10,9	1584	16	2178	22			64		
81,7	1056	12,9	1552	19	2043	25			76		
69,5	1052	15,1	1546	22,3	2155	31			89		
60,6	1051	17,3	1545	25,5	2182	36			102		
53	1036	19,6	1524	28,8	2226	42			115		
47,5	1026	21,6	1508	31,8	2043	43	127				
43	1016	23,6	1494	34,8	2064	48	139				
39	1008	25,8	1482	38	2028	52	152				
21,2	1099	51,9	1617	76,3	2226	105	4,1 x 3,7	305			
374	2037	5,4	2995	8	4118	11	12,5	25	32		
346	2235	6,5	3287	9,5	4498	13			38		
244	1825	7,5	2684	11	3904	16			44		
208	1799	8,7	2646	12,8	3735	18			51		
161	1752	10,9	2576	16	3703	23			64		
131	1690	12,9	2485	19	3401	26			76		
111	1672	15,1	2459	22,3	3426	31			89		
96,3	1670	17,3	2456	25,5	3467	36			102		
85,7	1675	19,6	2464	28,8	3514	41			115		
76,3	1647	21,6	2423	31,8	3586	47			127		
63,5	1641	25,8	2413	38	3429	54	152				
53,9	1631	30,3	2399	44,5	3396	63	178				
47	1622	34,5	2385	50,8	3384	72	203				
30,9	1602	51,9	2356	76,3	3492	113	5,6 x 4,6	305			

# RESSORT CHARGE EXTRA FORTE COULEUR JAUNE

RECTANGULAR WIRE DIE SPRING YELLOW COLOUR EXTRA LOAD  
SYSTEM-DRUCKFEDER, GELB



ISO 10243

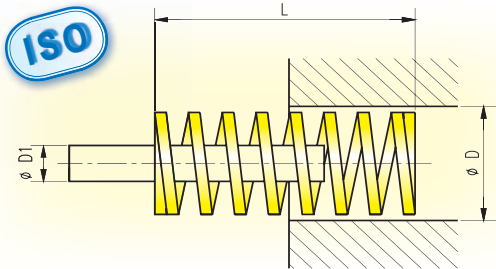

REF. 358 D=40 L=127 mm

358-40-127

K	A 17 %		B 25 %		C Approximatif		D1	D	L	REF. 358		
	N/mm	N	mm	N	mm	N					mm	mm
528	3412	6,5	5018	9,5	6338	12	16	32	38			
424	3175	7,5	4668	11	6366	15			44			
353	3061	8,7	4501	12,8	6001	17			51			
269	2929	10,9	4307	16	5922	22			64			
219	2823	12,9	4152	19	5463	25			76			
180	2728	15,1	4012	22,3	5950	33			89			
155	2688	17,3	3953	25,5	5580	36			102			
140	2737	19,6	4025	28,8	5880	42			115			
124	2677	21,6	3937	31,8	5704	46			127			
102	2636	25,8	3876	38	5712	56			152			
88,2	2669	30,3	3925	44,5	5645	64			178			
76	2623	34,5	3857	50,8	5396	71			203			
60,8	2625	43,2	3861	63,5	5472	90			254			
49	2541	51,9	3736	76,3	5047	103			305			
628	5445	8,7	8007	12,8	10676	17	20	40	51			
487	5299	10,9	7792	16	11201	23			64			
379	4897	12,9	7201	19	10233	27			76			
321	4857	15,1	7142	22,3	9951	31			89			
281	4873	17,3	7166	25,5	10116	36			102			
245	4790	19,6	7044	28,8	9800	40			115			
221	4771	21,6	7017	31,8	9724	44			127			
202	4773	23,6	7020	34,8	10504	52			139			
168	4341	25,8	6384	38	9408	56			152			
148	4478	30,3	6586	44,5	9028	61			178			
132	4555	34,5	6699	50,8	9636	73			203			
107	4620	43,2	6795	63,5	9951	93			254			
87,8	4552	51,9	6695	76,3	9307	106			305			
709	7714	10,9	11344	16	14889	21			25	50	64	
572	7390	12,9	10868	19	14300	25	76					
475	7187	15,1	10569	22,3	13300	28	89					
405	7023	17,3	10328	25,5	13365	33	102					
352	6882	19,6	10120	28,8	13376	38	115					
316	6822	21,6	10033	31,8	13588	43	127					
289	6829	23,6	10043	34,8	13583	47	139					
289	6829	23,6	10043	34,8	13583	47	152					
239	6176	25,8	9082	38	12667	53	178					
187	6453	34,5	9490	50,8	13277	71	203					
153	6607	43,2	9716	63,5	13923	91	254					
127	6585	51,9	9684	76,3	13462	106	305					
842	10879	12,9	15998	19	20208	24	38	63			76	
726	10984	15,1	16154	22,3	20328	28					89	
656	11375	17,3	16728	25,5	20336	31			102			
534	10440	19,6	15353	28,8	20292	38			115			
480	10363	21,6	15240	31,8	20160	42			127			
396	10233	25,8	15048	38	20196	51			152			
335	10137	30,3	14908	44,5	20100	60			178			
297	10249	34,5	15073	50,8	20196	68			203			
235	10147	43,2	14923	63,5	19975	85			254			
194	10059	51,9	14793	76,3	19982	103			305			
									13,3 x 11,8			

EXTRA FORTE

# RESSORT CHARGE HYPER FORTE COULEUR BRONZE

RECTANGULAR WIRE DIE SPRING BRONZE COLOUR HYPER LOAD SYSTEM-DRUCKFEDER, BRONZE

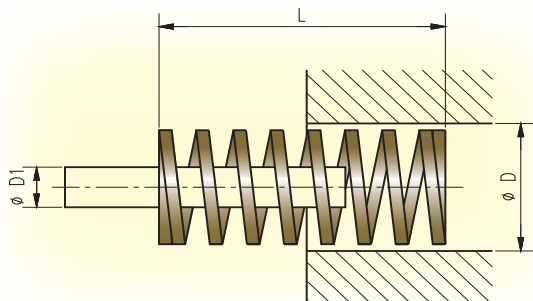

REF. 359 D=25 L=64 mm 359-25-64

K N/mm	A 10 %		C Comprimé à bloc approx.		D1 mm	D mm	L mm	REF. 359		
	N	mm	N	mm						
1158	5095	4,4	9264	8	12,5	25	44			
933	4758	5,1	9330	10			51			
644	4122	6,4	8372	13			64			
556	4226	7,6	8896	16			76			
462	4112	8,9	9240	20			89			
390	3978	10,2	8970	23			102			
360	4140	11,5	9360	26			115			
326	4140	12,7	9128	28			127			
255	3876	15,2	8670	34			152			
230	4094	17,8	8970	39			178			
202	4101	20,3	9090	45			203			
136	4148	30,5	8568	63			305			
1150	5865	5,1	12650	11	16	32	51			
887	5677	6,4	12418	14			64			
733	5570	7,6	12460	17			76			
612	5447	8,9	12853	21			89			
544	5544	10,2	12502	23			102			
494	5685	11,5	12359	25			115			
432	5490	12,7	12968	30			127			
356	5416	15,2	12471	35			152			
304	5409	17,8	12459	41			178			
265	5387	20,3	12472	47			203			
214	5436	25,4	12412	58			254			
177	5385	30,5	12359	70			305			
1228	7859	6,4	15964	13	20	40	64			
1017	7729	7,6	16272	16			76			
880	7832	8,9	17600	20			89			
762	7772	10,2	17526	23			102			
679	7809	11,5	17654	26			115			
622	7899	12,7	17416	28			127			
509	7737	15,2	18324	36			152			
429	7636	17,8	18447	43			178			
374	7592	20,3	18326	49			203			
296	7518	25,4	18352	62			254			
246	7503	30,5	18450	75			305			
1811	13764	7,6	25354	14			25	50	76	
1410	12549	8,9	26790	19	89					
1215	12393	10,2	26730	22	102					
1076	12374	11,5	26900	25	115					
968	12294	12,7	27104	28	127					
806	12251	15,2	27404	34	152					
698	12424	17,8	27920	40	178					
612	12424	20,3	27540	45	203					
472	11989	25,4	27376	58	254					
388	11834	30,5	27160	70	305					
					11,8 x 13,4					

# BOUCHON FILETE DE PRECONTRAINTE

SET SCREWS FOR COMPRESSION SPRING ADJUSTMENT  
 VERSCHLUSSSCHRAUBEN ALS VERSTELLBARER FEDERBODEN

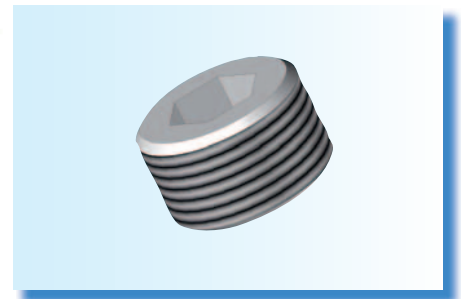

Exemple de montage

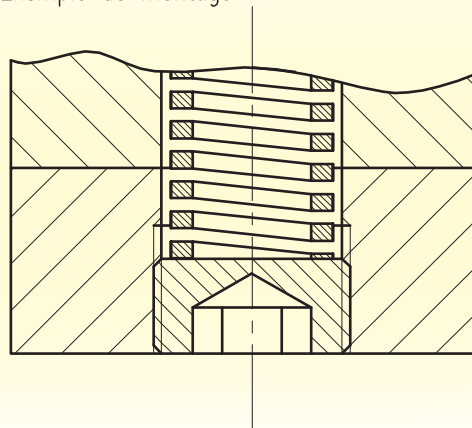
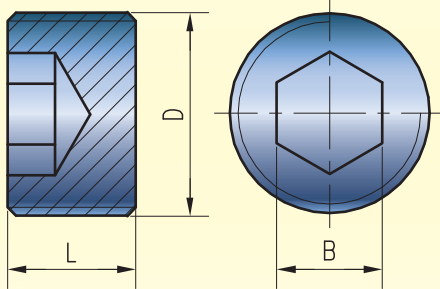

REF. 325 D=14



325-14

Pas	1,5	1,5	1,5	1,5	1,5	1,5	1,5	1,5
B	6	6	8	10	10	12	14	14
L	10	10	10	10	12	12	12	12
D	12	14	16	18	20	22	24	27
REF. 325								

## DISPOSITIF DE PRECONTRAINTE POUR RESSORT DE COMPRESSION

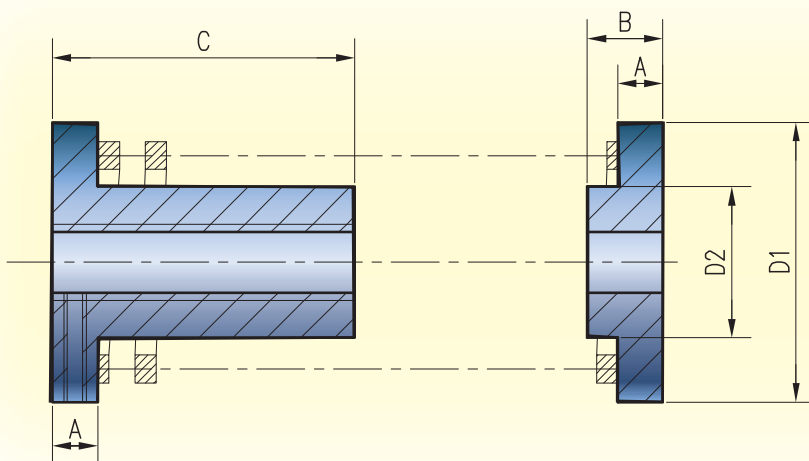
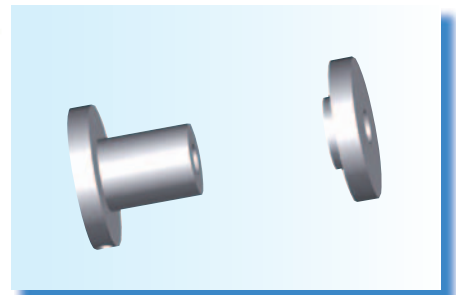
SPRING UNITS  
FEDEREINHEITEN

REF. 326 D=18,5



326-18,5

C	20	23	25	27
B	5	6,5	8	10
A	3	4	5	5
Filetage	M5	M6	M8	M10
D2	10	12,5	16	19
lamage du ressort	20	25	32	40
D1	18,5	24,5	31,5	37,5
REF. 326				

AXE DE GUIDAGE

GUIDE BOLT  
FÜHRUNGSBOLZEN

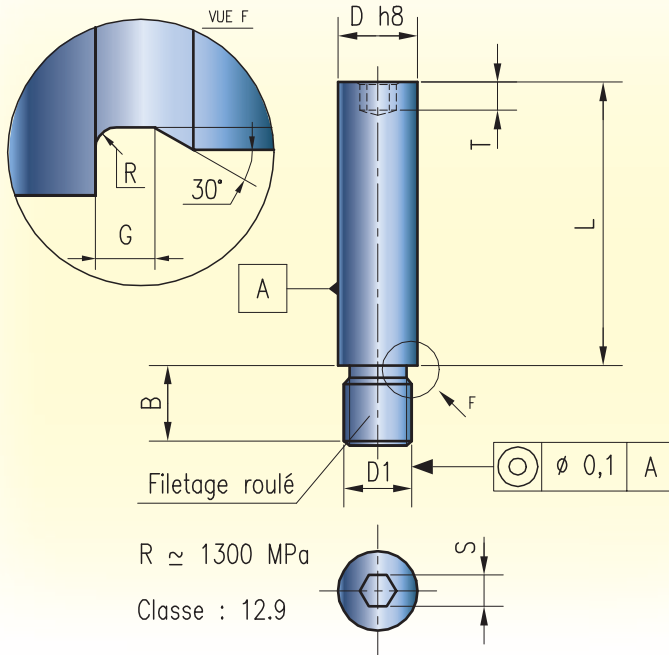
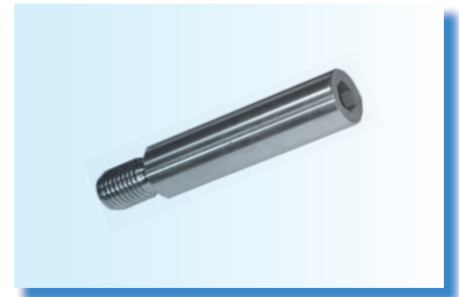

REF. 387 D=10 L=40 mm



387-10-40

Pas ISO	0,8	1	1,25	1,5	1,5	1,75	2	2,5
D1	M 5	M 6	M 8	M 10	M 10	M 12	M 16	M 20
B	8	10	12	16	16	20	25	32
S	3	4	5	6	6	8	10	14
G	1,2	1,5	1,9	2,2	2,2	2,6	3	3,7
R	0,4	0,5	0,6	0,8	0,8	0,9	1	1,2
T	2,5	3	4	5	5	6	8	11
L \ D	6	8	10	12	13	16	20	25
10								
12								
16								
20								
25								
32								
40								
50								
63								
80								
100								
120								
140								
160								
200								
250								



## RESSORT ELASTOMERE

URETHANE SPRING  
ELASTOMERFEDER

390 - 391

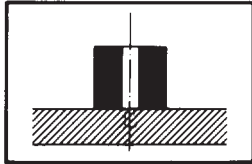

394

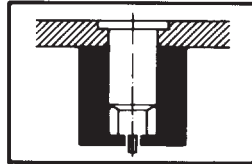

395

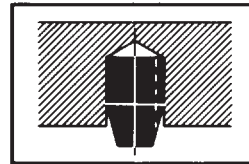

396 - 397

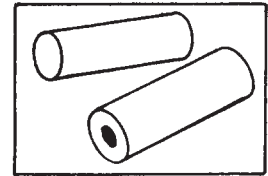

Ressorts en élastomère

Dévétisseurs

Décolleurs/Amortisseurs

Jets, Barres

### 2 qualités d'élastomère selon l'utilisation

- **Grande course**                      chloroprène (CR) 70 shore A                      Réf. 390
- **Grande puissance**                      polyuréthane (PUR) 90 shore A                      Réf. 391 - 394  
395 - 396  
397

### Important

#### Fréquence de Course

Le nombre de courses/minute en utilisation dynamique continue doit être pris en compte. Une augmentation de la cadence correspond à une diminution du pourcentage de compression. En restant en dessous de la valeur limite, la longévité augmente en raison du faible échauffement (Hystérisis).

Le module d'élasticité varie en fonction de la température dont la gamme se situe entre -20°C et +60°C.

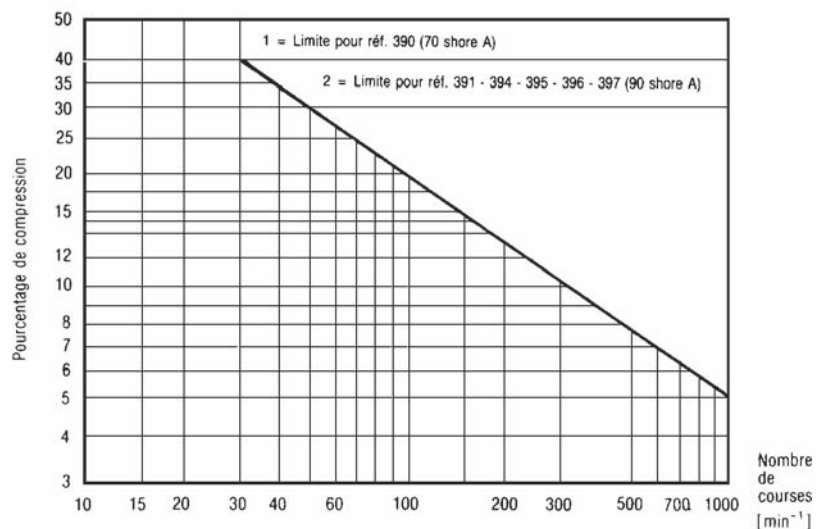



## RESSORT ELASTOMERE

URETHANE SPRING  
ELASTOMERFEDER

### Tolérances dimensionnelles

suivant norme M3 DIN 7715  
(températures +20°C).

### Tolérances de dureté

± 3 shore A (DIN 9835).

### Directives de montage

Les ressorts peuvent être utilisés séparément, en parallèle ou superposés. Leur comportement puissance/course est conforme aux lois d'élasticité des ressorts traditionnels. Les directives de montage ci-après doivent être respectées pour parvenir à une utilisation maximum.

### Mise en place

Les élastomères étant incompressibles, leur déformation sous charge se traduit par un gonflement. Le pourcentage de celui-ci est donc égal au pourcentage de compression.

Dimensions (mm)	Tolérances admissibles pour	
	D et D1 ± mm	H ± mm
Jusqu'à 6,3	0,25	0,4
Au-dessus 6,3 jusqu'à 10	0,3	0,5
Au-dessus 10 jusqu'à 16	0,4	0,6
Au-dessus 16 jusqu'à 25	0,5	0,8
Au-dessus 25 jusqu'à 40	0,6	1,0
Au-dessus 40 jusqu'à 53	0,8	1,3
Au-dessus 53 jusqu'à 100	1	1,6
Au-dessus 100 jusqu'à 120	1,3	2,0

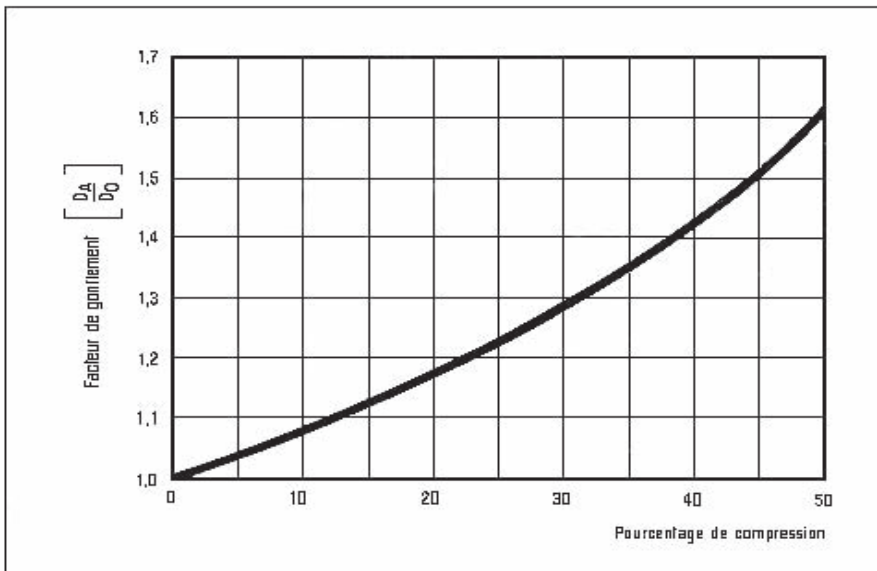
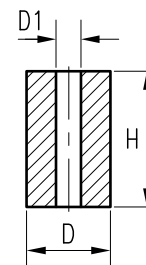

### Guidage

Pour guider, centrer, éviter les frottements et risque de flambage, il est préférable d'utiliser des axes. Ceux-ci sont indispensables dans un montage en colonne ou lorsque la hauteur du ressort est supérieure au diamètre.

### Montage en colonne

On obtient une plus grande course en superposant des ressorts. Ils seront guidés pour accroître leur longévité et séparés les uns des autres par des rondelles entretoises pour conserver leur autonomie de déformation. Sous une même puissance, les courses s'additionnent.

Courbe de gonflement

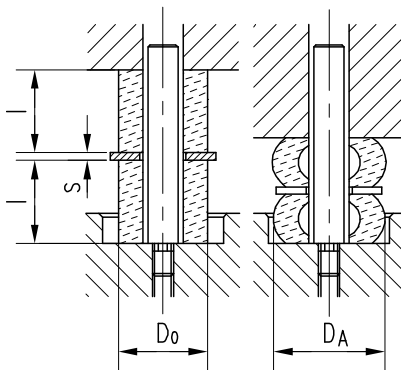

Guidage



Diagramme d'empilage

# RESSORT ELASTOMERE ( CHLOROPRÈNE NOIR)

URETHANE SPRING (CHLOROPRENE BLACK)  
ELASTOMERFEDER (SCHWARZ)

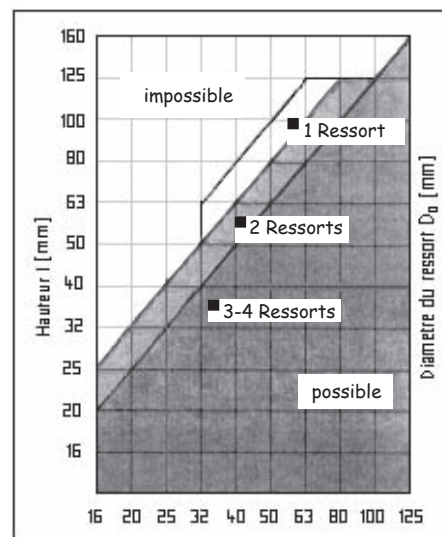
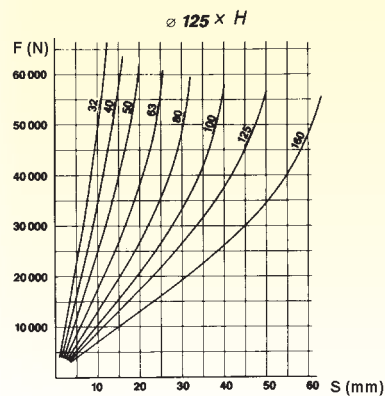
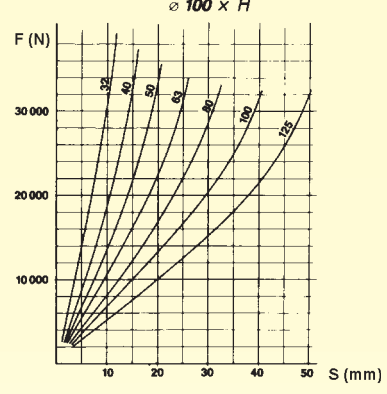
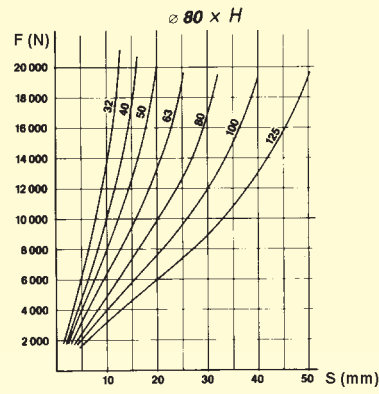
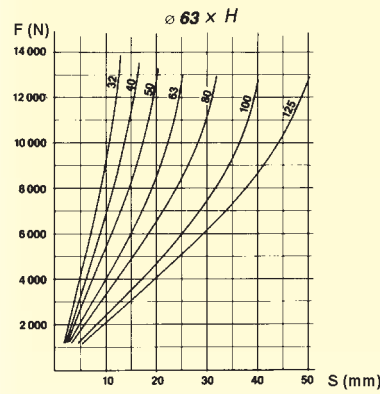
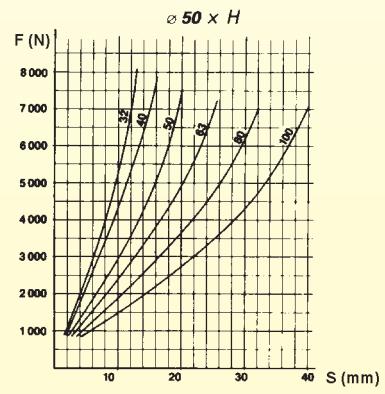
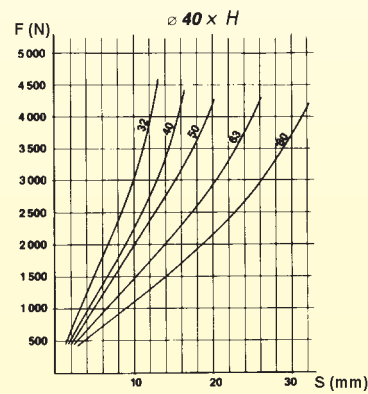
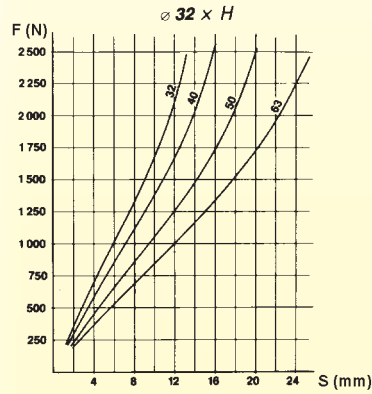
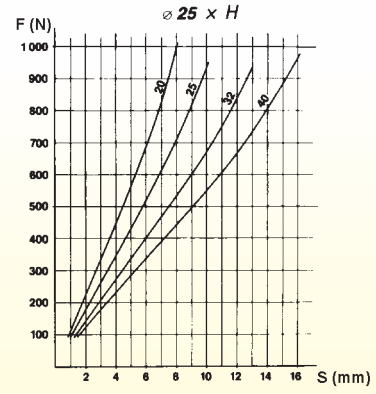
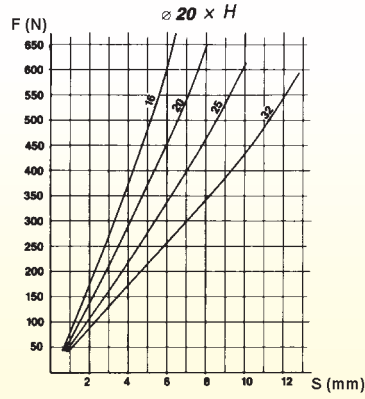
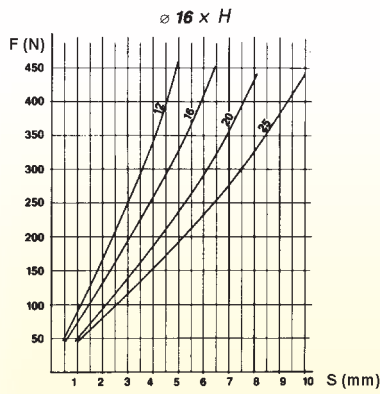
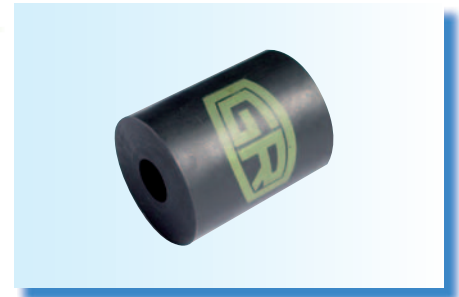

S : course  
1 N = 0,102 Kgf

## RESSORT ELASTOMERE ( CHLOROPRÈNE NOIR)

URETHANE SPRING (CHLOROPRENE BLACK)  
ELASTOMERFEDER (SCHWARZ)

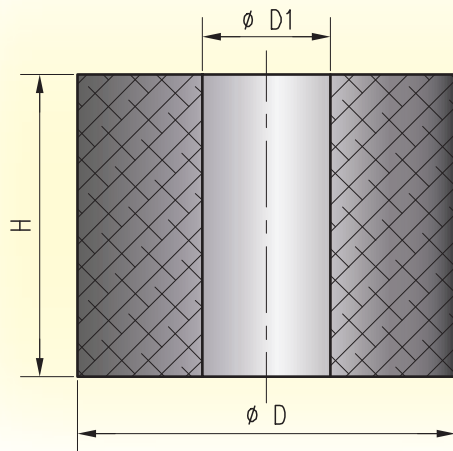
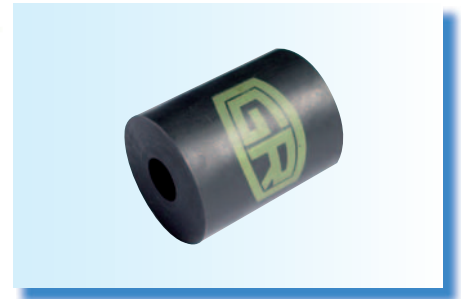

Mat : Chloroprène 70 shore (couleur noire)



REF. 390 D=40 L=32 mm



390-40-32

D1	H \ D	12	16	20	25	32	40	50	63	80	100	125
6,5	16											
8,5	20											
10,5	25											
13,5	32											
13,5	40											
17	50											
17	63											
21	80											
21	100											
27	125											

# RESSORT ELASTOMERE ( POLYURÉTHANE ROUGE )

URETHANE SPRING (PUR RED)  
ELASTOMERFEDER (ROT)

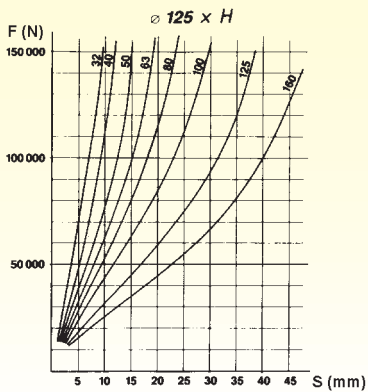
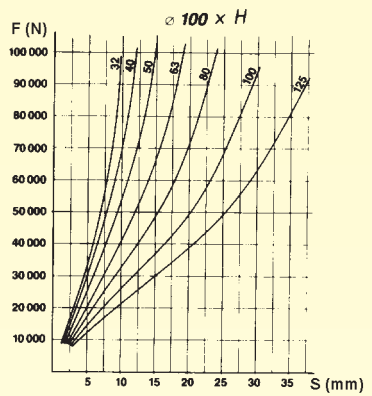
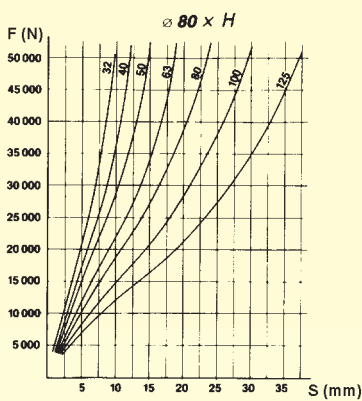
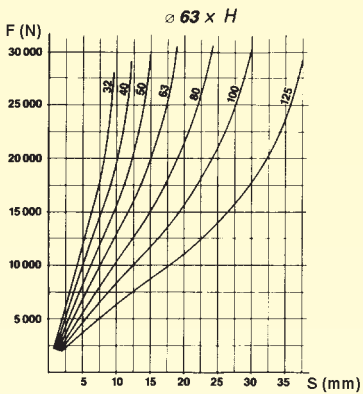
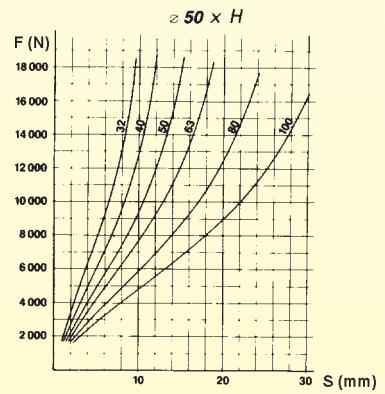
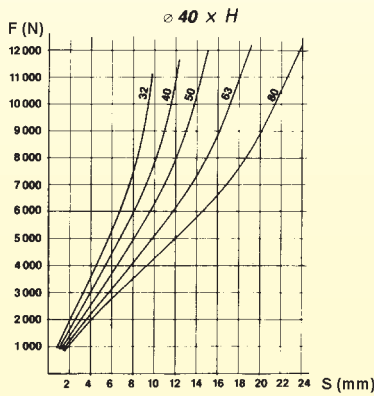
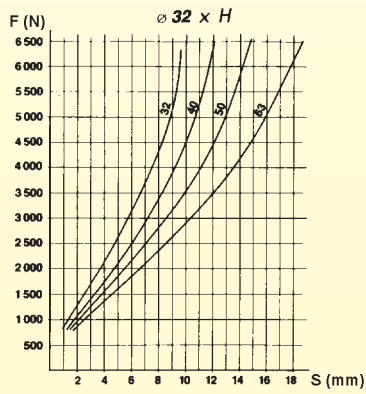
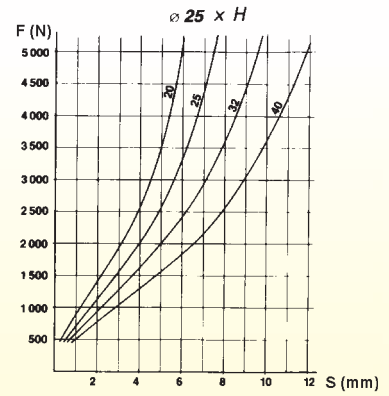
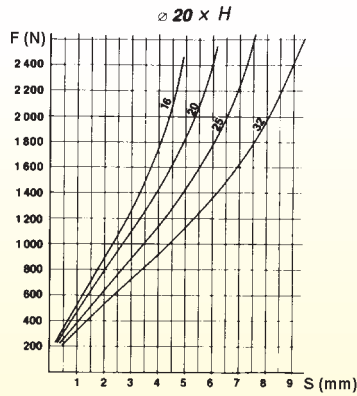
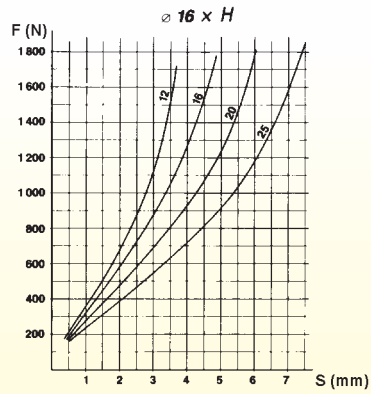

S : course  
1 N = 0,102 Kgf

## RESSORT ELASTOMERE ( POLYURÉTHANE ROUGE)

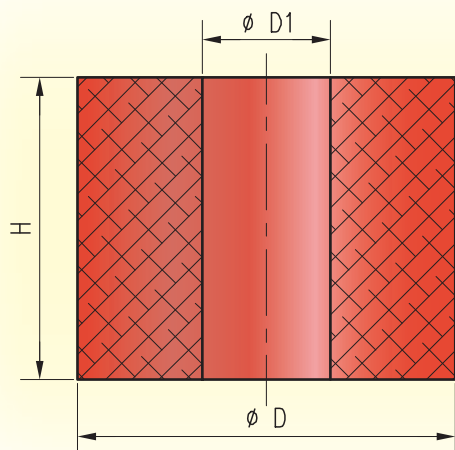
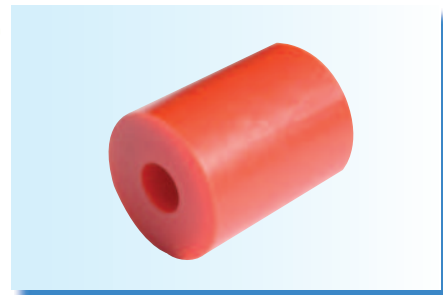
URETHANE SPRING (PUR RED)  
ELASTOMERFEDER (ROT)

Mat : Polyuréthane 90 shore (couleur rouge)



REF. 391 D=40 L=32 mm



391-40-32

D1	H \ D	12	16	20	25	32	40	50	63	80	100	125
6,5	16											
8,5	20											
10,5	25											
13,5	32											
13,5	40											
17	50											
17	63											
21	80											
21	100											
27	125											

## DEVETISSEUR DE POINÇON ( POLYURÉTHANE )

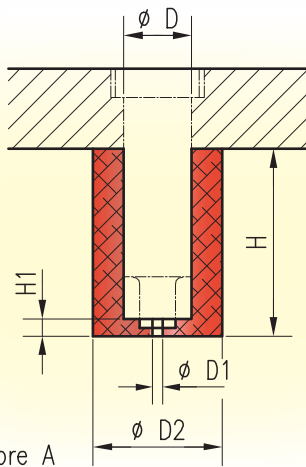
URETHANE STRIPPER ( PUR )  
ABSTREIFER

Se montent par emmanchement serré sur tous poinçons cylindriques de forme, ronde, carrée, ovale, triangulaire, etc...

**Montage :**

La longueur du dévêtitseur doit être supérieure de 1 à 2 mm à celle de dépassement du poinçon.

Ils peuvent être coupés à longueur suivant besoin. Prévoir l'espace de gonflement.



REF. 394 D=10 H=55 mm



394-10-55

D2	H1	D1	Force (N) sous course de			D	H	REF. 394
			3 mm	6 mm	9 mm			
17	5	1,6	600	1500	--	4	45	
19	5	1,6	650	1200	1800	6	55	
21	5	3	700	1300	2100	8	55	
23	5	3	900	1600	2400	10	55	
26	5	3	1100	1900	3000	13	55	
30	5	3	1400	2300	3700	16	55	
38	5	3	2100	3600	5500	20	55	
50	5	3	3700	6500	10200	25	55	

## DECOLLEUR ( POLYURÉTHANE )

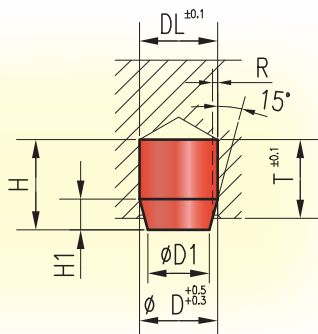
EJECTOR / CUSHION ( PUR )  
AUSHEBER / PUFFER

Utilisés sur les outils et moules pour, éjecter, amortir et réduire le niveau sonore des impacts.

**Montage :**

Un trou borgne suffit à recevoir le décolleur doté d'un évent pour faciliter l'évacuation de l'air lors de la mise en place.



REF. 395 D=24 mm



395-24

H	H1	D1	R	DL	T	F (N) maxi	D	REF. 395
9,5	4,5	3,6	--	6	8	100	6	
15,5	7,5	6	1	10	13	450	10	
25	12	9,5	1,5	16	21	1500	16	
25	10	18	2	24	21	3000	24	
35	19	20	2,5	30	30	3000	30	
32	14	24	3	32	26	12000	32	
40	16	30	3	39,5	34	25000	39,5	

396



## JET CREUX ( POLYURÉTHANE )

HOLLOW ROD ( PUR )  
FEDERSTAB /-STANGE

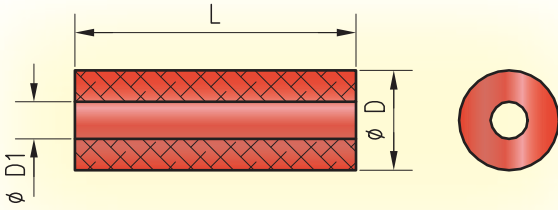

90 Shore A

Usinables, ces jets permettent la réalisation de pièces prototypes ou de pré-série dont les dimensions ou formes ne correspondent pas aux dimensions de notre standard.



REF. 396 D=25 L=300 mm



396-25-300

D1	D	L	REF. 396
6,5	16	300	
8,5	20	300	
10,5	25	300	
13,5	32	300	
13,5	40	300	
17	50	400	
17	63	400	
21	80	400	
21	100	300	
27	125	300	

397



## JET PLEIN ( POLYURÉTHANE )

SOLID ROD ( PUR )  
FEDERSTAB /-STANGE

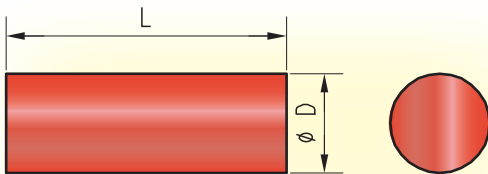

90 Shore A

Usinables, ces jets permettent la réalisation de pièces prototypes ou de pré-série dont les dimensions ou formes ne correspondent pas aux dimensions de notre standard.



REF. 397 D=25 L=300 mm



397-25-300

D	L	REF. 397
16	300	
20	300	
25	300	
32	300	
40	300	
50	400	
63	400	
80	400	
100	300	
125	300	

**389**

## RONDELLE ENTRETOISE (LAITON)

SPACER (BRASS)  
DISTANZSCHEIBE (MESSING)

DIN 9835 FORME A

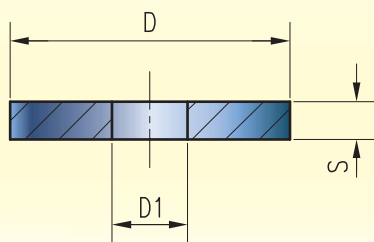

REF. 389 D=20



389-20

D1	6,5	8,5	10,5	13,5	13,5	16,5	16,5
S	4	4	5	5	5	6	6
D	20	25	30	40	50	60	80
REF. 389							

# RONDELLE RESSORT

DISC SPRING  
TELLERFEDER

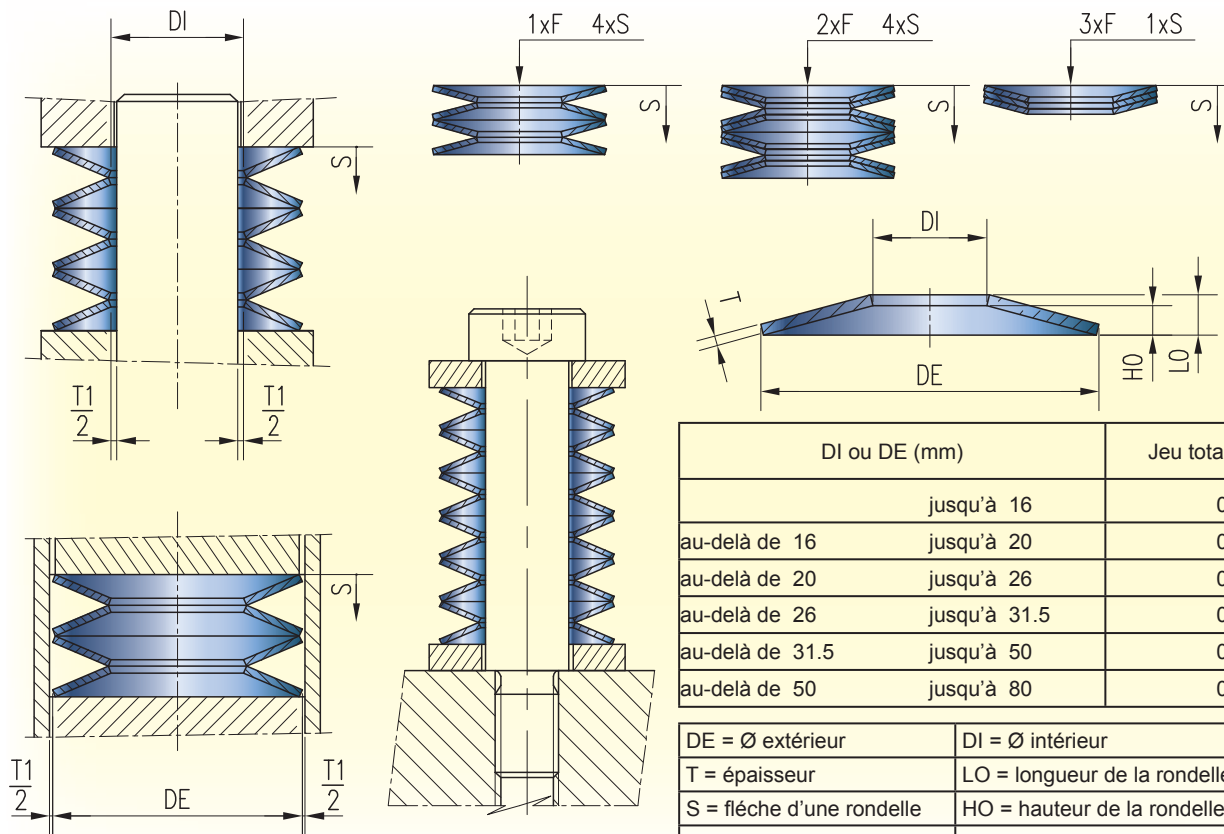
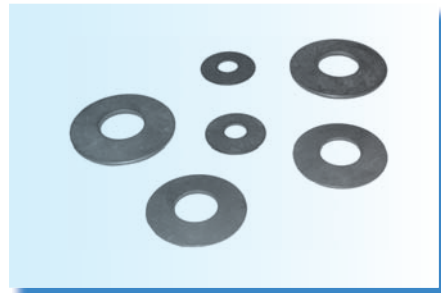

DI ou DE (mm)		Jeu total T1 (mm)
jusqu'à 16		0,2
au-delà de 16	jusqu'à 20	0,3
au-delà de 20	jusqu'à 26	0,4
au-delà de 26	jusqu'à 31.5	0,5
au-delà de 31.5	jusqu'à 50	0,6
au-delà de 50	jusqu'à 80	0,8

DE = Ø extérieur	DI = Ø intérieur
T = épaisseur	LO = longueur de la rondelle à l'état libre
S = flèche d'une rondelle	HO = hauteur de la rondelle à l'état libre
F = effort de la rondelle	



REF. 385 DE=8 Modèle=3



385-8-3

DI	T	LO	HO	S=0.25H0		S=0.5H0		S=0.75H0		DE	Modèle	REF. 385
				S (mm)	F (N)	S (mm)	F (N)	S (mm)	F (N)			
3,2	0,3	0,55	0,25	0,062	45,6	0,125	79,1	0,187	104,3	8	1	
	0,4	0,6	0,2	0,05	69,2	0,1	130,1	0,15	185,5		2	
4,2	0,3	0,55	0,25	0,062	51,6	0,125	89,3	0,187	117,9		3	
	0,4	0,6	0,2	0,05	78,2	0,1	147	0,15	209,5		4	
3,2	0,3	0,65	0,35	0,087	51,1	0,175	81,6	0,262	98,3	10	1	
	0,4	0,7	0,3	0,075	75,1	0,15	132,9	0,225	179,1		2	
	0,5	0,85	0,35	0,087	165,3	0,175	296,1	0,262	404		3	
4,2	0,4	0,7	0,3	0,075	79,3	0,15	140,3	0,225	189,1		4	
	0,5	0,75	0,25	0,062	109,8	0,125	206,3	0,187	294		5	
5,2	0,4	0,7	0,3	0,075	87,8	0,15	155,3	0,225	209,3		6	
	0,5	0,75	0,25	0,062	121,5	0,125	228,3	0,187	325,3	7		
4,2	0,4	0,8	0,4	0,1	85,1	0,2	141,4	0,3	178,3	12	1	
	0,5	0,9	0,4	0,1	142,6	0,2	249	0,3	331,4		2	
5,2	0,5	0,9	0,4	0,1	150,4	0,2	262,7	0,3	349,6		3	
	0,6	0,95	0,35	0,087	195,9	0,175	361,2	0,262	506,1		4	
6,2	0,5	0,85	0,35	0,087	133,5	0,175	239,2	0,262	326,4		5	
	0,6	0,95	0,35	0,087	213,6	0,175	393,8	0,262	551,7		6	
6,2	0,5	0,85	0,35	0,087	120	0,175	215,1	0,262	293,4	12,5	1	
	0,7	1	0,3	0,075	239,4	0,15	456,8	0,225	659,5		2	

## RONDELLE RESSORT

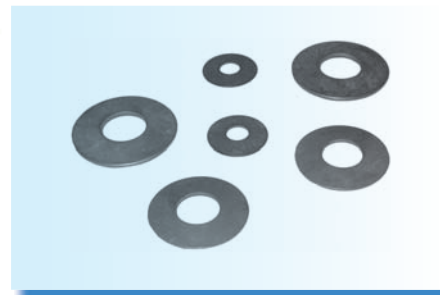
DISC SPRING  
TELLERFEDER

DI	T	L0	H0	S=0.25H0		S=0.5H0		S=0.75H0		DE	Modèle	REF. 385
				S (mm)	F (N)	S (mm)	F (N)	S (mm)	F (N)			
7,2	0,5	0,9	0,4	0,1	120,1	0,2	209,8	0,3	279,2	14	1	
	0,8	1,1	0,3	0,075	283,8	0,15	547,2	0,225	796,8		2	
5,2	0,4	0,95	0,55	0,137	101,2	0,275	154,4	0,412	175,5	15	1	
	0,5	1	0,5	0,125	132,8	0,25	220,6	0,375	278,2		2	
	0,6	1,05	0,45	0,112	170,8	0,225	302,1	0,337	407,2		3	
	0,7	1,25	0,55	0,137	340,2	0,275	596,4	0,412	796,5		4	
6,2	0,5	1	0,5	0,125	138,1	0,25	229,4	0,375	289,4	15	5	
	0,6	1,05	0,45	0,112	177,6	0,225	314,2	0,337	423,5		6	
	0,7	1,1	0,4	0,1	222,4	0,2	411,1	0,3	577,5		7	
8,2	0,7	1,1	0,4	0,1	256,3	0,2	473,9	0,3	665,68	15	8	
	0,8	1,2	0,4	0,1	366,8	0,2	689,3	0,3	982,3		9	
8,2	0,6	1,05	0,45	0,112	172	0,225	304,3	0,337	410	16	1	
	0,9	1,25	0,35	0,087	362,5	0,175	697	0,262	1013		2	
6,2	0,4	1	0,6	0,15	84,6	0,3	126,1	0,45	138,6	18	1	
	0,5	1,1	0,6	0,15	129,9	0,3	205,7	0,45	245,4		2	
	0,6	1,2	0,6	0,15	191,1	0,3	317,3	0,45	400,3		3	
	0,7	1,4	0,7	0,175	354,1	0,35	588	0,525	741,7		4	
	0,8	1,5	0,7	0,175	479,5	0,35	821,6	0,525	1072		5	
8,2	0,7	1,25	0,55	0,137	254,6	0,275	446,2	0,412	596	18	6	
	0,8	1,3	0,5	0,125	308,9	0,25	563,8	0,375	782,6		7	
9,2	0,7	1,2	0,5	0,125	233,4	0,25	416,6	0,375	566,4	18	8	
	1	1,4	0,4	0,1	450,6	0,2	865	0,3	1254		9	
8,2	0,6	1,3	0,7	0,175	214,4	0,35	342,1	0,525	412	20	1	
	0,7	1,35	0,65	0,162	261,5	0,325	442	0,487	568,5		2	
	0,8	1,4	0,6	0,15	315	0,3	557,3	0,45	751		3	
	0,9	1,5	0,6	0,15	423,2	0,3	764,5	0,45	1051		4	
10,2	0,8	1,35	0,55	0,137	304,3	0,275	546,8	0,412	748,2	20	5	
	0,9	1,45	0,55	0,137	411,7	0,275	754	0,412	1050		6	
	1	1,55	0,55	0,137	543,6	0,275	1010	0,412	1425		7	
	1,1	1,55	0,45	0,112	548,2	0,225	1050	0,337	1521		8	
11,2	0,8	1,45	0,65	0,162	306,3	0,325	533,4	0,487	707,4	22,5	1	
	1,25	1,75	0,5	0,125	693,1	0,25	1330	0,375	1929		2	
8,2	0,7	1,5	0,8	0,2	279,4	0,4	448,4	0,6	543,6	23	1	
	0,8	1,55	0,75	0,187	332	0,375	560	0,562	718,5		2	
	0,9	1,7	0,8	0,2	485,7	0,4	829,2	0,6	1078		3	
10,2	0,9	1,65	0,75	0,187	463,1	0,375	801,9	0,562	1058	23	4	
	1	1,7	0,7	0,175	538,2	0,35	964,2	0,525	1315		5	
12,2	1,25	1,85	0,6	0,15	863,4	0,3	1630	0,45	2331	25	6	
12,2	0,9	1,6	0,7	0,175	366,8	0,35	644,3	0,525	862,3		1	
	1,5	2,05	0,55	0,137	1040	0,275	2007	0,412	2926	2		
10,2	0,8	1,75	0,95	0,237	347,9	0,475	552,5	0,712	661,5	28	1	
	1	2	1	0,25	615,2	0,5	1022	0,75	1289		2	
	1,25	2,25	1	0,25	1030	0,5	1799	0,75	2394		3	
12,2	1	1,95	0,95	0,237	589,9	0,475	991,7	0,712	1268	28	4	
	1,25	2,1	0,85	0,212	843,8	0,425	1519	0,637	2083		5	
	1,5	2,25	0,75	0,187	1149	0,375	2159	0,562	3077		6	
14,2	1	1,8	0,8	0,2	476,4	0,4	832	0,6	1107	28	7	
	1,25	2,1	0,85	0,212	907,4	0,425	1634	0,637	2240		8	
	1,5	2,15	0,65	0,162	1033	0,325	1970	0,487	2841		9	

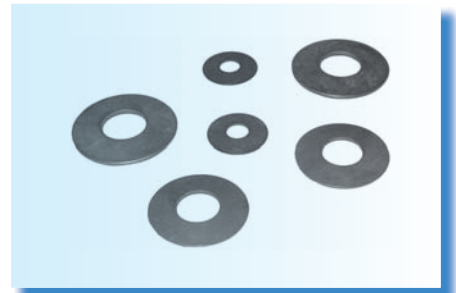

## RONDELLE RESSORT

DISC SPRING  
TELLERFEDER

DI	T	LO	HO	S=0.25H0		S=0.5H0		S=0.75H0		DE	Modèle	REF. 385
				S (mm)	F (N)	S (mm)	F (N)	S (mm)	F (N)			
16,3	1,25	2,15	0,9	0,225	790,5	0,45	1409	0,675	1913	31,5	1	
	1,75	2,45	0,7	0,175	1391	0,35	2669	0,525	3871		2	
12,3	1	2,2	1,2	0,3	587,2	0,6	930	0,9	1110	34	1	
	1,25	2,45	1,2	0,3	946,4	0,6	1587	0,9	2024		2	
	1,5	2,7	1,2	0,3	1447	0,6	2527	0,9	3363		3	
14,3	1,25	2,4	1,15	0,287	912,8	0,575	1546	0,862	1993	34	4	
	1,5	2,55	1,05	0,262	1224	0,525	2192	0,787	2990		5	
16,3	1,5	2,55	1,05	0,262	1291	0,525	2313	0,787	3155	35,5	6	
	2	2,85	0,85	0,212	2097	0,425	4003	0,637	5783		7	
18,3	1,25	2,25	1	0,25	730,9	0,5	1277	0,75	1699	35,5	1	
	2	2,8	0,8	0,2	1864	0,4	3576	0,6	5187		2	
14,3	1,25	2,65	1,4	0,35	904,4	0,7	1459	1,05	1780	40	1	
	1,5	2,8	1,3	0,325	1188	0,65	2040	0,975	2668		2	
	2	3,05	1,05	0,262	1800	0,525	3363	0,787	4769		3	
16,3	1,5	2,8	1,3	0,325	1224	0,65	2102	0,975	2749	40	4	
	2	3,1	1,1	0,275	1972	0,55	3663	0,825	5169		5	
18,3	2	3,15	1,15	0,287	2182	0,575	4030	0,862	5656	40	6	
	1,5	2,65	1,15	0,287	1109	0,575	1953	0,862	2621		7	
20,4	2	3,1	1,1	0,275	2175	0,55	4041	0,825	5701	40	8	
	2,25	3,15	0,9	0,225	2336	0,45	4481	0,675	6500		9	
	2,5	3,45	0,95	0,237	3351	0,475	6453	0,712	9390		10	
	1,75	3,05	1,3	0,325	1524	0,65	2701	0,975	3646		45	1
2,5	3,5	1	0,25	2773	0,5	5320	0,75	7716	2			
18,4	1,5	3,15	1,65	0,412	1166	0,825	1890	1,237	2319	50	1	
	2	3,65	1,65	0,412	2229	0,825	3868	1,237	5114		2	
20,4	2	3,5	1,5	0,375	1966	0,75	3478	1,125	4687	50	3	
	2,5	3,85	1,35	0,337	3008	0,675	5601	1,012	7919		4	
22,4	2	3,6	1,6	0,4	2247	0,8	3924	1,2	5222	50	5	
	2,5	3,9	1,4	0,35	3261	0,7	6044	1,05	8510		6	
25,4	2	3,4	1,4	0,35	1949	0,7	3491	1,05	4762	50	7	
	2,5	3,9	1,4	0,35	3473	0,7	6437	1,05	9063		8	
	3	4,1	1,1	0,275	4255	0,55	8214	0,825	11976		9	
28,5	2	3,6	1,6	0,4	1910	0,8	3335	1,2	4438	56	1	
	3	4,3	1,3	0,325	4142	0,65	7895	0,975	11388		2	
20,5	2	4,2	2,2	0,55	2528	1,1	4097	1,65	5026	60	1	
	2,5	4,7	2,2	0,55	4151	1,1	7102	1,65	9255		2	
25,5	2,5	4,4	1,9	0,475	3447	0,95	6081	1,425	8175	60	3	
	3	4,65	1,65	0,412	4495	0,825	8352	1,237	11784		4	
30,5	3	4,7	1,7	0,425	5083	0,85	9407	1,275	13226	60	5	
	3,5	5	1,5	0,375	6591	0,75	12574	1,125	18153		6	
31	2,5	4,25	1,75	0,437	2942	0,875	5270	1,312	7189	63	1	
	3,5	4,9	1,4	0,35	5399	0,7	10359	1,05	15025		2	
25,5	2	4,5	2,5	0,625	2408	1,25	3771	1,875	4437	70	1	
30,5	2,5	4,9	2,4	0,6	3755	1,2	6297	1,8	8031		2	
	3	5,1	2,1	0,525	4676	1,05	8376	1,575	11426		3	
35,5	3	5,1	2,1	0,525	5028	1,05	9007	1,575	12287	70	4	
	4	5,8	1,8	0,45	8757	0,9	16634	1,35	23923		5	
40,5	4	5,7	1,7	0,425	9025	0,85	17230	1,275	24889	70	6	
	5	6,4	1,4	0,35	13646	0,7	26719	1,05	39410		7	
36	2,5	4,5	2	0,5	2894	1	5054	1,5	6725	71	1	
	4	5,6	1,6	0,4	7379	0,8	14157	1,2	20535		2	

# GOUPILLE CYLINDRIQUE

DOWEL PIN  
ZYLINDERSTIFT

NF EN 28734, ISO 8734

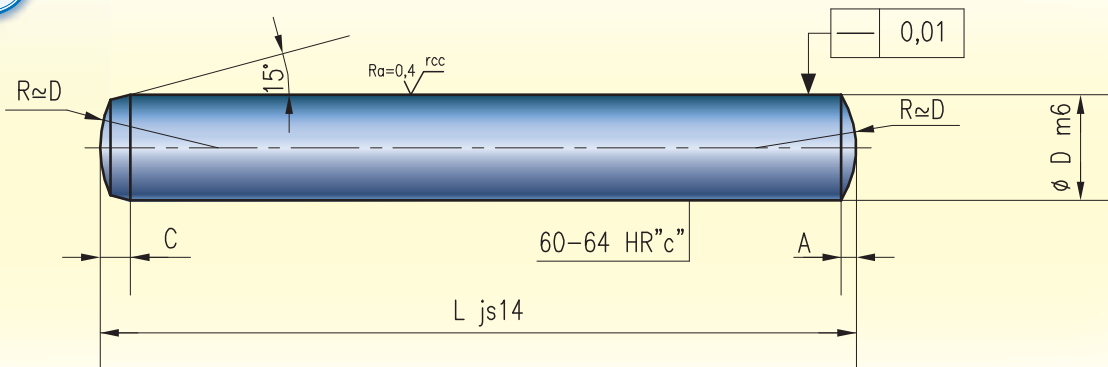
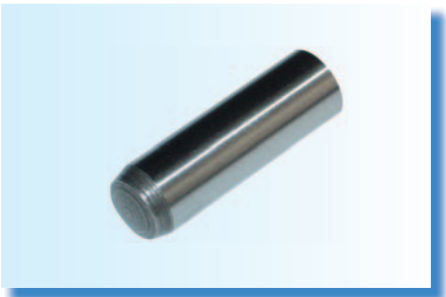

REF. 501 (ou 3111) D=8 L=60 mm



501-8-60 ( Fabrications spéciales sur demande )

A	0,12	0,2	0,25	0,3	0,4	0,5	0,63	0,8	1	1	1	1,2	1,2	1,6	2	2	2	2,5
C	0,5	0,6	0,8	1	1,2	1,4	1,7	2,1	2,1	2,6	2,7	3	3,2	3,8	4	4,6	5	6
L \ D	1	1,5	2	2,5	3	4	5	6	7	8	9	10	11	12	14	16	18	20
4																		
5																		
6																		
8																		
10																		
12																		
14																		
16																		
18																		
20																		
24																		
28																		
30																		
32																		
36																		
40																		
45																		
50																		
55																		
60																		
65																		
70																		
75																		
80																		
85																		
90																		
100																		
110																		
120																		
140																		
150																		
160																		
180																		



GOUPILLE CYLINDRIQUE NITROCARB®

NITROCARB® DOWEL PIN  
NITROCARB® ZYLINDERSTIFT

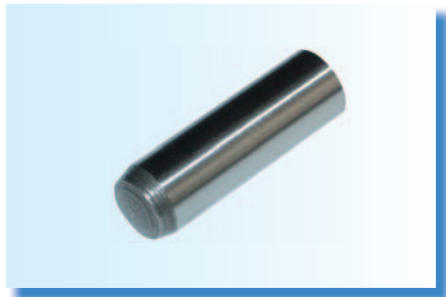

NF EN 28734, ISO 8734

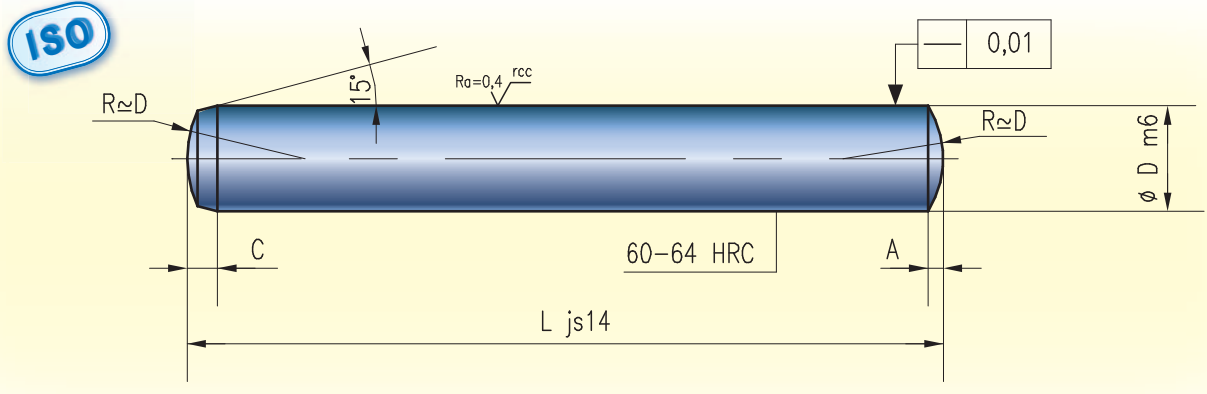

REF. 3112 D=5 L=20 mm      3112-5-20 ( Fabrications spéciales sur demande )

A	0,12	0,2	0,25	0,3	0,4	0,5	0,63	0,8	1	1,2	1,6	2	2,5
C	0,5	0,6	0,8	1	1,2	1,4	1,7	2,1	2,6	3	3,8	4,6	6
L \ D	1	1,5	2	2,5	3	4	5	6	8	10	12	16	20
5													
8													
10													
12													
14													
16													
18													
20													
24													
28													
30													
32													
36													
40													
45													
50													
55													
60													
65													
70													
75													
80													
85													
90													
100													
110													
120													
140													
150													
160													
180													

502



GOUPILLE CYLINDRIQUE EN ACIER INOXYDABLE

DOWEL PIN  
ZYLINDERSTIFT

DIN 7 / AISI 303

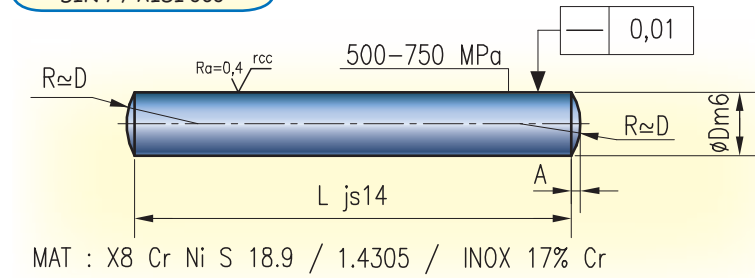

REF. 502 D=8 L=50 mm 502-8-50

A	0,15	0,23	0,3	0,45	0,6	0,75	0,9	1,2	1,5
L \ D	1	1,5	2	3	4	5	6	8	10
4									
5									
6									
8									
10									
12									
16									
20									
24									
30									
40									
50									
60									

503



GOUPILLE CYLINDRIQUE EN ACIER INOXYDABLE

DOWEL PIN  
ZYLINDERSTIFT

DIN 7 / A4 / AISI 316

Haute résistance à la corrosion

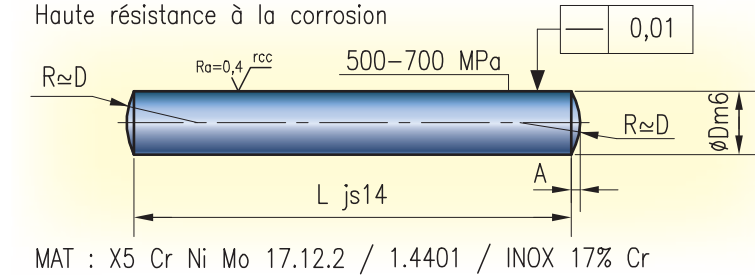

REF. 503 D=8 L=50 mm 503-8-50

A	0,23	0,3	0,45	0,6	0,75	0,9	1,2	1,5
L \ D	1,5	2	3	4	5	6	8	10
4								
5								
6								
8								
10								
12								
16								
20								
24								
30								
40								
50								
60								

GOUPILLE CYLINDRIQUE A TROU TARAUDE EN ACIER INOXYDABLE RINOX GR®

EXTRACTABLE DOWEL PIN STAINLESS STEEL RINOX GR®  
ZYLINDERSTIFT MIT INNENGEWINDE RINOX GR®



DIMENSION NFEN 28735, ISO 8735

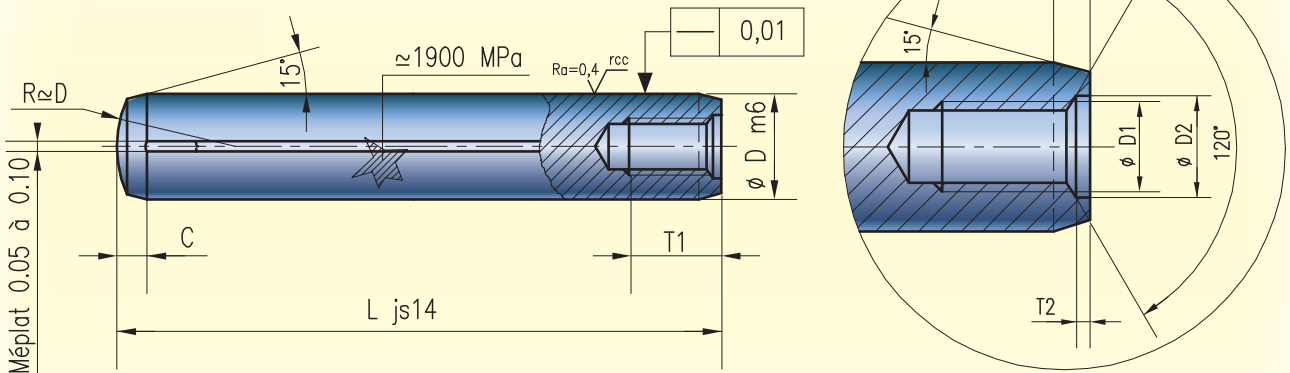

Mat : INOX 17 % Cr (Sur demande possibilité de nitruration.)  
52-55 HRC  
T : 500°C



REF. 523 D=8 L=60 mm



523-8-60 ( Fabrications spéciales sur demande )

B max	0,8	1	1,2	1,6	2
C	2,1	2,6	3	3,8	4,6
D1	M 4	M 5	M 6	M 6	M 8
D2	4,3	5,3	6,4	6,4	8,4
T1	6	8	10	12	16
T2	1	1,2	1,2	1,2	1,5
<b>L \ D</b>	<b>6</b>	<b>8</b>	<b>10</b>	<b>12</b>	<b>16</b>
12					
16					
20					
24					
30					
32					
36					
40					
50					
60					
80					
100					
120					

# GOUPILLE CYLINDRIQUE A TROU TARAUDE

EXTRACTABLE DOWEL PIN  
ZYLINDERSTIFT MIT INNENGEWINDE

NF EN 28735, ISO 8735

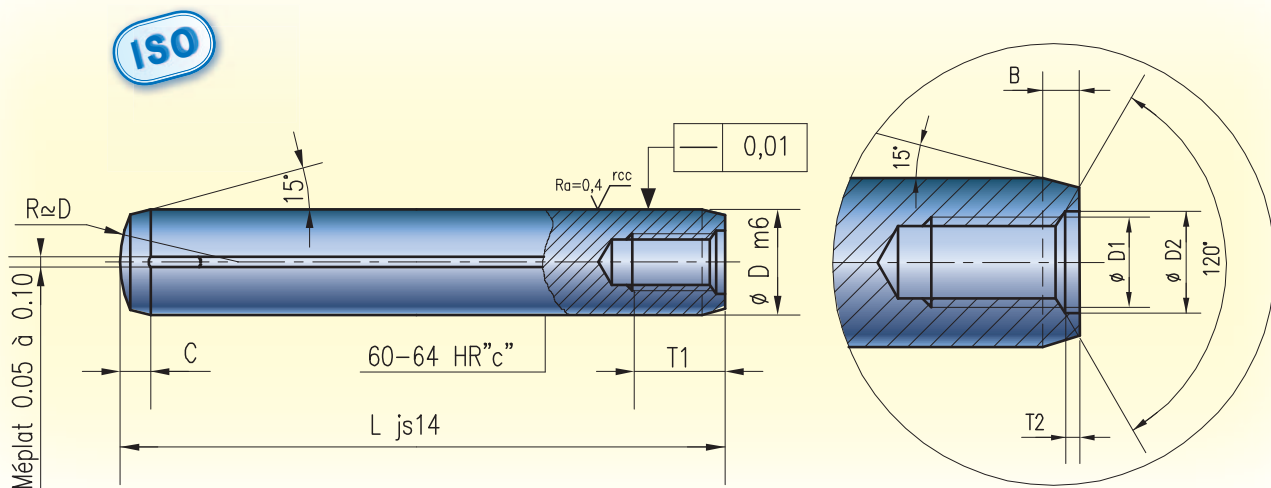
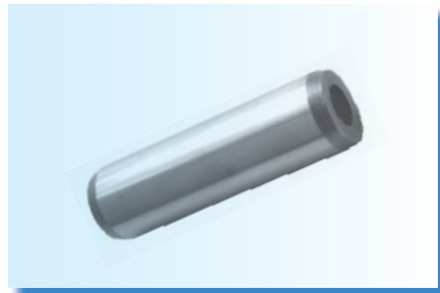

REF. 521 (ou 3121) D=8 L=60 mm



521-8-60 ( Fabrications spéciales sur demande )

B max	0,8	1	1,2	1,6	2,5	2	3	2,5
C	2,1	2,6	3	3,8	4	4,6	5	6
D1	M4	M5	M6	M6	M8	M8	M10	M10
D2	4,3	5,3	6,4	6,4	8,4	8,4	10,5	10,5
T1	6	8	10	12	14	16	18	18
T2	1	1,2	1,2	1,2	1,2	1,5	1,6	1,5
L \ D	6	8	10	12	14	16	18	20
16								
20								
24								
28								
30								
32								
36								
40								
45								
50								
55								
60								
70								
80								
90								
100								
110								
120								
140								

GOUPILLE CYLINDRIQUE NITROCARB® A TROU TARAUDE

NITROCARB® EXTRACTABLE DOWEL PIN  
 NITROCARB® ZYLINDERSTIFT MIT INNENGEWINDE

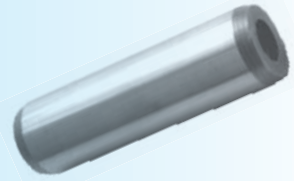

NF EN 28735, ISO 8735

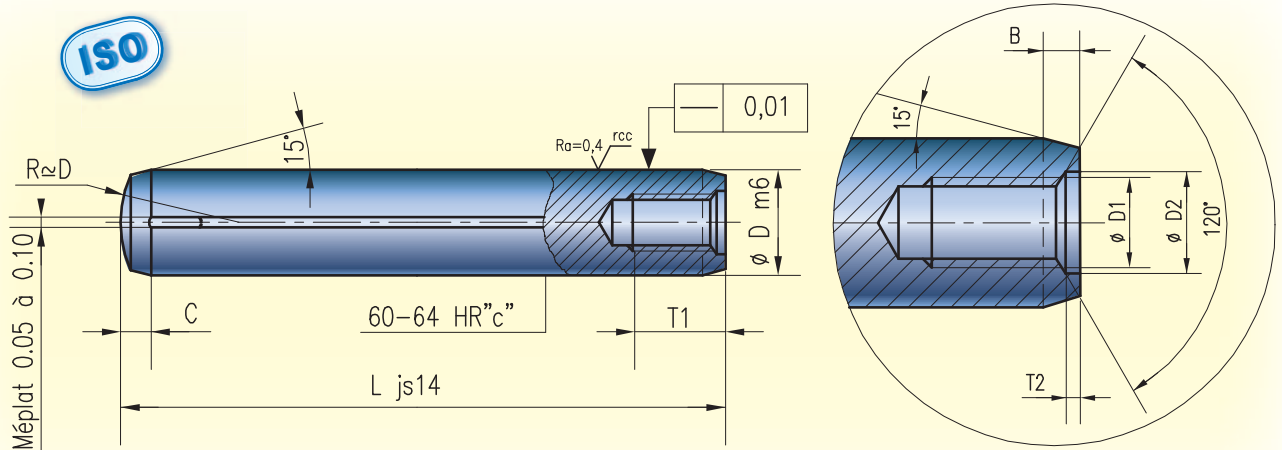

REF. 3122 D=10 L=30 mm



3122-10-30 ( Fabrications spéciales sur demande )

B max	0,8	1	1,2	1,6	2,5	2	3	2,5
C	2,1	2,6	3	3,8	4	4,6	5	6
D1	M4	M5	M6	M6	M8	M8	M10	M10
D2	4,3	5,3	6,4	6,4	8,4	8,4	10,5	10,5
T1	6	8	10	12	12	16	16	18
T2	1	1,2	1,2	1,2	1,2	1,5	1,6	1,5
L \ D	6	8	10	12	14	16	18	20
16								
20								
24								
28								
30								
32								
36								
40								
45								
50								
55								
60								
70								
80								
90								
100								
110								
120								

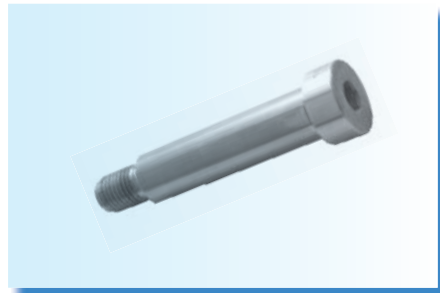

VIS EPAULEE A 6 PANS CREUX

SHOULDER BOLT  
PASSCHRAUBE MIT INNENSECHSKANT

NF E 27-191

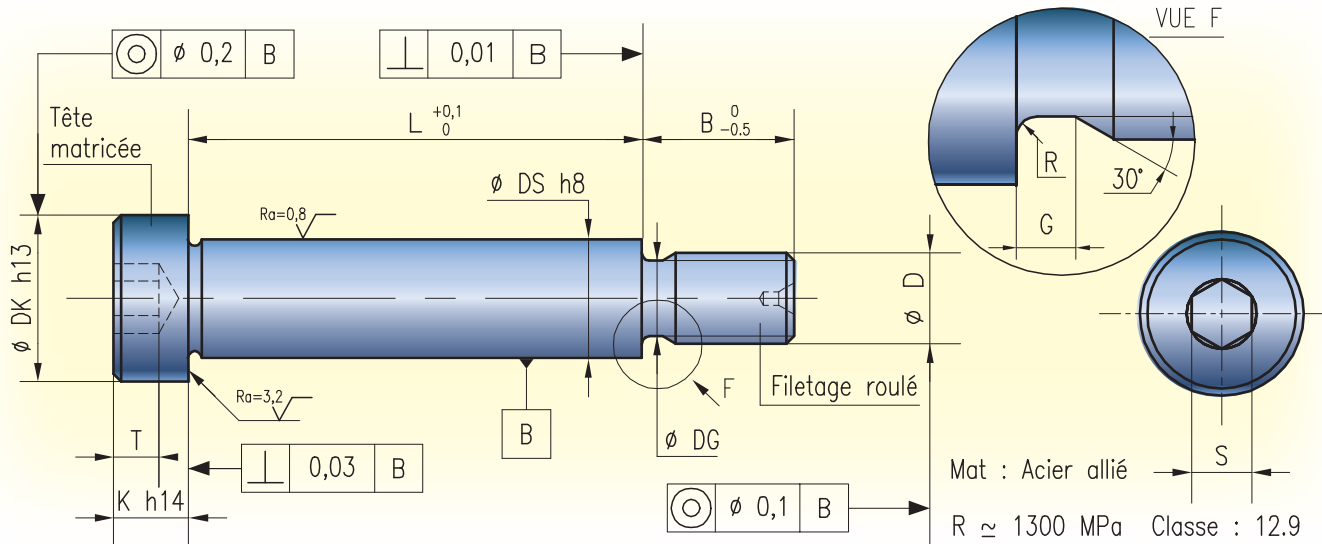

REF. 1021 (ou 3221) D=M8 L=63 mm

1021-8-63 ( Fabrications spéciales sur demande )

Pas ISO	0,8	1	1,25	1,5	1,75	2	2,5	3
DK	9	11	14	18	22	28	36	45
DS	6	8	10	12	16	20	25	32
K	4	5	6	8	10	12	16	20
B	8	10	12	16	20	25	32	40
S	3	4	5	6	8	10	14	17
T	2,5	3	4	5	6	8	11	12
DG	3,9	4,6	6,3	7,9	9,6	13,2	16,5	19,8
G	1,2	1,5	1,9	2,2	2,6	3	3,7	4,5
R	0,4	0,5	0,6	0,8	0,9	1	1,2	1,5
Cs en m.N	6,9	12,8	29,9	58,8	108	264,6	507,5	1000

L \ D	D								
	M5	M6	M8	M10	M12	M16	M20	M24	
6									
8									
10									
12									
14									
16									
20									
25									
30									
32									
40									
50									
60									
63									
70									
80									
90									
100									
110									
120									
125									
140									
160									
200									
250									

VIS EPAULEE A 6 PANS CREUX INOX 17% CR

SHOULDER BOLT STAINLESS STEEL CR 17%  
PASSCHRAUBE MIT INNENSECHSKANT INOX 17% CR

NF E 27-191

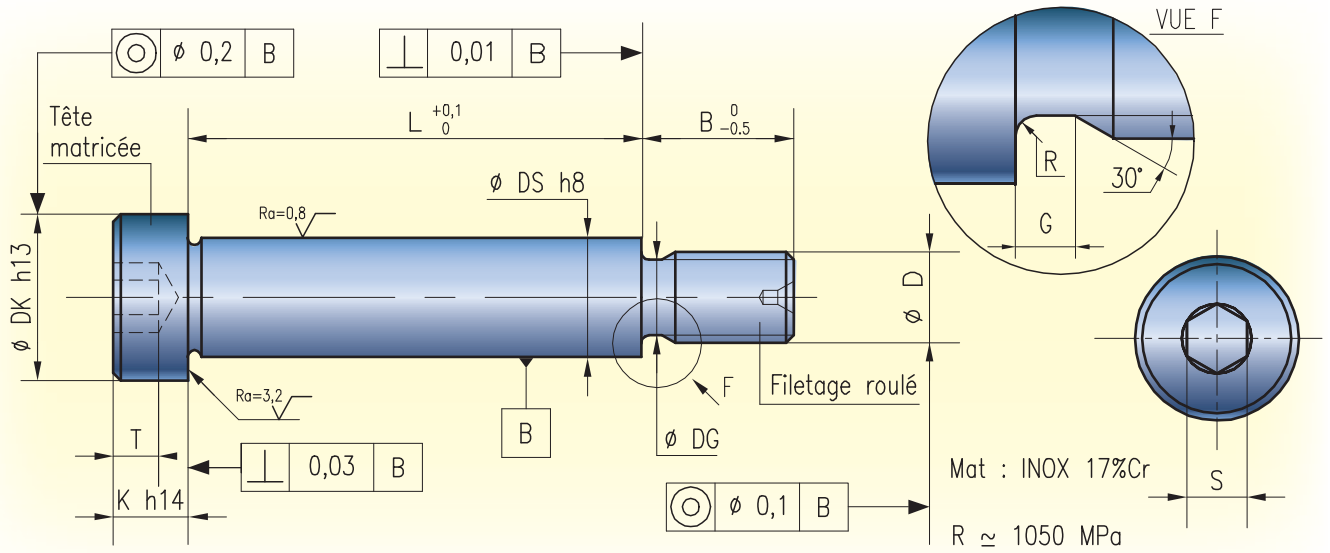
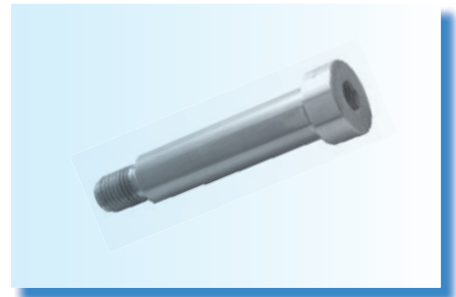

REF. 1031 D=M8 L=60 mm



1031-8-60 ( Fabrications spéciales sur demande )

Pas ISO	0.8	1	1.25	1.5	1.75	2
D K	9	11	14	18	22	28
D S	6	8	10	12	16	20
K	4	5	6	8	10	12
B	8	10	12	16	20	25
S	3	4	5	6	8	10
T	2.5	3	4	5	6	8
D G	3.9	4.6	6.3	7.9	9.6	13.2
G	1.2	1.5	1.9	2.2	2.6	3
R	0.4	0.5	0.6	0.8	0.9	1

L \ D	M5	M6	M8	M10	M12	M16
6						
8						
10						
12						
16						
20						
25						
30						
32						
40						
50						
60						
70						
80						
90						
100						
110						
120						
140						
160						

526



**VIS TETE CYLINDRIQUE BASSE  
A 6 PANS CREUX (CZHC)**

HEXAGON SOCKET HEAD CAP SCREW, SLIM HEAD (CZHC)  
ZYLINDERSCHRAUBE MIT INNENSECHSKANT UND FLACHEM KOPF (CZHC)

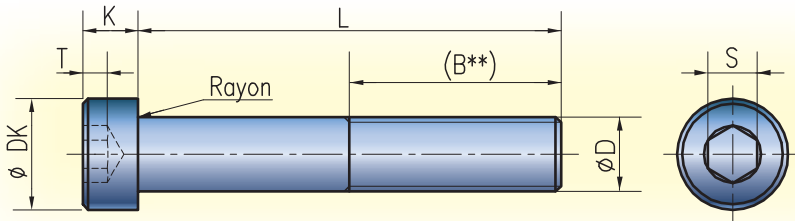

Mat : Acier allié Classe : 10.9 (\*\*B théorique suivant les normes DIN)



REF. 526 D=M8 L=16 mm



526-8-16

B**	(14)	(18)	(22)	(26)
T	2,3	3	3,8	4,5
K	2,8	4	5	6,5
DK	7	10	13	16
S	2,5	4	5	7
Pas iso	0,7	1	1,25	1,5
<b>L \ D</b>	<b>M4</b>	<b>M6</b>	<b>M8</b>	<b>M10</b>
12				
16				
20				
25				
30				

527



**VIS TETE CYLINDRIQUE A 6 PANS CREUX (CHC)**

HEXAGON SOCKET HEAD CAP SCREW (CHC)  
ZYLINDERSCHRAUBE MIT INNENSECHSKANT (CHC)



NF E 25-125, DIN 912

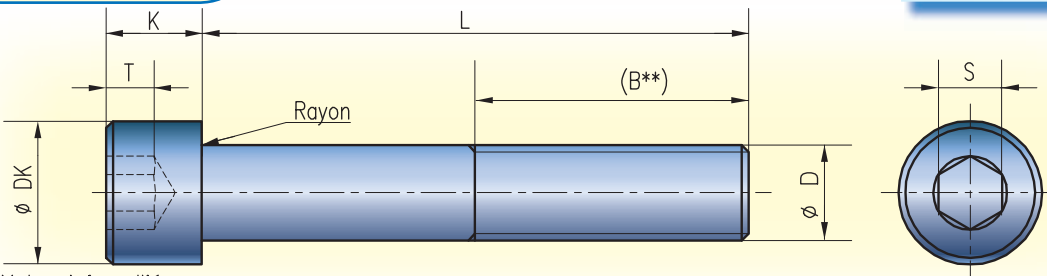

Mat : Acier allié.  
R ≈ 1300 MPa classe : 12.9 (\*\*B théorique suivant la norme DIN 912)



REF. 527 (ou 3211) D=M4 L=6 mm



527-4-6

D	M3	M4	M5	M6	M8	M10	M12	M14	M16	M18	M20	M24	M27	M30
B**	(18)	(20)	(22)	(24)	(28)	(32)	(36)	(40)	(44)	(48)	(52)	(60)	95	95
T	1,3	2	2,5	3	4	5	6	7	8	9	10	12	13,5	15,5
K	3	4	5	6	8	10	12	14	16	18	20	24	27	30
DK	5,5	7	8,5	10	13	16	18	21	24	27	30	36	40	45
S	2,5	3	4	5	6	8	10	12	14	14	17	19	19	22
Pas iso	0,5	0,7	0,8	1	1,25	1,5	1,75	2	2	2,5	2,5	3	3	3,5

# VIS TETE CYLINDRIQUE A 6 PANS CREUX (CHC)

HEXAGON SOCKET HEAD CAP SCREW (CHC)  
 ZYLINDERSCHRAUBE MIT INNENSECHSKANT (CHC)



NF E 25-125, DIN 912

B**	(18)	(20)	(22)	(24)	(28)	(32)	(36)	(40)	(44)	(48)	(52)	(60)	95	95
T	1,3	2	2,5	3	4	5	6	7	8	9	10	12	13,5	15,5
K	3	4	5	6	8	10	12	14	16	18	20	24	27	30
DK	5,5	7	8,5	10	13	16	18	21	24	27	30	36	40	45
S	2,5	3	4	5	6	8	10	12	14	14	17	19	19	22
Pas iso	0,5	0,7	0,8	1	1,25	1,5	1,75	2	2	2,5	2,5	3	3	3,5
L \ D	M3	M4	M5	M6	M8	M10	M12	M14	M16	M18	M20	M24	M27	M30
6														
8														
10														
12														
14														
16														
18														
20														
22														
25														
30														
35														
40														
45														
50														
55														
60														
65														
70														
75														
80														
90														
100														
110														
120														
130														
140														
150														
160														
180														
200														
220														
240														
300														
350														
400														
450														
500														

en dessous du trait  
**B=95**

# VIS TETE CYLINDRIQUE A 6 PANS CREUX NON FILETEE

HEXAGON SOCKET HEAD CAP SCREW BLANK  
ZYLINDERSCHRAUBE MIT INNENSECHSKANT, ROHLING

NF E 25-125, DIN 912

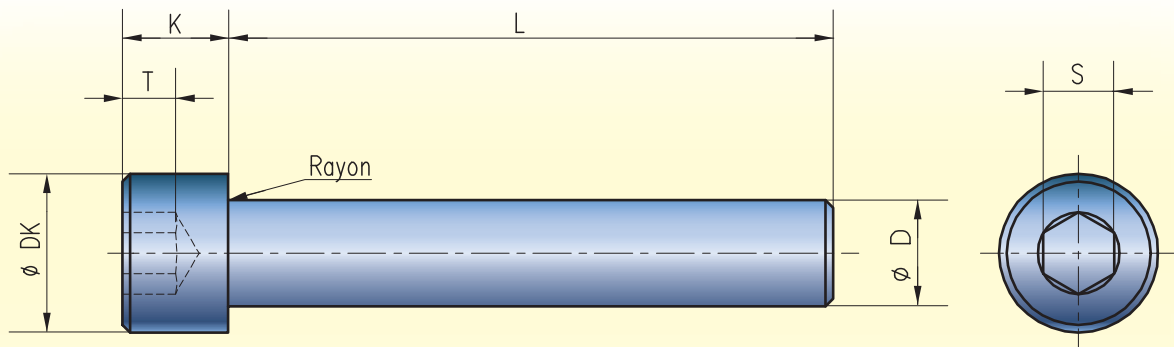
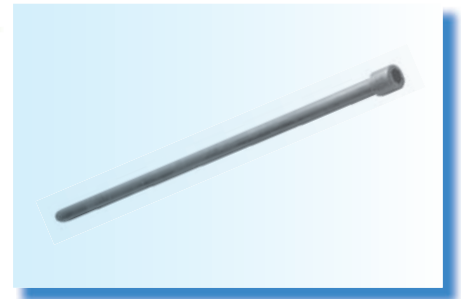

Mat : Acier allié.

R  $\approx$  1300 MPa classe : 12.9



REF. 528 D=18 L=300 mm



528-18-300

K	3	4	5	6	8	10	12	14	16	18	20	24	27	30
T	1,3	2	2,5	3	4	5	6	7	8	9	10	12	13,5	15,5
DK	5,5	7	8,5	10	13	16	18	21	24	27	30	36	40	45
S	2,5	3	4	5	6	8	10	12	14	14	17	19	19	22
L \ D	3	4	5	6	8	10	12	14	16	18	20	24	27	30
100														
150														
200														
250														
300														
400														
500														

### VIS TETE FRAISEE A 6 PANS CREUX

HEXAGON SOCKET COUNTERSUNK HEAD CAP SCREW  
SENKSCHRAUBE MIT INNENSECHSKANT

DIN 7991

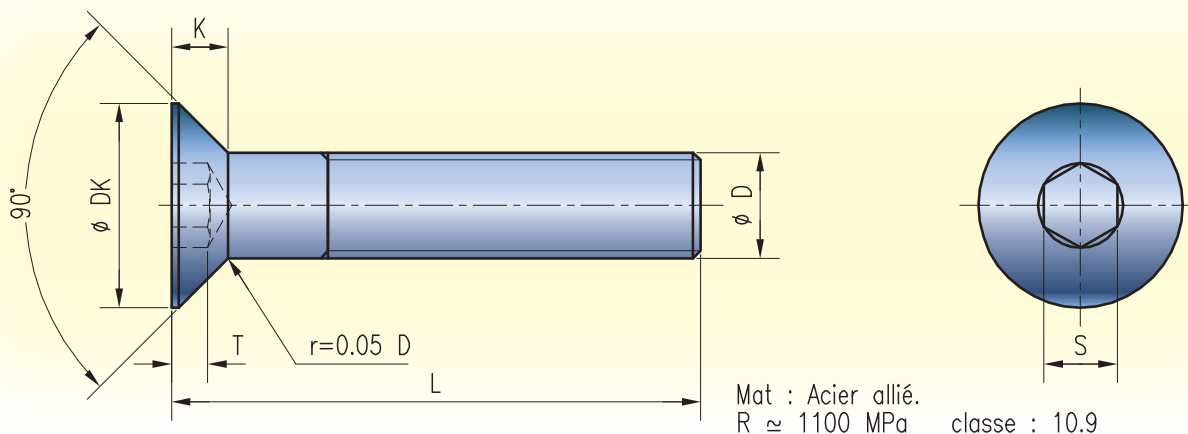

Mat : Acier alli.  
R ≈ 1100 MPa classe : 10.9

REF. 530 (ou 3231) D=M4 L=25 mm



530-4-25 ( Fabrications spéciales sur demande )

T	1,3	2	2,4	2,8	3,8	4,8	5	5,3	5,8	6,5
K	1,7	2,3	2,8	3,3	4,4	5,5	6,5	7	7,5	8,5
DK	6	8	10	12	16	20	24	27	30	36
S	2	2,5	3	4	5	6	8	10	10	12
Pas iso	0,5	0,7	0,8	1	1,25	1,5	1,75	2	2	2,5
<b>L \ D</b>	<b>M3</b>	<b>M4</b>	<b>M5</b>	<b>M6</b>	<b>M8</b>	<b>M10</b>	<b>M12</b>	<b>M14</b>	<b>M16</b>	<b>M20</b>
8										
10										
12										
16										
20										
25										
30										
35										
40										
45										
50										
55										
60										
70										

532



VIS A BILLE A TETE FENDUE

SPRING PLUNGER, SLOTTED  
FEDERNDEN DRUCKSTÜCK MIT SCHLITZ

NFE 63-141

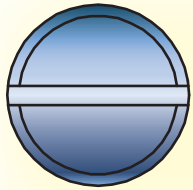
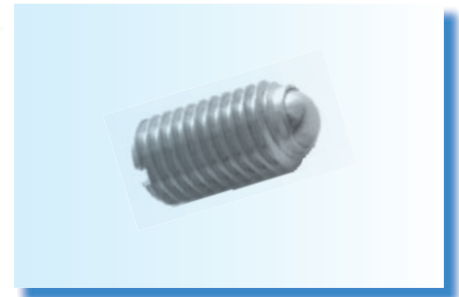

Mat : Acier inox  
T maxi=250°C

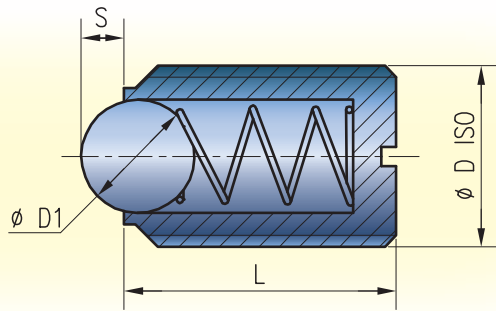

REF. 532 D=M8

532-8

Force en N	Début	2	4	6	9	18	20	30	65	90
	Fin	3	10	11	15	30	40	55	120	140
D1 bille		1,5	2,5	3	3,5	5	6	8	10	12
S		0,5	0,8	0,9	1	1,5	2	2,5	3,5	4,5
L		7	9	12	14	16	19	22	24	30
D		M3	M4	M5	M6	M8	M10	M12	M16	M20
REF. 532										

533



VIS A BILLE SIX PANS CREUX

SPRING PLUNGER, HEXAGON SOCKET  
FEDERNDEN DRUCKSTÜCK MIT INNENSECHSKANT

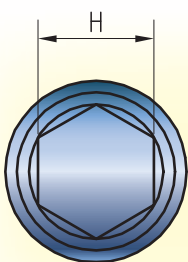

Mat : Acier inox  
T maxi=250°C

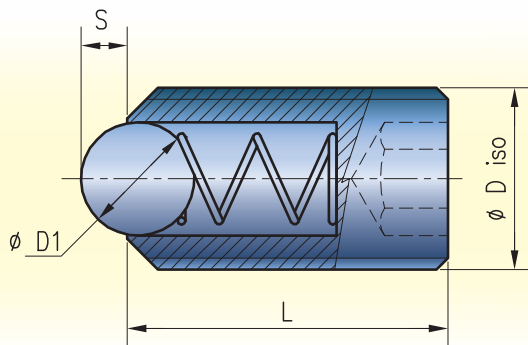

REF. 533 D=M6

533-6

Force en N	Début	11	18	24	26	41	66
	Fin	18	31	45	49	86	111
D1 bille		3,5	4,5	6	8	10	12
S		1	1,5	2	2,5	3,5	4,5
L		15	18	23	26	33	43
H		3	4	5	6	8	10
D		M6	M8	M10	M12	M16	M20
REF. 533							

VIS SANS TETE A 6 PANS CREUX BOUT PLAT

HEXAGON SOCKET SET SCREW WITH FLAT POINT  
 GEWINDESTIFT MIT INNENSECHSKANT

NFE 27-180

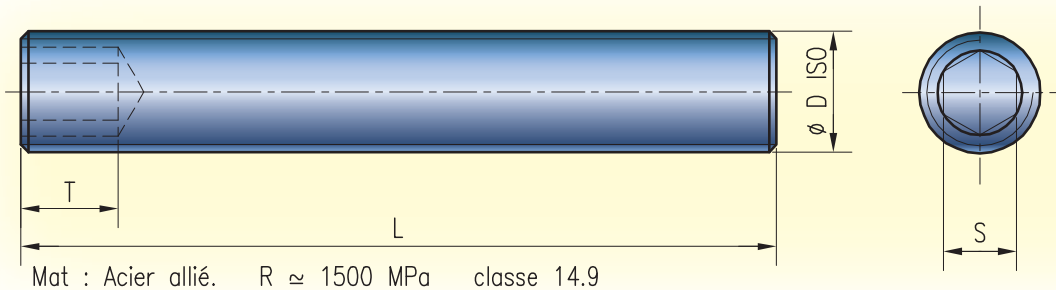

REF. 531 D=M5 L=20 mm



531-5-20 ( Fabrications spéciales sur demande )

\*T dans le cas où L ≤ D

T*	1,2	1,5	2	2	3	4	4,8	4,8	6,4	8
T mini	2	2,5	3	3,5	5	6	8	8	10	12
S	1,5	2	2,5	3	4	5	6	6	8	10
L \ D	M3	M4	M5	M6	M8	M10	M12	M14	M16	M20
5										
6										
8										
10										
12										
16										
20										
25										
30										
35										
40										
45										
50										
60										
70										
80										
90										
100										

VIS SANS TETE A DOUBLE 6 PANS CREUX

HEXAGON SOCKET SET SCREW  
 GEWINDESTIFT MIT INNENSECHSKANT

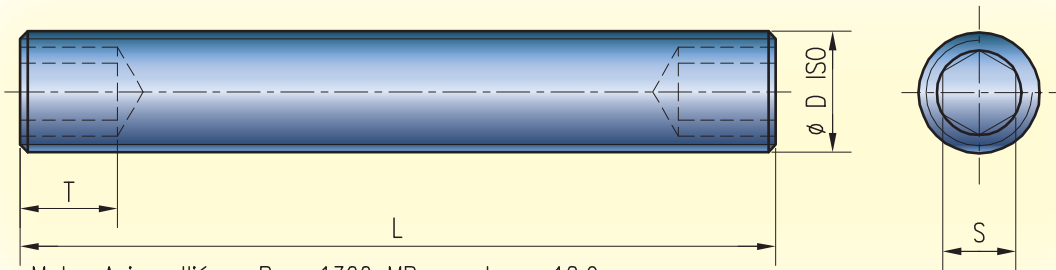

Mat : Acier allié. R ≈ 1300 MPa classe 12.9



REF. 535 D=6 L=30 mm



535-6-30 ( Fabrications spéciales sur demande )

T mini	3,5	5	6	8	10
S	3	4	5	6	8
L \ D	M6	M8	M10	M12	M16
25					
30					
35					
40					
45					
50					
60					
70					
80					



SITE INTERNET RABOURDIN : <http://www.rabourdin.fr>



## TRACE PARTS RABOURDIN

**Bibliothèque de composants standard 2D et 3D 100% intégrée à tous les principaux logiciels de CAO :** SOLIDWORKS, CATIA V5, PRO/ENGINEER, SOLID EDGE, INVENTOR, TOPSOLID, THINKDESIGN, MECHANICAL DESKTOP, UNIGRAPHICS, ACIS, STEP, IGES, PARASOLID, AUTOCAD DWG, DXF.

### Contenu :

Ce CD-Rom inter-actif contient la documentation de Rabourdin Industrie : catalogues 1-50 ; 1-49-1 ; 1-46-7 ; 3-14 ; 3-10 ; 5-11.

Il permet la consultation, la recherche rapide, la sélection de dimensions et les différents paramètres optionnels du composant.

Vous pouvez également consulter les documents « PDF » associés et imprimer toutes les pages des catalogues à partir de votre ordinateur.

**Puissance :** vous disposez de plusieurs moteurs de recherche et d'un viewer 3D dynamique pour accéder rapidement aux données.

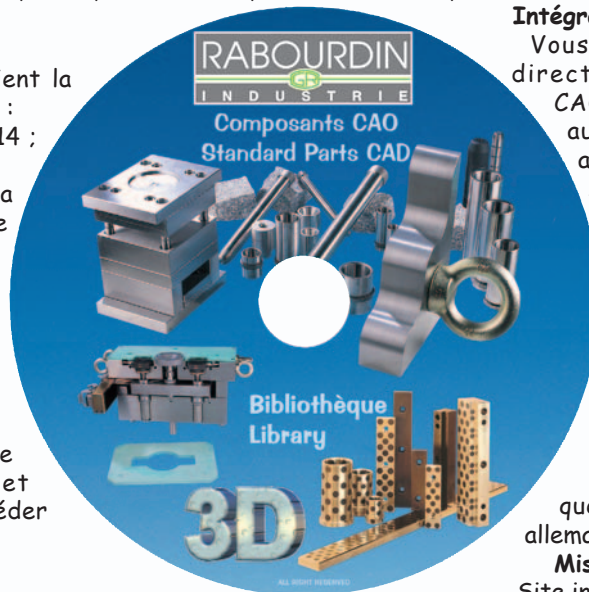

### Intégration :

Vous activez Trace Parts Rabourdin directement depuis votre logiciel de CAO et le composant sélectionné est automatiquement inséré dans votre assemblage en cours, avec toutes ses informations de nomenclature (désignation, référence, fabricant, norme, ...);

**Vues 2D :** une fois le composant sélectionné, vous pouvez générer automatiquement toutes les vues 2D au format DWG ou DXF ;

**Multilingue :** vous pouvez changer de langue de travail en quelques secondes (français, anglais, allemand, espagnol, italien) ;

**Mises à jour :**  
Site internet [www.rabourdin.fr](http://www.rabourdin.fr)

L'accès rapide aux composants normalisés RABOURDIN et leur insertion facile permettent au dessinateur de se consacrer pleinement à la conception mécanique, tout en augmentant de façon considérable la productivité du Bureau d'Etudes.

### Rabourdin Online:

GRATUIT ! Inscrivez-vous dès maintenant...

Créez votre compte personnel sur le site [www.rabourdin.fr](http://www.rabourdin.fr)

Une fois enregistré, vous accédez gratuitement et rapidement aux composants mécaniques normalisés de Rabourdin Industrie dont vous avez besoin. Le contenu de votre panier vous est alors envoyé par E-mail en quelques secondes.



- Éléments standard pour moules: éjecteurs, éléments de guidage, ressorts, cartouches chauffantes, visserie et accessoires divers.
- Composants de construction mécanique.
- Vis spéciales et visserie aéronautique.
- Pièces de micromécanique.
- Éléments standard pour outils de découpe
- Corps de moules et outillages sur plans
- Systèmes canaux chauds
- Corps de moules standard
- Blocs et plaques usinés
- Micro-blocs
- Plaques isolantes MOULISOL®



#### **Rabourdin Industrie**

Parc Gustave Eiffel  
4-5, avenue Gutenberg - BP 50  
Bussy-Saint-Georges  
77607 Marne-la-Vallée Cedex 3 - France

#### **Accueil – standard - Bussy St Georges**

Tél : +33(0)1 64 76 41 01

Fax : +33(0)1 64 76 41 02

E-mail : [industrie@rabourdin.fr](mailto:industrie@rabourdin.fr)

#### **Service télévente : produits standard**

Tél : +33(0)1 64 76 41 00

Fax : +33(0)1 64 76 41 06

E-mail : [televente@rabourdin.fr](mailto:televente@rabourdin.fr)

#### **Service plaques usinées et corps de moule**

Tél : +33(0)3 44 27 03 40

Fax : +33(0)3 44 27 03 42

E-mail : [plaqueoxa@rabourdin.fr](mailto:plaqueoxa@rabourdin.fr)

#### **Service canaux chauds**

Tél : +33(0)1 64 76 41 36

Fax : +33(0)1 64 76 41 02

E-mail : [canauxchauds@rabourdin.fr](mailto:canauxchauds@rabourdin.fr)

#### **Service devis hors standard – vis spéciales**

Tél : +33(0)1 64 76 41 21

Fax : +33(0)1 64 76 41 02

E-mail : [devishstd@rabourdin.fr](mailto:devishstd@rabourdin.fr)

#### **Service découpe – service technique**

Tél : +33(0)1 64 76 41 50

Fax : +33(0)1 64 76 41 02

E-mail : [decoupe@rabourdin.fr](mailto:decoupe@rabourdin.fr)